



NICO RESOURCES

ACN 649 817 425

REPLACEMENT

Prospectus

INITIAL PUBLIC OFFER

For personal use only

PUBLIC OFFER

For an initial public offer of 50,000,000 Shares at a price of \$0.20 per Share to raise a minimum of \$10,000,000 (**Public Offer**). At the discretion of the Directors the Company may accept applications for over-subscriptions to the Public Offer for up to 10,000,000 Shares to raise up to \$2,000,000, with a maximum of \$12,000,000 (before costs) to be raised by the issue of 60,000,000 Shares under the Public Offer.

Metals X Limited has agreed to subscribe for 20,000,000 Shares under the Public Offer.

DISTRIBUTION OFFER

For the distribution in specie by Metals X of 25,000,000 Shares on a pro rata basis to Eligible Metals X Shareholders (**Distribution Offer**). The Distribution Offer is subject to Metals X obtaining Metals X Shareholders' approval of the Distribution at the Metals X General Meeting.

OFFERS CONDITIONAL

The Public Offer and the Distribution Offer (together, the **Offers**) pursuant to this Prospectus are subject to a number of conditions precedent as outlined in Section 2.3 of this Prospectus.

CLOSE OF PUBLIC OFFER

It is proposed that the Public Offer will close at 5.00pm (WST) on 17 December 2021. The Directors reserve the right to close the Public Offer earlier or to extend the closing dates without notice. Applications must be received before that time.

PROPOSED ASX CODE: NCI

IMPORTANT INFORMATION

This is an important document and requires your immediate attention. It should be read in its entirety. Please consult your professional adviser(s) if you have any questions about this document.

Investment in the Securities offered pursuant to this Prospectus should be regarded as speculative in nature, and investors should be aware that they may lose some or all of their investment. Refer to Section 4 for a summary of the key risks associated with an investment in the Securities.

LEAD MANAGERS



AFSL 412765



Marketech Online Trading Pty Ltd
Authorised representative of
Sanlam Private Wealth Pty Ltd
CAR#: 001293528

Corporate Directory

DIRECTORS

Mr Rod Corps	Managing Director
Mr Warren Hallam	Non-Executive Chairman
Mr Brett Smith	Non-Executive Director

COMPANY SECRETARY

Ms Amanda Burgess

REGISTERED AND PRINCIPAL OFFICE

Level 11, 216 St Georges Terrace
PERTH WA 6000

Phone: +61 8 9481 0389

Email: info@nicoresources.com.au

Website: www.nicoresources.com.au

PROPOSED SECURITIES EXCHANGE LISTING

Australian Securities Exchange (ASX)

Proposed ASX Code: NC1

SHARE REGISTRY*

Computershare Investor Services Pty Limited

Level 11, 172 St Georges Terrace
PERTH WA 6000

AUDITOR*

Criterion Audit Pty Ltd

Suite 2, 642 Newcastle Street
LEEDERVILLE WA 6007

SOLICITORS

Blackwall Legal LLP

Level 26, 140 St Georges Terrace
PERTH WA 6000

INDEPENDENT GEOLOGIST

CSA Global Pty Ltd

Level 2, 3 Ord Street
WEST PERTH WA 6005

INVESTIGATING ACCOUNTANT

Criterion Audit Pty Ltd

Suite 2, 642 Newcastle Street
LEEDERVILLE WA 6007

LEAD MANAGERS

Blue Ocean Equities Pty Ltd

AFSL 412765

Level 29 Aurora Place
88 Phillip Street
SYDNEY NSW 2000

Marketech Online Trading Pty Ltd

Authorised Representative of Sanlam Private Wealth
Pty Ltd CAR#:001293528

Level 5, 197 St Georges Terrace
PERTH WA 6000

* These entities are included for information purposes only. They have not been involved in the preparation of this Prospectus.

Table of Contents

Important Information	ii
Letter from the Chairman	1
Key Offer & Capital Structure Details	2
Indicative Timetable	3
01. Investment Overview	4
02. Details of the Offers	13
03. Company Overview	23
04. Risk Factors	39
05. Financial Information	47
06. Board, Management & Corporate Governance	61
07. Material Contracts	69
08. Additional Information	74
09. Authorisation	85
10. Glossary of Terms	86
Schedule 1 – Investigating Accountant’s Report	92
Schedule 2 – Solicitors’ Report	97
Schedule 3 – Independent Technical Assessment Report	142

Important Information

PROSPECTUS

This Prospectus is dated, and was lodged with ASIC on, 23 November 2021. Neither ASIC nor ASX (or their respective officers) take any responsibility for the contents of this Prospectus or the merits of the investment to which this Prospectus relates. The expiry date of this Prospectus is 5.00pm WST on that date which is 13 months after the date this Prospectus was lodged with ASIC. No Securities will be issued on the basis of this Prospectus after that expiry date.

Application will be made to ASX within 7 days of the Prospectus Date for Official Quotation of the Shares the subject of the Offers.

No person is authorised to give any information or to make any representation in connection with the Offers, other than as is contained in this Prospectus. Any information or representation not contained in this Prospectus should not be relied on as having been made or authorised by the Company or the Directors in connection with the Offers.

It is important that you read this Prospectus in its entirety and seek professional advice where necessary. The Securities the subject of this Prospectus should be considered highly speculative.

REPLACEMENT PROSPECTUS

This document is a replacement prospectus which replaces the Company's prospectus dated and lodged with ASIC on 12 November 2021 (Original Prospectus). This document is referred to as either the "Replacement Prospectus" or "Prospectus".

The material differences between the Original Prospectus and this Prospectus are as follows:

- Section 1 of this Prospectus includes further information about the Mineral Resources and Ore Reserves in respect of the CMP Project declared in 2016 and the Phase 1 Feasibility Study (PIFS) completed in 2008 – refer Section 1 'What are the Company's projects'.
- Section 3.4.5 includes additional information about the review of the PIFS by the Independent Geologist.
- The Independent Technical Assessment Report contained in Schedule 3 of the Prospectus contains additional information about the opinion of the Independent Geologist in respect of the Ore Reserves declared in 2016 and the PIFS completed in 2008 – refer to the Executive Summary and section 7.2.4 of the Independent Technical Assessment Report.

- References to the name of a Lead Manager, Marketech Online Trading Pty Ltd, have been corrected.
- Section 6.1 includes additional information about the independence of the Directors.

The amendments made by this Replacement Prospectus are not considered materially adverse to investors.

EXPOSURE PERIOD

The Original Prospectus was subject to an exposure of 7 days from the date of lodgement of the Original Prospectus with ASIC pursuant to the Corporations Act (Exposure Period). The purpose of the Exposure Period was to enable this Prospectus to be examined by market participants prior to the raising of funds.

The Original Prospectus was made available online at the Company's website at www.nicoresources.com.au and in hard copy during the Exposure Period.

CONDITIONAL OFFERS

The Offers contained in this Prospectus are conditional on certain events occurring. If these events do not occur, the Offers will not proceed and investors will be refunded their Application Monies without interest. Please refer to Section 2.3 for further details on the condition attaching to the Offers.

ELECTRONIC PROSPECTUS AND APPLICATION FORM

This Prospectus will generally be made available in electronic form by being posted on the Company's website at www.nicoresources.com.au. Persons having received a copy of this Prospectus in its electronic form may obtain an additional paper copy of this Prospectus and the relevant Application Form (free of charge) from the Company's registered office by contacting the Company as detailed in the Corporate Directory. The Offers constituted by this Prospectus in electronic form is only available to persons receiving an electronic version of this Prospectus and the relevant Application Form within Australia.

Applications will only be accepted on the relevant Application Form attached to, or accompanying, this Prospectus. The Corporations Act prohibits any person from passing on to another person any Application Form unless it is accompanied by or attached to a complete and unaltered copy of this Prospectus.

Prospective investors wishing to subscribe for Shares under the Public Offer should complete an Application Form. If you do not provide the information required on the relevant Application Form, the Company may not be able to accept or process your Application.

No document or information included on the Company's website is incorporated by reference into this Prospectus.

JURISDICTIONAL RESTRICTIONS

This Prospectus does not constitute an offer or invitation in any place in which, or to any person to whom, it would not be lawful to make such an offer or invitation. No action has been taken to register or qualify the Shares or the Offers, or to otherwise permit a public offering of Shares, in any jurisdiction outside Australia. The distribution of this Prospectus (including in electronic form) outside Australia may be restricted by law and persons who come into possession of this Prospectus outside Australia should seek advice and observe any such restrictions. This Prospectus does not constitute an offer or invitation in any jurisdiction in which, or to any person to whom, it would be unlawful to make such an offer or invitation.

RESIDENTS OF THE UNITED STATES OF AMERICA

Neither this Prospectus nor the Shares offered by it have been, nor will they be, registered under the US Securities Act of 1993 as amended (US Securities Act) and may not be offered, sold or resold:

- in the United States of America or to, or for the account or benefit of US Persons (as defined in Rule 902 under the US Securities Act) except in a transaction exempt from the registration requirements of the US Securities Act and applicable United States state securities laws; and
- outside the United States of America, except to non-US persons in offshore transactions in compliance with Regulation S under the US Securities Act.

RESIDENTS OF PEOPLES REPUBLIC OF CHINA

This document has not been approved by, nor registered with, any competent regulatory authority of the People's Republic of China (excluding, for purposes of this paragraph, Hong Kong Special Administrative Region, Macau Special Administrative Region and Taiwan). Accordingly, Securities may not be offered or sold, nor may any invitation, advertisement or solicitation for Securities be made from, within the PRC. This document does not constitute an offer of Securities within the PRC.

The Securities offered by this Prospectus may not be offered or sold to legal or natural persons in the PRC other than to: (i) "qualified domestic institutional investors" as approved by a relevant PRC regulatory authority to invest in overseas capital markets; (ii) sovereign wealth funds or quasi-government investment funds that have the authorization to make overseas investments; or (iii) other types of qualified investors that have obtained all necessary PRC governmental approvals, registrations and/or filings (whether statutorily or otherwise).

RESIDENTS OF HONG KONG

WARNING: This document has not been, and will not be, registered as a prospectus under the Companies (Winding Up and Miscellaneous Provisions) Ordinance (Cap. 32) of Hong Kong, nor has it been authorised by the Securities and Futures Commission in Hong Kong pursuant to the Securities and Futures Ordinance (Cap. 571) of the Laws of Hong Kong (the "SFO"). No action has been taken in Hong Kong to authorise or register this document or to permit the distribution of this document or any documents issued in connection with it. Accordingly, the Securities offered by this Prospectus have not been and will not be offered or sold in Hong Kong other than to "professional investors" (as defined in the SFO and any rules made under that ordinance).

No advertisement, invitation or document relating to the Securities offered by this Prospectus has been or will be issued, or has been or will be in the possession of any person for the purpose of issue, in Hong Kong or elsewhere that is directed at, or the contents of which are likely to be accessed or read by, the public of Hong Kong (except if permitted to do so under the securities laws of Hong Kong) other than with respect to Securities offered by this Prospectus that are or are intended to be disposed of only to persons outside Hong Kong or only to professional investors. No person allotted Securities offered by this Prospectus may sell, or offer to sell, such securities in circumstances that amount to an offer to the public in Hong Kong within six months following the date of issue of such securities.

The contents of this document have not been reviewed by any Hong Kong regulatory authority. You are advised to exercise caution in relation to the offer. If you are in doubt about any contents of this document, you should obtain independent professional advice.

RESIDENTS OF NEW ZEALAND

This document has not been registered, filed with or approved by any New Zealand regulatory authority under the Financial Markets Conduct Act 2013 (the "FMC Act"). The Securities offered by this Prospectus are not being offered or sold in New Zealand (or allotted with a view to being offered for sale in New Zealand) other than to a person who:

- is an investment business within the meaning of clause 37 of Schedule 1 of the FMC Act;
- meets the investment activity criteria specified in clause 38 of Schedule 1 of the FMC Act;
- is large within the meaning of clause 39 of Schedule 1 of the FMC Act;
- is a government agency within the meaning of clause 40 of Schedule 1 of the FMC Act; or
- is an eligible investor within the meaning of clause 41 of Schedule 1 of the FMC Act.

RESIDENTS OF THE UNITED KINGDOM

Neither this document nor any other document relating to the offer has been delivered for approval to the Financial Conduct Authority in the United Kingdom and no prospectus (within the meaning of section 85 of the Financial Services and Markets Act 2000, as amended ("FSMA")) has been published or is intended to be published in respect of the Securities offered by this Prospectus.

The Securities offered by this Prospectus may not be offered or sold in the United Kingdom by means of this document or any other document, except in circumstances that do not require the publication of a prospectus under section 86(1) of the FSMA.

This document is issued on a confidential basis in the United Kingdom to "qualified investors" within the meaning of Article 2(e) of the UK Prospectus Regulation. This document may not be distributed or reproduced, in whole or in part, nor may its contents be disclosed by recipients, to any other person in the United Kingdom.

Any invitation or inducement to engage in investment activity (within the meaning of section 21 of the FSMA) received in connection with the issue or sale of the Securities offered by this Prospectus has only been communicated or caused to be communicated and will only be communicated or caused to be communicated in the United Kingdom in circumstances in which section 21(1) of the FSMA does not apply to the Company.

In the United Kingdom, this document is being distributed only to, and is directed at, persons (i) who have professional experience in matters relating to investments falling within Article 19(5) (investment professionals) of the Financial Services and Markets Act 2000 (Financial Promotions) Order 2005 ("FPO"), (ii) who fall within the categories of persons referred to in Article 49(2)(a) to (d) (high net worth companies, unincorporated associations, etc.) of the FPO or (iii) to whom it may otherwise be lawfully communicated (together "relevant persons"). The investment to which this document relates is available only to relevant persons. Any person who is not a relevant person should not act or rely on this document.

SPECULATIVE INVESTMENT

The Securities offered pursuant to this Prospectus should be considered highly speculative. There is no guarantee that the Securities offered pursuant to this Prospectus will make a return on the capital invested, that dividends will be paid on the Shares or that there will be an increase in the value of the Securities in the future.

Prospective investors should carefully consider whether the Securities offered pursuant to this Prospectus are an appropriate investment for them in light of their

personal circumstances, including their financial and taxation position. Refer to Section 4 for details relating to the key risks applicable to an investment in the Securities.

USING THIS PROSPECTUS

Persons wishing to subscribe for Securities offered by this Prospectus should read this Prospectus in its entirety in order to make an informed assessment of the assets and liabilities, financial position and performance, profits and losses, and prospects of the Company and the rights and liabilities attaching to the Securities offered pursuant to this Prospectus.

If persons considering subscribing for Securities offered pursuant to this Prospectus have any questions, they should consult their stockbroker, solicitor, accountant or other professional adviser for advice.

NO COOLING-OFF RIGHTS

Cooling-off rights do not apply to an investment in Securities issued under this Prospectus. This means that, in most circumstances, you cannot withdraw your Application once it has been accepted.

FORWARD-LOOKING STATEMENTS

This Prospectus contains forward-looking statements which are identified by words such as "believes", "estimates", "expects", "targets", "intends", "may", "will", "would", "could", or "should" and other similar words that involve risks and uncertainties.

These statements are based on an assessment of present economic and operating conditions, and on a number of assumptions regarding future events and actions that, as at the Prospectus Date, are considered reasonable.

Such forward-looking statements are not guarantees of future performance and involve known and unknown risks, uncertainties, assumptions and other important factors, many of which are beyond the control of the Company, the Directors of the Company. Key risk factors associated with an investment in the Company are detailed in Section 4. These and other factors could cause actual results to differ materially from those expressed in any forward-looking statements.

The Company has no intention to update or revise forward-looking statements, or to publish prospective financial information in the future, regardless of whether new information, future events or any other factors affect the information contained in this Prospectus, except where required by law.

The Company cannot and does not give assurances that the results, performance or achievements expressed or implied in the forward-looking statements contained in this Prospectus will actually occur and investors are cautioned not to place undue reliance on these forward-looking statements.

EXPLORATION RESULTS, EXPLORATION TARGETS, MINERAL RESOURCES AND ORE RESERVES

Exploration Results, Exploration Targets, Mineral Resources and Ore Reserve estimates contained in this Prospectus are stated in accordance with the JORC Code and are expressions of judgment based on knowledge, experience and industry practice. Although Exploration Results, Exploration Targets, Mineral Resources and Ore Reserve estimates contained in this Prospectus comply with the JORC Code, they may not comply with the relevant guidelines in other countries.

COMPETENT PERSONS STATEMENTS

The information in this Prospectus that relates to Exploration Results and Mineral Resources for the CMP Project is based on information reviewed by Mr Jake (Jacob) Russell from Metals X, who was previously an employee of Metals X, and is a member of the AIG, and has sufficient experience, which is relevant to the style of mineralisation and type of deposit under consideration, and to the activity he is undertaking, to qualify as a Competent Person in terms of the JORC Code.

The Exploration Results and Mineral Resources information in this Prospectus has been reviewed by Mr Tony Donaghy who is a Principal Consultant and Technical Director Nickel with CSA Global Pty Ltd. Mr Donaghy takes overall responsibility for this information as a Competent Person. Mr Donaghy is a Registered Professional Geoscientist with the Association of Professional Geoscientists of Ontario and has sufficient experience that is relevant to the technical assessment of the mineral assets under consideration, the style of mineralisation and types of deposit under consideration and to the activity being undertaken to qualify as a Competent Person under the JORC Code. The Competent Person, Mr Donaghy has reviewed the Exploration Results and Mineral Resources statements in this Prospectus and given permission for the publication of this information in the form and context within which it appears in this Prospectus.

The information in this Prospectus that relates to Ore Reserves is based on information compiled by Mr Michael Poepjes, who was a previous employee of Metals X in 2016, and a Member of the AusIMM at the time. This information has been reviewed by Mr Mark Laing, an employee of CSA Global Pty Ltd. Mr Laing is a Member of the AusIMM and has sufficient experience, which is relevant to the style of mineralisation and type of deposit under consideration, and to the activity he is undertaking, to qualify as a Competent Person in terms of the JORC Code. Mr Laing has reviewed the Ore Reserve statement in this Prospectus and given permission for the publication of this information in the form and context within which it appears in this Prospectus.

PRACTITIONER CONSENT – INDEPENDENT GEOLOGIST

CSA Global Pty Ltd has given its written consent to being named as Independent Geologist in this Prospectus, the inclusion of the Independent Technical Assessment Report in Appendix 1 of this Prospectus in the form and context in which the report is included and the inclusion of statements contained in Appendix 1 of this Prospectus in the form and context in which those statements are included. CSA Global Pty Ltd has not withdrawn its consent prior to lodgement of this Prospectus with ASIC.

PHOTOGRAPHS AND DIAGRAMS

Photographs used in this Prospectus which do not have descriptions are for illustration only and should not be interpreted to mean that any person shown endorses this Prospectus or its contents or that the assets shown in them are owned by the Company. Diagrams used in this Prospectus are illustrative only and may not be drawn to scale. Unless otherwise stated, all data contained in charts, graphs and tables is based on information available at the Prospectus Date.

MISCELLANEOUS

All financial amounts contained in this Prospectus are expressed as Australian currency unless otherwise stated. Conversions may not reconcile due to rounding. All references to “\$” or “A\$” are references to Australian dollars.

All references to time in this Prospectus are references to WST, being the time in Perth, Western Australia, unless otherwise stated.

Defined terms and abbreviations used in this Prospectus are detailed in the glossary in Section 10.

Letter from the Chairman

DEAR INVESTOR

On behalf of my fellow Directors, it is with great pleasure that I present to you this Prospectus and invite you to become a shareholder of NICO Resources Limited (**NICO** or the **Company**).

The Company is a newly incorporated mineral exploration and development company committed to increasing shareholder wealth through the acquisition, exploration and development of mineral resource projects throughout Western Australia and South Australia.

NICO has brought together a team with vast knowledge and experience in exploration, project generation, project development and mining operations. The Company's Board has significant experience, which includes executive and board positions with Metals X Limited, Westgold Resources Limited, Aziana Limited, APAC Resources Limited, Dragon Mining Limited, Millennium Minerals Limited and Ausenco Limited, among others.

The purpose of the Public Offer is to raise a minimum of \$10,000,000 and up to \$12,000,000 (before associated costs) by issuing a minimum of 50,000,000 Shares and up to 60,000,000 Shares at an issue price of \$0.20 each. It presents investors with the opportunity to become a part of a results-focused mineral exploration and development company, where the majority of funds raised are directed towards advancing the Wingellina nickel-cobalt-scandium project towards development.

The proceeds of the Public Offer will be utilised to enable the Company to undertake various exploration programs in order to determine how best to exploit the potential high-grade zones of nickel, cobalt and scandium; review the various mineral processing routes in order to identify any additional metallurgical testwork to maximise the value of extraction of minerals from the Central Musgrave Project; and review all historical data to identify any additional information or programmes required to undertake a comprehensive feasibility study update, including the exploitation of the resources, infrastructure requirements, approvals and sources for calccrete and water.

The Central Musgrave Project is located within South Australia and Western Australia, adjacent and south of the Surveyor Generals corner of South Australia, Western Australia and Northern Territory.

Detailed information about the Project is set out in the Independent Technical Assessment Report in Schedule 3 to this Prospectus.

This Prospectus also contains detailed information about the Offers and the current and proposed operations of the Company, as well as the risks pertaining to an investment in the Company which are contained in Section 4. Potential investors in the Company should carefully consider those risks before making an investment decision and, if required, consult with a stockbroker, solicitor, accountant or other independent professional adviser.

We look forward to welcoming you as a Shareholder should you decide to take up Shares pursuant to the Public Offer or should you receive Shares under the Distribution Offer.

Yours faithfully



Warren Hallam

Non-Executive Chairman

Key Offer & Capital Structure Details

Pro forma capital structure ¹	Shares	Options
Securities currently on issue ²	6,000,002	34,000,000 ³
Shares to be issued to Metals X under the Acquisition (and distributed under the Distribution Offer)	25,000,000 ⁴	
Shares offered under the Public Offer for \$0.20 each:		
Minimum Subscription (raising \$10.0m (before costs))	50,000,000	-
Maximum Subscription (raising \$12.0m (before costs))	60,000,000	-
Lead Manager Options ⁵ to be issued to Blue Ocean Equities	-	800,000
Total Securities on issue on completion of the Offers⁶		
Minimum Subscription	81,000,002	34,800,000
Maximum Subscription	91,000,002	34,800,000

Notes:

1. Please refer to Section 2.5 for further details relating to the proposed capital structure of the Company.
2. See Section 3.2 for further details of the current capital structure of the Company.
3. Comprising 25,000,000 Metals X Options on the terms and conditions set out in Section 8.2 and 9,000,000 Director Options on the terms and conditions set out in Section 8.3.
4. Shares to be distributed by Metals X to Eligible Metals X Shareholders under the Distribution Offer.
5. Pursuant to the Lead Manager Mandate, the Company has agreed to issue to Blue Ocean Equities (or its nominees) 800,000 Options exercisable at \$0.30 within 3 years of the grant the Options on the terms and conditions set out in Section 8.2.
6. Assuming no further Securities are issued and none of the above Options are exercised.

Indicative Timetable

Event	Date
Lodgement of the Original Prospectus with ASIC	Friday, 12 November 2021
Expiry of Exposure Period	Friday, 19 November 2021
Lodgement of this Replacement Prospectus with ASIC (Prospectus Date)	Tuesday, 23 November 2021
Opening Date for the Public Offer	Wednesday, 24 November 2021
Closing Date for the Public Offer	Friday, 17 December 2021
Issue Date of Shares and despatch of holding statements	Thursday, 23 December 2021
Expected date for Official Quotation of Shares on ASX	Tuesday, 11 January 2022

The dates shown in the table above are indicative only and may vary subject to the Corporations Act, the Listing Rules and other applicable laws. In particular, the Company reserves the right to vary the Opening Date and the Closing Dates without prior notice, which may have a consequential effect on the other dates. Applicants are therefore encouraged to lodge their Application Form and deposit the Application Monies as soon as possible after the Opening Date if they wish to invest in the Company.

01. Investment Overview

This Section is not intended to provide full information for investors intending to apply for Securities offered pursuant to this Prospectus. This Prospectus should be read and considered in its entirety. The Securities offered pursuant to this Prospectus carry no guarantee in respect of return of capital, return on investment, payment of dividends or the future value of the Securities.

Topic	Summary	More information
INTRODUCTION		
<p>Who is the Company and what does it do?</p>	<p>NICO Resources Limited (ACN 649 817 425) (Company) is an Australian company incorporated on 29 April 2021 for the purpose of pursuing various mining opportunities in the resources sector designed to add shareholder value by exploring, developing, evaluating, acquiring, and exploiting mineral resource project opportunities and, other than as disclosed in this Prospectus, has not undertaken any activities since incorporation.</p> <p>Since incorporation, the Company has agreed to acquire a 100% legal and beneficial interest in the nickel assets of Metals X consisting of the Wingellina (WA) and Claude Hills (SA) nickel projects, via the acquisition of 100% of the shares in Metals Exploration from Metals X under the Share Sale Agreement.</p>	<p>Section 3.1</p>
<p>What are the Company's projects?</p>	<p>Central Musgrave Project (CMP)</p> <p>The Central Musgrave Project (CMP) tenements comprise 3 main exploration licences, known as - Wingellina (WA), Claude Hill (SA) and Mt Davies (SA), an exploration licence covering the Lewis calcrete resource and three miscellaneous licences covering the defined water resources.</p> <p>The Tenements host nickel-cobalt-scandium lateritic Mineral Resources in excess of 200 million tonnes, containing 1.95 million tonnes of nickel and 150 thousand tonnes of cobalt, along with a probable Ore Reserve of 164.8 million tonnes containing 1.56 million tonnes of Nickel and 123,000 tonnes of cobalt.</p> <p>Both Mineral Resources and Ore Reserves in respect of the CMP Project were declared in 2016, and were reviewed for this Prospectus.</p>	<p>Section 3.4, the Solicitors' Report in Schedule 2 and the Independent Technical Assessment Report in Schedule 3</p>

Topic	Summary	More information
INTRODUCTION (CONTINUED)		
	<p>The Mineral Resource estimation parameters, methodologies and conclusions have been completed in accordance with good industry practice and the JORC Code. A detailed peer review of the resource model has been recommended to examine all relevant parameters in a proposed update to the Mineral Resource estimate. With expected changes to these parameters and other modifying factors, it is anticipated a new Ore Reserve estimate would need to be declared with the updated pre-feasibility study (PFS).</p> <p>The project tenure is approximately 1,469km² in area and is located within Western Australia and South Australia adjoining the Surveyor Generals Corner (the junction between Western Australia, the Northern Territory and South Australia).</p> <p>A Phase 1 Feasibility Study (+/-25%) envisioning HPAL processing was completed in 2008 which indicated a potential project mine life in excess of 30 years, producing between 30,000 to 39,000 tpa of nickel. This study has been reviewed by the Independent Geologist and the Company has received recommendations to move the CMP Project forward to a pre-feasibility study (PFS) level of confidence in accordance with the JORC and VALMIN reporting standards. The Company aspires to commence the required work to advance the CMP Project to a PFS within the first two years after Admission.</p> <p>The Wingellina deposit hosts measured, indicated and inferred Mineral Resources of 182.6Mt at 0.92% Ni & 0.07% Co for 1.68Mt of contained nickel and 132Kt of contained cobalt, and hosts probable Ore Reserves of 168.4Mt at 0.93% Ni & 0.07% Co for 1.56Mt of contained nickel and 123Kt of contained cobalt.</p> <p>The Claude Hills deposit located less than 20km from Wingellina hosts Inferred Resources of 33.3 Mt at 0.81% Ni and 0.07% Co for 270Kt of contained nickel and 23Kt of contained cobalt.</p> <p>Various metallurgical testwork programs have been undertaken by Metals X providing for the potential commercial production of high-quality cobalt and nickel sulphates, mixed nickel / cobalt sulphides, hydroxides and carbonates, and scandium.</p> <p>Due to the intense oxidation of the ores, mining is anticipated to be low cost as the ores can be extracted without the requirement for blasting. Mining studies, completed as part of the Phase 1 Feasibility Study estimated the average waste:ore strip ratio for the first 20 years of mining being only 0.5:1 and for the 39-year project 1:1.</p> <p>The defined basal contact of the layered intrusion has been defined to extend for over 100km across all of the tenements of the CMP and there are numerous known zones of associated mineralised still to be tested.</p> <p>Following completion of the Offers and the Acquisition, the Company will have a 100% legal and beneficial interest in these projects.</p>	
<p>What is the Company's financial position?</p>	<p>The Company has not traded since incorporation. Therefore, it has not earned any revenue or incurred expenses from its activities, other than the expenses of the Public Offer.</p> <p>An Investigating Accountant's Report is included in Schedule 1 which contains financial information about the Company.</p> <p>The Board is satisfied that upon completion of the Offers, the Company will have adequate working capital to meet its stated objectives.</p>	<p>Section 5 and Schedule 1</p>
<p>What is the proposed capital structure of the Company?</p>	<p>Following completion of the Offers under this Prospectus, the proposed capital structure of the Company will be as set out in Section 2.5.</p>	<p>Section 2.5</p>

Topic	Summary	More information
What is the proposed use of funds raised under the Public Offer?	The Company proposes to use the funds raised from the Public Offer towards exploration on the Tenements, studies and reviews, expenses of the Offers, general administration fees and working capital.	Section 2.4
What is the Company's strategy?	<p>Following Admission, the Company's primary focus will be to:</p> <p>Undertake various exploration programs in order to determine how best to exploit the potential high-grade zones of nickel, cobalt and scandium.</p> <p>Review all of the various mineral processing routes in order to identify any additional metallurgical testwork to maximise the value of extraction of minerals from the Central Musgrave Project.</p> <p>Review all historical data to identify any additional information or programmes required to undertake a comprehensive feasibility study update, including the exploitation of the resources, infrastructure requirements, approvals and sources for calcrete and water.</p>	Section 3.5

SUMMARY OF KEY RISKS

Prospective investors should be aware that subscribing for Shares in the Company involves a number of risks. The risk factors set out in detail in Section 4, and other general risks applicable to all investments in listed securities, may affect the value of the Shares in the future. Accordingly, an investment in the Company should be considered highly speculative. This Section summarises the key risks which apply to an investment in the Company and **investors should refer to Section 4 for a more detailed summary of the risks.**

Limited history	The Company was incorporated on 29 April 2021 and therefore has limited operational and financial history on which to evaluate its business and prospects. The prospects of the Company must be considered in light of the risks, expenses and difficulties frequently encountered by companies in the early stages of their development, particularly in the mineral exploration sector, which has a high level of inherent risk and uncertainty.	Section 4.1(a)
New projects and acquisitions	<p>The Company will actively pursue and assess other new business opportunities in the resources sector. These new business opportunities may take the form of direct project acquisitions, joint ventures, farm-ins, acquisition of tenements/permits, and/or direct equity participation.</p> <p>The acquisition of projects (whether completed or not) may require the payment of monies (as a deposit and/or exclusivity fee). There can be no guarantee that any proposed acquisition will be completed or be successful. Monies payable may not be recoverable, the Company may need to reallocate funds or may need to raise additional capital. In addition the usual risks associated with the new project/business activities will remain.</p>	Section 4.1(b)
Future capital requirements	The Company has no operating revenue and is unlikely to generate any operating revenue in the near term. The future capital requirements of the Company will depend on many factors including its business development activities. In order to successfully develop the Projects and for production to commence, the Company will require further financing in the future. Any additional equity financing may be dilutive to Shareholders and any debt financing may involve restrictions on financing and operating activities.	Section 4.1(c)
Tenement title renewal risk	<p>One the Tenements comprising the Project, E69/535 located in WA, is nearing expiry and one of the Tenements, EL 5860 located in SA, has recently expired. Applications for renewal of these Tenements have been lodged with the relevant authorities, however no outcome has been received as at the Prospectus Date.</p> <p>The deposit hosting most of the Mineral Resources of the Wingellina Project is located within E69/535.</p>	Section 4.1(d) and the Solicitors' Report

Topic	Summary	More information
SUMMARY OF KEY RISKS (CONTINUED)		
	E69/535 is due to expire on 22 December 2021 and is only eligible for renewal each year for a maximum period of 12 months upon application to the Minister under the Mining Act (WA). There is no guarantee that any renewal or extension will be granted this year or any subsequent year, however as the term of E69/535 has been renewed annually for several past years, the Company does not anticipate that E69/535 will not be renewed.	
Exploration and development risks	<p>Mineral exploration and development is a high-risk undertaking. There can be no assurance that exploration of the Projects or any other exploration properties that may be acquired in the future will result in the discovery of an economic resource.</p> <p>Even if an apparently viable resource is identified, there is no guarantee that it can be economically exploited due to various issues including lack of ongoing funding, adverse government policy, geological conditions, commodity prices or other technical difficulties.</p>	Section 4.1(e)
Potential site access restrictions due to COVID-19	<p>travel to and within the CMP region and has been and remains limited in Western Australia under the Emergency Management Act 2005 (WA) - Remote Aboriginal Communities Directions (No. 3) to those providing essential services. Although field personnel can travel to site, they are confined to the exploration camp at Wingellina under COVID-19 isolation protocol requirements.</p> <p>The South Australian Government advised on 10 July 2021 that restrictions would be lifted, however various restrictions into the Anangu Pitjantjatjara Yankunytjatjara (APY) lands (SA Tenements) may remain in place outside of SA Government health and/or emergency directives and access permit procedures remain in place.</p> <p>These restrictions will and may limit the type of exploration activities that can be undertaken and may delay various exploration programs to be undertaken.</p>	Section 4.1(f)
Operating risks	The operations of the Company may be affected by various factors, including failure to locate or identify mineral deposits, failure to achieve predicted grades in exploration and mining, operational and technical difficulties encountered in mining, metallurgy difficulties, commissioning and in operating plant and equipment, mechanical failure or plant breakdown, adverse weather conditions, industrial and environmental accidents, industrial disputes and unexpected shortages or increases in the costs of personnel, consumables, spare parts, plant and equipment.	Section 4.1(g)
Metallurgy risks	Metal and/or mineral recoveries are dependent upon the metallurgical process that is required to liberate economic minerals and produce a saleable product and by its nature contains elements of significant risk	Section 4.1(h)
Metals and currency price volatility	The Company's ability to proceed with the development of its projects and benefit from any future mining operations will depend on market factors, such as commodity prices and exchange rates some of which may be beyond its control.	Section 4.1(i)
Aboriginal heritage risk	<p>A number of Aboriginal heritage sites have been identified on the land the subject of the Tenements. There is a risk that additional Aboriginal sites may exist on the land the subject of the Tenements.</p> <p>The existence of such sites may preclude or limit exploration and mining activities in certain areas of the Tenements.</p>	Section 4.1(j) and the Solicitors' Report
Native Title risk	<p>The Company is aware that there are two registered native titles within the area covered by the Tenements.</p> <p>There remains a risk that in the future, native title and/or registered native title claims may affect the land the subject of the Tenements or in the vicinity.</p>	Section 4.1(k) and the Solicitors' Report

Topic	Summary	More information
SUMMARY OF KEY RISKS (CONTINUED)		
Development and mining on APY lands	<p>The Tenements in South Australia are situated on lands belonging to the Anangu Pitjantjatjara Yankunytjatjara (APY).</p> <p>Access to the APY lands and the conduct of exploration, mining and associated activities on the APY lands is subject to the terms and conditions set out in two separate deeds of exploration entered into with the APY.</p> <p>The conduct of future development and mining operations on the SA Tenements will depend on the Company reaching further agreement with the APY.</p> <p>No assurance can be given that the Company will be able to reach agreement with the APY respect of any development or mining proposal within any particular time frame.</p>	Section 4.1(l) and the Solicitors' Report
Environmental risk	<p>The operations and proposed activities of the Company are subject to state and federal laws and regulations concerning the environment. As with most exploration projects and mining operations, the Company's activities are expected to have an impact on the environment.</p> <p>The cost and complexity of complying with the applicable environmental laws and regulations, the inability to obtain approvals or changes or additions to the laws and regulations may prevent the Company from being able to develop potentially economically viable mineral deposits.</p>	Section 4.1(m)
Metals and currency price volatility	The Company's ability to proceed with the development of its projects and benefit from any future mining operations will depend on market factors, some of which may be beyond its control. It is anticipated that any revenues derived from mining will primarily be derived from the sale of nickel and cobalt. Consequently, any future earnings are likely to be closely related to the price of nickel and cobalt and the terms of any off-take agreements that the Company enters into.	Section 4.1(n)
Infectious diseases	The outbreak of the coronavirus disease COVID-19 is creating uncertainty and having a material effect on global economic markets which may adversely impact the Company's operations.	Section 4.1(o)

DIRECTORS, RELATED PARTY INTEREST AND SUBSTANTIAL HOLDERS

Who are the Directors?	<p>The Directors are:</p> <p>Mr Rod Corps - Executive Director and CEO</p> <p>Mr Warren Hallam - Non-Executive Chairman</p> <p>Mr Brett Smith - Non-Executive Director</p>	"Corporate Directory" and Section 6.1
What benefits are being paid to the Directors?	<p>Mr Rod Corps has entered into an executive services agreement with the Company, pursuant to which he is engaged as the Managing Director and the Chief Executive Officer of the Company and is entitled to receive \$250,000 per annum (plus statutory superannuation entitlements) from 1 September 2021.</p> <p>Mr Warren Hallam has entered into a non-executive director letter of appointment with the Company, pursuant to which Mr Hallam will receive, from 1 September 2021, \$60,000 per annum (plus statutory superannuation entitlements) for services provided to the Company as Non-Executive Chairman.</p> <p>Mr Brett Smith entered into a non-executive director letter of appointment with the Company, pursuant to which Mr Smith will receive, from 1 September 2021, \$40,000 per annum (plus statutory superannuation entitlements) for services provided to the Company as Non-Executive Director.</p> <p>The Directors' have also been issued Director Options (9,000,000 in aggregate) exercisable at \$0.20 each within 3 years from the date of grant and otherwise on the terms and conditions set out in Section 8.3.</p>	Section 6.5

Topic	Summary	More information																																								
DIRECTORS, RELATED PARTY INTEREST AND SUBSTANTIAL HOLDERS (CONTINUED)																																										
What interests do Directors have in the securities of the Company?	<p>The Directors and their related entities hold the following interests in Securities in the Company as at the Prospectus Date:</p> <table border="1"> <thead> <tr> <th>Director</th> <th>Shares</th> <th>%</th> <th>Options</th> <th>%</th> </tr> </thead> <tbody> <tr> <td>Rod Corps</td> <td>1,500,001</td> <td>25%</td> <td>3,000,000</td> <td>8.82%</td> </tr> <tr> <td>Warren Hallam</td> <td>1,750,001</td> <td>29.17%</td> <td>3,000,000</td> <td>8.82%</td> </tr> <tr> <td>Brett Smith</td> <td>Nil</td> <td>-</td> <td>3,000,000</td> <td>8.82%</td> </tr> </tbody> </table> <p>Based on the intentions of the Directors at the Prospectus Date in relation to the Offers, the Directors and their related entities will have the following interests in Securities on Admission (on a Minimum Subscription basis):</p> <table border="1"> <thead> <tr> <th>Director</th> <th>Shares</th> <th>%</th> <th>Options</th> <th>%</th> </tr> </thead> <tbody> <tr> <td>Rod Corps</td> <td>1,500,001</td> <td>1.85%</td> <td>3,000,000</td> <td>8.62%</td> </tr> <tr> <td>Warren Hallam</td> <td>2,026,422</td> <td>2.50%</td> <td>3,000,000</td> <td>8.62%</td> </tr> <tr> <td>Brett Smith</td> <td>5,787</td> <td>0%</td> <td>3,000,000</td> <td>8.62%</td> </tr> </tbody> </table>	Director	Shares	%	Options	%	Rod Corps	1,500,001	25%	3,000,000	8.82%	Warren Hallam	1,750,001	29.17%	3,000,000	8.82%	Brett Smith	Nil	-	3,000,000	8.82%	Director	Shares	%	Options	%	Rod Corps	1,500,001	1.85%	3,000,000	8.62%	Warren Hallam	2,026,422	2.50%	3,000,000	8.62%	Brett Smith	5,787	0%	3,000,000	8.62%	Section 6.4
Director	Shares	%	Options	%																																						
Rod Corps	1,500,001	25%	3,000,000	8.82%																																						
Warren Hallam	1,750,001	29.17%	3,000,000	8.82%																																						
Brett Smith	Nil	-	3,000,000	8.82%																																						
Director	Shares	%	Options	%																																						
Rod Corps	1,500,001	1.85%	3,000,000	8.62%																																						
Warren Hallam	2,026,422	2.50%	3,000,000	8.62%																																						
Brett Smith	5,787	0%	3,000,000	8.62%																																						
What important contracts with related parties is the Company a party to?	<p>The Company has entered into the following related party transactions on arms' length terms:</p> <ul style="list-style-type: none"> (a) an executive services agreement with the Rod Corps; (b) letters of appointment with each of its Non-Executive Directors on standard; and (c) deeds of indemnity, insurance and access with each of its Directors on standard terms. 	Sections 7.5, 7.6 and 7.7																																								
Who will be the substantial holders of the Company?	<p>Shareholders (and their associates) holding an interest in 5% or more of the Shares on issue as at the Prospectus Date are set out in the table below:</p> <table border="1"> <thead> <tr> <th>Name</th> <th>Shares</th> <th>%</th> </tr> </thead> <tbody> <tr> <td>Rod Corps</td> <td>1,500,001</td> <td>25%</td> </tr> <tr> <td>Warren Hallam</td> <td>1,750,001</td> <td>29.17%</td> </tr> <tr> <td>Metals X Limited</td> <td>1,100,000</td> <td>18.33%</td> </tr> </tbody> </table> <p>Based on the information known as at the Prospectus Date, on Admission (and following completion of the Distribution) the following persons will have an interest in 5% or more of the Shares on issue:</p> <table border="1"> <thead> <tr> <th rowspan="2">Shareholder</th> <th colspan="2">Minimum Subscription</th> <th colspan="2">Maximum Subscription</th> </tr> <tr> <th>Shares</th> <th>%</th> <th>Shares</th> <th>%</th> </tr> </thead> <tbody> <tr> <td>Metals X</td> <td>21,100,000</td> <td>26.05%</td> <td>21,100,000</td> <td>23.19%</td> </tr> <tr> <td>APAC Resources Strategic Holdings Limited</td> <td>4,948,833</td> <td>6.11%</td> <td>4,948,833</td> <td>5.44%</td> </tr> <tr> <td>Old Peak Group Limited</td> <td>4,091,572</td> <td>5.05%</td> <td>4,091,572</td> <td>4.49%</td> </tr> </tbody> </table>	Name	Shares	%	Rod Corps	1,500,001	25%	Warren Hallam	1,750,001	29.17%	Metals X Limited	1,100,000	18.33%	Shareholder	Minimum Subscription		Maximum Subscription		Shares	%	Shares	%	Metals X	21,100,000	26.05%	21,100,000	23.19%	APAC Resources Strategic Holdings Limited	4,948,833	6.11%	4,948,833	5.44%	Old Peak Group Limited	4,091,572	5.05%	4,091,572	4.49%	Sections 2.6 and 3.2				
Name	Shares	%																																								
Rod Corps	1,500,001	25%																																								
Warren Hallam	1,750,001	29.17%																																								
Metals X Limited	1,100,000	18.33%																																								
Shareholder	Minimum Subscription		Maximum Subscription																																							
	Shares	%	Shares	%																																						
Metals X	21,100,000	26.05%	21,100,000	23.19%																																						
APAC Resources Strategic Holdings Limited	4,948,833	6.11%	4,948,833	5.44%																																						
Old Peak Group Limited	4,091,572	5.05%	4,091,572	4.49%																																						

Topic	Summary	More information						
DIRECTORS, RELATED PARTY INTEREST AND SUBSTANTIAL HOLDERS (CONTINUED)								
What fees are payable to the Lead Managers?	<p>The Lead Managers are Blue Ocean Equities and Marketech Online Trading.</p> <p>As at the Prospectus Date the Lead Managers do not have any interests in any Securities of the Company.</p> <p>Based on the information available to the Company as at the date of the Prospectus regarding the Lead Managers and their associates' intentions in relation to the Public Offer, the Lead Managers and their associates will have a relevant interest in the following Securities on Admission (assuming the Minimum Subscription is raised):</p> <table border="1"> <thead> <tr> <th>Shares</th> <th>%</th> <th>Options</th> </tr> </thead> <tbody> <tr> <td>Nil</td> <td>-</td> <td>800,000</td> </tr> </tbody> </table>	Shares	%	Options	Nil	-	800,000	Section 2.6
Shares	%	Options						
Nil	-	800,000						
WHAT IS THE PUBLIC OFFER?								
What is the Public Offer?	The Public Offer is for an initial public offering of a minimum of 50,000,000 and a maximum of 60,000,000 Shares at an issue price of \$0.20 each to raise a minimum of \$10,000,000 and a maximum of \$12,000,000 (before associated costs).	Sections 2.1						
What is the Offer Price?	The issue price of Shares under the Public Offer is \$0.20 per Share.	Section 2.1						
What is the minimum subscription amount under the Public Offer?	The Public Offer is conditional on the Company raising at least \$10,000,000. If the Company fails to raise the Minimum Subscription within four months after the Prospectus Date, the Company will either repay the Application Monies (without interest) to Applicants or issue a supplementary prospectus or replacement prospectus and allow Applicants one month to withdraw their Applications and have their Application Monies refunded to them (without interest).	Section 2.1(c)						
What is the Distribution Offer?	<p>The offer to Eligible Metals X Shareholders of 25,000,000 Shares (Distribution Shares) to be issued to Metals X and distributed by Metals X to Eligible Metals X Shareholders if the Distribution is approved by Metals X Shareholders at the Metals X General Meeting.</p> <p>No funds will be raised by the Company under the Distribution Offer.</p>	Section 2.2						
Will the Shares be quoted?	<p>The Company will apply to the ASX for its admission to the Official List and for quotation of the Shares on the ASX (expected to be under the code "NC1") within seven days of the Prospectus Date.</p> <p>The Company will not apply for quotation of the Options on the ASX.</p>	"Corporate Directory" and Section 2.11						
What is the purpose of this Prospectus?	<p>The purpose of the Public Offer is to:</p> <ol style="list-style-type: none"> raise a minimum of \$10,000,000 and up to a maximum of \$12,000,000 pursuant to the Public Offer; assist the Company to meet the requirements of ASX and satisfy Chapters 1 and 2 of the Listing Rules, as part of the Company's application for admission to the Official List; and position the Company to seek to achieve the objectives detailed in Section 3. 	Section 2.1(d)						

Topic	Summary	More information
WHAT IS THE PUBLIC OFFER? (CONTINUED)		
What are the conditions of the Offers?	<p>The Offers under this Prospectus are conditional upon:</p> <ul style="list-style-type: none"> (a) the Company completing the Acquisition of Metals Exploration; (b) Metals X Shareholders approving the Distribution of the Distribution Shares; (c) the Company raising the Minimum Subscription (\$10,000,000) under the Public Offer; and (d) the ASX granting in-principle approval to admit the Company to the Official List on conditions which the Directors are confident can be satisfied. <p>If these conditions are not satisfied, then the Offers will not proceed and the Company will repay all Application Monies received under the Offers in accordance with the Corporations Act.</p>	Section 2.3
Are there any escrow arrangements?	<p>Yes, there are compulsory escrow arrangements under the ASX Listing Rules.</p> <p>None of the Shares issued pursuant to the Public Offer are expected to be restricted securities. All Securities issued to the Lead Managers (or their nominees) are expected to be restricted securities.</p> <p>The Company anticipates that upon Admission approximately 3,750,000 Shares will be classified as restricted securities by ASX (including 2,700,000 Shares restricted for a period of 24 months from quotation of the Company's Shares on ASX, and 1,050,000 Shares restricted for 12 months from the date of issue of those Shares) which comprises approximately 4.63% of the total issued Shares (based on the Minimum Subscription and assuming no Options exercised).</p> <p>Metals X proposes to hold in voluntary escrow and not sell 15,000,000 Shares (being 75% of the 20,000,000 Shares issued to Metals X under the Public Offer) for a period of 12 months from the date of Admission.</p>	Section 2.16
What is the Offer period?	An indicative timetable for the Public Offer is set out on page 3 of this Prospectus.	"Indicative Timetable"
Is the Public Offer underwritten?	No, the Public Offer is not underwritten.	Section 2.18
ADDITIONAL INFORMATION		
Will the Company be adequately funded after completion of the Public Offer?	The Board believes that the funds raised from the Public Offer will provide the Company with sufficient working capital to achieve its stated objectives as detailed in this Prospectus.	Section 2.4
What rights and liabilities attach to the Securities on issue?	<p>All Shares issued under the Public Offer will rank equally in all respects with existing Shares on issue. The rights and liabilities attaching to the Shares are described in Section 8.1.</p> <p>The terms and conditions of the Director Options, Metals X Options, and Lead Manager Options are set out in Section 8.2.</p>	Sections 8.1 and 8.2
Who is eligible to participate in the Public Offer?	The Public Offer is open to all investors with a registered address in Australia.	Section 2.15
How do I apply for Shares under the Public Offer?	Applications for Shares under the Public Offer can only be made using the relevant Application Form accompanying this Prospectus. For further information on how to complete the Application Form, Applicants should refer to the instructions set out on the form.	Section 2.9

Topic	Summary	More information
ADDITIONAL INFORMATION (CONTINUED)		
What is the allocation policy?	<p>The Directors, in consultation with the Lead Managers, will allocate Shares under the Public Offer at their sole discretion with a view to ensuring an appropriate Shareholder base for the Company going forward (subject to any regulatory requirements).</p> <p>There is no assurance that any Applicant will be allocated any Securities, or the number of Securities for which it has applied. The Company reserves the right to reject any Application or to issue a lesser number of Shares than those applied for. Where the number of Shares issued is less than the number applied for, surplus Application Monies will be refunded (without interest) as soon as reasonably practicable after the Closing Date.</p> <p>Subject to the satisfaction of the conditions to the Offers outlined in Section 2.3, Shares offered under this Prospectus are expected to be allotted on the Issue Date. It is the responsibility of Applicants to determine their allocation prior to trading in the Shares issued under the Offers. Applicants who sell Securities before they receive their holding statements do so at their own risk</p>	Section 2.13
When will I receive confirmation that my Application has been successful?	It is expected that holding statements will be sent to successful applicants on or about 24 December 2021.	"Indicative Timetable"
What is the Company's dividend policy?	The Company does not expect to pay dividends in the near future as its focus will primarily be on exploration of the Projects and future acquisitions.	Section 3.7
How can I find out more about the Prospectus or the Public Offer?	Questions relating to the Public Offer and the completion of an Application Form can be directed to the Company Secretary by email at info@nicoresources.com.au .	Section 2.23

02.

Details of the Offers

2.1 PUBLIC OFFER

(a) General

This Prospectus invites investors to apply for 50,000,000 Shares at an issue price of \$0.20 each to raise \$10,000,000 (before associated costs) (**Public Offer**).

The Shares to be issued pursuant to the Public Offer are of the same class and will rank equally with the existing Shares on issue. The rights and liabilities attaching to the Shares are further described in Section 8.1.

Applications for Shares under the Public Offer must be made on the Application Form accompanying this Prospectus and received by the Company on or before the Closing Date. Persons wishing to apply for Shares under the Public Offer should refer to Section 2.9(a) for further details and instructions.

The Shares to be issued under the Public Offer include 20,000,000 Shares to be subscribed for and issued to Metals X.

(b) Over-subscriptions to Public Offer

At the discretion of the Directors the Company may accept over-subscriptions to the Public Offer to raise up to an additional \$2,000,000 to the Public Offer by the issue of an additional 10,000,000 Shares at an issue price of \$0.20 (**Over-Subscription Shares**).

The acceptance of Applications for, and issue of, Over-Subscription Shares will be at the sole discretion of the Directors, who may elect to accept Applications for some, all or none of the Over-Subscription Shares applied for.

The maximum the number of Shares that may be issued under the Public Offer is 60,000,000 Shares, to raise a maximum of \$12,000,000 (before costs).

(c) Minimum Subscription

The minimum subscription under the Public Offer is \$10,000,000, being 50,000,000 Shares (**Minimum Subscription**).

None of the Shares offered under the Public Offer will be issued if Applications are not received for the Minimum Subscription. Should Applications for the Minimum Subscription not be received within four months from the Prospectus Date, the Company will either repay the Application Monies (without interest) to Applicants or issue a supplementary prospectus or replacement prospectus and allow Applicants one month to withdraw their Applications and have their Application Monies refunded to them (without interest).

(d) Purpose of the Public Offer

The purpose of the Public Offer is to:

- (i) raise a minimum of \$10,000,000 and up to \$12,000,000 (before associated costs of the Offers);
- (ii) assist the Company to meet the requirements of ASX and satisfy Chapters 1 and 2 of the Listing Rules, as part of the Company's application for admission to the Official List; and
- (iii) position the Company to seek to achieve the objectives detailed in Section 3.

2.2 DISTRIBUTION OF SHARES TO METALS X SHAREHOLDERS – DISTRIBUTION OFFER

The Distribution Offer comprises an offer by Metals X to Eligible Metals X Shareholders by way of a distribution in-specie of a total of 25,000,000 Shares (Distribution Shares) to be issued to Metals X as consideration for the Company's acquisition from Metals X of 100% of the shares in Metals Exploration Pty Ltd, which will result in the Company acquiring effective control and ownership of the CMP Project.

Subject to Metals X obtaining the approval of Metals X Shareholder at the Metals X General Meeting, to be held on or about 15 December 2021, it is Metals X's intention to distribute the Distribution Shares to Eligible Metals X Shareholders, by way of the Distribution.

Under the Distribution Offer, Eligible Metals X Shareholders are entitled to participate in a distribution in-specie of 25,000,000 Shares on a pro-rata basis in accordance with each Metals X Shareholder's holding of Metals X Shares. No cash amount is payable by Eligible Metals X Shareholders for the distribution of Distribution Shares to them and no amount will be raised by the Company from Distribution Offer.

The Distribution will result in a reduction of capital of Metals X (**Share Capital Reduction**). Accordingly, Metals X will seek Metals X Shareholder approval of the Share Capital Reduction at the Metals X General Meeting.

The Distribution Offer is subject to Metals X Shareholders approving at the Metals X General Meeting:

- (a) the distribution of 25,000,000 Shares to be issued to Metals X as consideration for the Acquisition, as described in the Metals X Notice of Meeting; and
- (b) the subsequent reduction in the capital of Metals X pursuant to section 256B of the Corporations Act.

If Metals X Shareholders do not approve the Share Capital Reduction, no Shares will be distributed under the Distribution Offer and no Shares will be issued under the Public Offer.

Eligible Metals X Shareholders will not be required to subscribe for Distribution Shares. Distribution Shares will be issued to Metals X by the Company at a deemed issued price of \$0.20 per Distribution Share, being the same issue price for Shares under the Share Offer, and will be distributed to Eligible Metals X Shareholders under the Distribution at no cash cost for Eligible Metals X Shareholders, subject to Metals X Shareholders approving the Distribution at the Metals X General Meeting.

The Metals X Notice of Meeting will be available at the website of Metals X at <https://www.metalsx.com.au/asx-announcements/>.

The Metals X Notice of Meeting contains information about the proposed Distribution, the conditions required to be satisfied for the Distribution to occur, Metals X's reasons for undertaking the Distribution, the advantages and disadvantages to Metals X Shareholders in respect of the proposed Share Capital Reduction, the sale of Metals Exploration to the Company and taxation consequences of the proposed Distribution for Metals X Shareholders.

A purpose of this Prospectus is to ensure that the Distribution Shares that are distributed to Eligible Metals X Shareholders with disclosure in accordance with the requirements of Part 6D.2 of the Corporations Act and to facilitate quotation of the Distribution Shares on ASX if the Company is admitted to the Official List of ASX.

2.3 CONDITIONS TO OFFERS

The Offers under this Prospectus are conditional upon the following events occurring:

- the Company completing the Acquisition under the Share Sale Agreement for the issue of 25,000,000 Shares to Metals X; the completion of the Acquisition is subject to satisfaction of a number of conditions as stated in Section 7.2;
- Metals X Shareholders approving the Distribution of the Distribution Shares and the Share Capital Reduction at the Metals X General Meeting;
- the Company raising the Minimum Subscription, being \$10,000,000, under the Public Offer (refer to Section 2.1(c)); and
- ASX granting in-principle approval to admit the Company to the Official List on conditions which the Directors are confident can be satisfied.

If these conditions are not satisfied, then the Offers will not proceed and the Company will repay all Application Monies received under the Offers in accordance with the Corporations Act.

2.4 PROPOSED USE OF FUNDS

Following the Offers, it is anticipated that the following funds will be available to the Company:

Source of funds	Minimum Subscription	Maximum Subscription
Existing cash as at the Prospectus Date	\$56,987	\$56,987
Proceeds from Public Offer	\$10,000,000	\$12,000,000
Total funds available	\$10,056,987	\$12,056,987

The following table shows the intended use of funds in the two-year period following Admission:

Proposed use of funds – Year 1	Minimum Subscription		Maximum Subscription	
	\$'000	%	\$'000	%
Exploration expenditure ¹	1,585	32.9%	1,771	34.1%
Studies and reviews	259	5.4%	311	6.0%
Directors' fees ²	400	8.3%	400	7.7%
General administration fees and working capital ³	786	16.3%	786	15.1%
Future acquisition costs ⁴	850	17.6%	850	16.4%
Transfer duty	260	5.4%	260	5.0%
Capital expenditure	12	0.2%	12	0.2%
Estimated expenses of the Offer ⁵	668	13.9%	803	15.5%
Total funds allocated – Year 1	4,820	100%	5,193	100%

Proposed use of funds – Year 2	Minimum Subscription		Maximum Subscription	
	\$'000	%	\$'000	%
Exploration expenditure ¹	1,995	53.2%	2,252	55.5%
Studies and reviews	259	6.9%	311	7.7%
Directors' fees ²	400	10.7%	400	9.8%
General administration fees and working capital ³	586	15.6%	586	14.4%
Future acquisition costs ⁴	500	13.3%	500	12.3%
Capital expenditure	12	0.3%	12	0.3%
Total funds allocated – Year 2	3,752	100%	4,061	100%
Total funds allocated – Years 1 and 2	8,572		9,254	

Notes:

1. See Section 3.6 for further information on the Company's proposed exploration budget.
2. See Section 6.5 for further information on the Directors' fees and remuneration.
3. Working capital includes the general costs associated with the management and operation of the business including administration expenses, rent, other associated costs and also surplus funds. The Directors will allocate surplus funds at their discretion in the event the Company raises more than the Minimum Subscription under the Public Offer.
4. Future acquisition costs include costs required for the identification of new projects and opportunistic acquisitions. The Company notes that:
 - (i) it is not currently considering other acquisitions;
 - (ii) that any future acquisitions are likely to be in the mineral resource sector;
 - (iii) that the timing of any such transactions is not yet known; and
 - (iv) if no suitable acquisition opportunity arises, and subject to the outcomes of exploration activities, the Company may elect to allocate some or all of these funds to exploration on the Company's existing Projects.
5. Expenses paid or payable by the Company in relation to the Offers are set out in Section 8.8.

The above table is a statement of current intentions as at the Prospectus Date. Investors should note that, as with any budget, the allocation of funds set out in the above table may change depending on a number of factors, including market conditions, the development of new opportunities and/or any number of other factors (including the risk factors outlined in Section 4), and actual expenditure levels, may differ significantly from the above estimates.

Although the Company's immediate focus will be on the Projects, as with most exploration entities, it will pursue and assess other new business opportunities in the resource sector over time which complement its business. If and when a viable investment opportunity is identified, the Board may elect to acquire or exploit such opportunity by way of acquisition, joint venture or earn-in arrangement which may involve the payment of consideration in cash, equity or a combination of both.

The Board believes that the funds raised from the Public Offer will provide the Company with sufficient working capital to achieve its stated objectives as detailed in this Prospectus.

The use of further equity funding may be considered by the Board where it is appropriate to accelerate a specific project or strategy.

Based on the intended use of funds detailed above, the amounts raised pursuant to the Public Offer will provide the Company sufficient funding for only 2 years' operations. As the Company has no operating revenue, the Company will require further financing in the future. See Section 4.1(c) for further details about the risks associated with the Company's future capital requirements.

2.5 CAPITAL STRUCTURE ON ADMISSION

On the basis that the Company completes the Offers on the terms in this Prospectus and assuming no further Securities are issued, on Admission the Company's capital structure will be as follows:

Shares	Minimum Subscription		Maximum Subscription	
	Number	%	Number	%
On issue as at the Prospectus Date ¹	6,000,002	7.41%	6,000,002	6.59%
To be issued to Metals X (and distributed to Eligible Metals X Shareholders under the Distribution Offer) ²	25,000,000	30.86%	25,000,000	27.47%
To be issued under the Public Offer ³	50,000,000	61.73%	60,000,000	65.93%
Total Shares on issue on completion of the Offers	81,000,002	100%	91,000,002	100%

Options	Number	%
Metals X Options ⁴	25,000,000	71.84%
Director Options ⁵	9,000,000	25.86%
Lead Manager Options ⁶	800,000	2.3%
Total Options on issue on completion of the Offers	34,800,000	100%

Notes:

1. Refer to Section 3.2 for further details relating to the Company's current capital structure.
2. Pursuant to the Share Sale Agreement, the Company has agreed to acquire Metals Exploration from Metals X in consideration for 25,000,000 Shares. Refer to Sections 3.1 and 7.2 for further details of the Acquisition and the Share Sale Agreement.
3. Includes 20,000,000 Shares to be subscribed for by Metals X under the Public Offer.
4. Options granted to Metals X on signing the Share Sale Agreement. Options exercisable at \$0.25 each within 3 years of the date of grant of the Options on the terms and conditions set out in Section 8.2.
5. Options granted to Directors (or their related entities) exercisable at \$0.20 each within 3 years of the date of grant of the Options on the terms and conditions set out in Section 8.3.
6. Pursuant to the Lead Manager Mandate, the Company has agreed to grant to Blue Ocean Equities (or its nominee) 800,000 Lead Manager Options exercisable at \$0.30 each within 3 years of the date of grant of the Options on the terms and conditions set out in Section 8.2.

2.6 SUBSTANTIAL SHAREHOLDERS ON ADMISSION

Based on the information known as at the Prospectus Date, on Admission and following completion of the Distribution of Shares to Eligible Metal X Shareholders, the following persons (and their associates) will have direct interests in 5% or more of the Shares on issue at the Minimum Subscription to the Public Offer (81,000,002 total Shares on issue) and at Maximum Subscription to the Public Offer (91,000,002 total Shares on issue):

Name	Minimum Subscription		Maximum Subscription	
	Shares	%	Shares	%
Metals X Limited	21,100,000	26.05%	21,100,000	23.19%
APAC Resources Strategic Holdings Limited (APAC) ¹	4,948,833	6.11%	4,948,833	5.44%
Old Peak Group Limited (Old Peak) ²	4,091,572	5.05%	4,091,572	4.49%

Notes:

1. APAC is Metals X Shareholder as at the Prospectus Date. Based on APAC's disclosed shareholding interest in Metals X (19.80%) as at the Prospectus Date, it is estimated that APAC will be entitled to approximately 4,948,833 Shares under the Distribution Offer.
2. Old Peak is a Metals X Shareholder as at the Prospectus Date. Based on Old Peak's disclosed shareholding interest in Metals X (16.36%) as at the Prospectus Date, it is estimated that Old Peak will be entitled to approximately 4,091,572 Shares under the Distribution Offer.

2.7 LEAD MANAGERS' INTEREST IN THE OFFERS

Blue Ocean Equities and Marketech Online Trading (also referred to in this Prospectus as the "Lead Managers") have been appointed as lead managers to the Public Offer and are parties to the Lead Manager Mandate that is summarised in Section 7.4.

The Company will pay the following fees to the Lead Managers pursuant to the Lead Manager Mandate, subject to the successful completion of the Public Offer:

- (a) a management fee of 2% on the total amount raised in the Public Offer; and
- (b) a capital raising fee of 4% on the total amount raised in the Public Offer (excluding any gross proceeds derived from applications by Metals X, Existing Shareholders, and new investors / shareholders introduced by the Company).

Pursuant to the Lead Manager Mandate, the Company has also agreed to issue to Blue Ocean Equities (or its nominees) 800,000 Lead Manager Options exercisable at \$0.30 each within 3 years of the date of grant of the Options on the terms and conditions set out in Section 8.2.

2.8 FORECASTS

The Directors have considered the matters detailed in ASIC Regulatory Guide 170 and believe that they do not have a reasonable basis to forecast future earnings on the basis that the operations of the Company are inherently uncertain. Accordingly, any forecast or projection information would contain such a broad range of potential outcomes and possibilities that it is not possible to prepare a reliable best estimate forecast or projection.

The Directors consequently believe that, given these inherent uncertainties, it is not possible to include reliable forecasts in this Prospectus.

Refer to Sections 3.1, 3.4 and 3.5 for further information in respect to the Company's proposed activities.

2.9 APPLICATIONS FOR SHARES UNDER PUBLIC OFFER

Applications for Shares under the Public Offer can only be made using the relevant Application Form accompanying this Prospectus or otherwise provided by the Company. For further information on how to complete the Application Form, Applicants should refer to the instructions set out on the form.

No brokerage, stamp duty or other costs are payable by Applicants. All Application Monies will be paid into a trust account. Applicants wishing to provide Application Monies via electronic funds transfer should follow the instructions on the Application Form or contact the Company.

(i) Option 1: Submitting an Application Form with a cheque

Investors may complete an Application Form which accompanies and forms part of this Prospectus. Investors must enclose a cheque, made payable to "NICO Resources Limited" and crossed "Not Negotiable" and mail or deliver both the Application Form (completed in accordance with the terms set out in the Application Form) and the cheque to the address set out on the Application Form by no later than the Closing Date.

Completed Application Forms and any accompanying cheques or confirmation of electronic funds transfer must be received by the Company before 5.00pm WST on the relevant Closing Date by being posted to the following address:

NICO Resources Limited
C/- Computershare
GPO BOX 52
MELBOURNE VIC 3001

(ii) Option 2: Submitting an Application Form and paying with BPAY

For online applications, Investors can apply online with payment made electronically via BPAY®. Investors applying online will be directed to use an online Application Form and make payment by BPAY®. Investors will be given a BPAY® biller code and a customer reference number unique to the online Application once the online Application Form has been completed.

2.9 APPLICATIONS (CONTINUED)

BPAY® payments must be made from an Australian dollar account of an Australian institution. Using the BPAY® details, Investors must:

- (A) access their participating BPAY® Australian financial institution either via telephone or internet banking;
- (B) select to use BPAY® and follow the prompts; enter the biller code and unique customer reference number that corresponds to the online Application;
- (C) enter the amount to be paid which corresponds to the value of Shares under the online Application;
- (D) select which account payment is to be made from;
- (E) schedule the payment to occur on the same day that the online Application Form is completed. Applications without payment will not be accepted; and
- (F) record and retain the BPAY® receipt number and date paid.

Investors should confirm with their Australian financial institution: whether there are any limits on the Investor's account that may limit the amount of any BPAY® payment; and the cut off time for the BPAY® payment.

Investors can apply online by following the instructions at <https://nicoresourcesipooffer.reachagency.com> and completing a BPAY® payment. If payment is not made via BPAY®, the Application will be incomplete and will not be accepted. The online Application Form and BPAY® payment must be completed and received by no later than the Closing Date.

An original, completed and lodged Application Form together with a cheque or confirmation of electronic funds transfer for any Application Monies, constitutes a binding and irrevocable offer to subscribe for the number of Securities specified in the Application Form. The Application Form does not need to be signed to be valid. If the Application Form is not completed correctly or if the accompanying payment is for the wrong amount, it may be treated by the Company as valid. The Directors' decision as to whether to treat such an Application as valid and how to construe amend or complete the Application Form is final, however an Applicant will not be treated as having applied for more Shares than is indicated by the amount of the cheque or electronic funds transfer for the Application Monies.

It is the responsibility of Applicants outside Australia to obtain all necessary approvals for the allotment and issue of Securities pursuant to this Prospectus. The return of a completed Application Form with the requisite Application Monies will be taken by the Company to constitute a representation and warranty by the Applicant that all relevant approvals have been obtained and that the Applicant:

- (a) agrees to be bound by the terms of the Offer;
- (b) declares that all details and statements in the Application Form are complete and accurate;
- (c) declares that, if they are an individual, they are over 18 years of age and have full legal capacity and power to perform all its rights and obligations under the Application Form;
- (d) authorises the Company and its respective officers or agents, to do anything on their behalf necessary for the Securities to be issued to them, including to act on instructions of the Company's Share Registry upon using the contact details set out in the Application Form;
- (e) acknowledges that the information contained in, or accompanying, the Prospectus is not investment or financial product advice or a recommendation that Securities are suitable for them given their investment objectives, financial situation or particular needs; and
- (f) acknowledges that the Securities have not, and will not be, registered under the securities laws in any other jurisdictions outside Australia and accordingly, the Securities may not be offered, sold or otherwise transferred except in accordance with an available exemption from, or in a transaction not subject to, the registration requirements of applicable securities laws.

The Offers may be closed at an earlier date and time at the discretion of the Directors, without prior notice. Applicants are therefore encouraged to submit their Application Forms as early as possible. However, the Company reserves the right to extend the Public Offer or accept late Applications.

Applications under the Public Offer must be for a minimum of 10,000 Shares (\$2,000) and then in increments of 2,500 Shares (\$500).

Applications for Shares under the Public Offer must be made on the IPO Application Form accompanying this Prospectus and received by the Company on or before the Closing Date. Persons wishing to apply for Shares should refer to Section 2.9(a) and the IPO Application Form for further details and instructions.

2.10 CHESS AND ISSUER SPONSORSHIP

The Company will apply to participate in CHESS. All trading on the ASX will be settled through CHESS. ASX Settlement, a wholly-owned subsidiary of the ASX, operates CHESS in accordance with the Listing Rules and the ASX Settlement Operating Rules. On behalf of the Company, the Share Registry will operate an electronic issuer sponsored sub-register and an electronic CHESS sub-register. The two sub-registers together make up the Company's principal register of Securities.

Under CHESS, the Company will not issue certificates to Security holders. Rather, holding statements (similar to bank statements) will be sent to Security holders as soon as practicable after allotment. Holding statements will be sent either by CHESS (for Security holders who elect to hold Securities on the CHESS sub-register) or by the Company's Share Registry (for Security holders who elect to hold their Securities on the issuer sponsored sub-register). The statements will set out the number of existing Securities (where applicable) and the number of new Securities allotted under this Prospectus and provide details of a Security holder's holder identification number (for Security holders who elect to hold Securities on the CHESS sub-register) or Security holder reference number (for Security holders who elect to hold their Securities on the issuer sponsored sub-register). Updated holding statements will also be sent to each Security holders at the end of each month in which there is a transaction on their holding, as required by the Listing Rules.

2.11 ASX LISTING AND OFFICIAL QUOTATION

Within 7 days after the Prospectus Date, the Company will apply to ASX for admission to the Official List and for the Shares, including those offered by this Prospectus, to be granted Official Quotation (apart from any Shares that may be designated by ASX as restricted securities). The Company will not apply for quotation of the Options on the ASX.

If ASX does not grant permission for Official Quotation within three months after the Prospectus Date (or within such longer period as may be permitted by ASIC) none of the Securities offered under the Public Offer will be allotted and issued. If no allotment and issue is made, all Application Monies will be refunded to Applicants (without interest) as soon as practicable or the Company will issue a supplementary prospectus or replacement prospectus and allow Applicants one month to withdraw their Applications and have their Application Monies refunded to them (without interest).

ASX takes no responsibility for the contents of this Prospectus. The fact that ASX may grant Official Quotation is not to be taken in any way as an indication of the merits of the Company or the Securities offered pursuant to this Prospectus.

2.12 APPLICATION MONIES TO BE HELD IN TRUST

Application Monies will be held in trust for Applicants until the allotment of the Shares under the Public Offer. Any interest that accrues will be retained by the Company.

2.13 ALLOCATION AND ISSUE OF SHARES

20,000,000 Shares which Metals X has agreed to apply for under the Public Offer will be allocated to Metals X.

The Directors will allocate a minimum of 30,000,000 Shares and a maximum of 40,000,000 under the Public Offer at their sole discretion, with a view to ensuring an appropriate Shareholder base for the Company going forward (subject to any regulatory requirements).

There is no assurance that any Applicant to the Public Offer will be allocated any Shares, or the number of Shares for which it has applied. The Company reserves the right to reject any Application under or to issue a lesser number of Securities than those applied for. Where the number of Securities issued is less than the number applied for, surplus Application Monies will be refunded (without interest) as soon as reasonably practicable after the relevant Closing Date.

Subject to the satisfaction of the conditions to the Offers outlined in Section 2.3, Shares offered under this Prospectus are expected to be allotted on the Issue Date. It is the responsibility of Applicants to determine their allocation prior to trading in the Securities issued under the Offers. Applicants who sell Securities before they receive their holding statements do so at their own risk.

2.14 RISKS

Prospective investors should be aware that an investment in the Company should be considered highly speculative and involves a number of risks inherent in the various business segments of the Company. Section 4 details the key risk factors which prospective investors should be aware of. It is recommended that prospective investors consider these risks carefully before deciding whether to invest in the Company.

This Prospectus should be read in its entirety as it provides information for prospective investors to decide whether to invest in the Company. If you have any questions about the desirability of, or procedure for, investing in the Company please contact your stockbroker, accountant or other independent adviser.

2.15 OVERSEAS APPLICANTS

No action has been taken to register or qualify the Securities, or the Offers, or otherwise to permit the offering of the Securities, in any jurisdiction outside of Australia.

The distribution of this Prospectus within jurisdictions outside of Australia may be restricted by law and persons into whose possession this Prospectus comes should inform themselves about, and observe, any such restrictions. Any failure to comply with these restrictions may constitute a violation of those laws.

This Prospectus does not constitute an offer of Securities in any jurisdiction where, or to any person to whom, it would be unlawful to issue this Prospectus.

It is the responsibility of any overseas Applicant to ensure compliance with all laws of any country relevant to his or her Application. The return of a duly completed Application Form will be taken by the Company to constitute a representation and warranty that there has been no breach of such law and that all necessary approvals and consents have been obtained.

2.16 ESCROW ARRANGEMENTS

The Company anticipates that ASX will classify certain of the Existing Shares and all of the Existing Options on issue in the Company, as well as the Lead Manager Options to be issued, as being subject to the restricted securities provisions of the Listing Rules. Classified Securities would be required to be held in escrow for up to 24 months and will not be able to be sold, mortgaged, pledged, assigned or transferred for that period without the prior approval of ASX. During the period in which these Securities are prohibited from being transferred, trading in Securities may be less liquid which may impact on the ability of a Security holder to dispose of their Securities in a timely manner.

None of the Shares issued pursuant to the Public Offer and none of the Shares distributed by Metals X under the Distribution Offer are expected to be restricted securities.

The Company anticipates that upon Admission approximately 3,750,000 Existing Shares will be classified as restricted securities by ASX (including 2,700,000 Shares restricted for a period of 24 months from quotation of the Company's Shares on ASX, and 1,050,000 Shares restricted for 12 months from the date of issue of those Shares), which:

- (a) based on the Minimum Subscription, comprises 4.63% of the issued share capital on an undiluted basis, and 3.29% on a fully diluted basis (assuming all Options are issued and exercised and that no other Securities are issued); and
- (b) based on the Maximum Subscription, comprises 4.12% of the issued Share capital on an undiluted basis, and 2.98% on a fully diluted basis (assuming all Options are issued and exercised and that no other Securities are issued).

The Company anticipates that upon Admission, all of the 34,000,000 Existing Options (comprising 25,000,000 Metals X Options and 9,000,000 Director Options) and all of the 800,000 Lead Manager Options (and any Shares issued on the exercise of those Options during the escrow period) will be classified as restricted securities by ASX for 24 months.

Prior to the Company's Shares being admitted to Official Quotation on the ASX, the Company will enter into escrow agreements with the recipients of any restricted securities in accordance with Chapter 9 of the Listing Rules, and the Company will announce to ASX full details (quantity and duration) of the Securities required to be held in escrow.

The Company has been notified by ASX that the 25,000,000 Shares to be issued to Metals X (or its nominee) as the consideration for the Acquisition (being the Shares the subject of the Distribution Offer) will not be classified as restricted securities by ASX.

Metals X has informed the Company that it will enter into a voluntary escrow undertaking with the Company pursuant to which Metals X will undertake to hold in voluntary escrow and not sell or dispose of 15,000,000 Shares (being 75% of the 20,000,000 Shares issued to Metals X under the Public Offer) for a period of 12 months from the date of Admission. The Shares subject to the voluntary escrow undertaking will comprise 18.52% of the total Shares on issue at Minimum Subscription to the Public Offer and 16.48% of the total Shares on issue at Maximum Subscription to the Public Offer.

2.17 FREE FLOAT

On completion of the Offers, the Company expects that it will have a “free float” (within the meaning of the Listing Rules) of in excess of 65% to satisfy a condition of Admission to ASX that the Company have a free float of at least 20%.

The “free float” comprises those Shares which are:

- (a) not subject to escrow restrictions; or
- (b) held by persons who are related parties (or Associates of related parties) of the Company (including the Shares held by Directors or their Associates – refer Section 6.4).

2.18 UNDERWRITING

The Public Offer is not underwritten.

2.19 COMMISSION

The Company reserves the right to pay a commission of up to 6% (exclusive of GST) of amounts subscribed through any Australian financial services licensee in respect of any Applications lodged and accepted by the Company and bearing the stamp of the Australian financial services licensee. Payment will be made subject to the receipt of a proper tax invoice from the Australian financial services licensee.

2.20 WITHDRAWAL

The Directors may at any time decide to withdraw this Prospectus and the Offers in which case the Company will return all Application Monies (without interest) within 28 days of giving notice of their withdrawal.

2.21 PRIVACY DISCLOSURE

Persons who apply for Securities pursuant to this Prospectus are asked to provide personal information to the Company, either directly or through the Share Registry. The Company and the Share Registry collect, hold and use that personal information to assess Applications for Securities, to provide facilities and services to Security holders, and to carry out various administrative functions. Access to the information collected may be provided to the Company's agents and service providers and to ASX, ASIC and other regulatory bodies on the basis that they deal with such information in accordance with the relevant privacy laws. If you do not provide the information required on the relevant Application Form, the Company may not be able to accept or process your Application.

An Applicant has a right to gain access to the information that the Company holds about that person subject to certain exemptions under law. A fee may be charged for access. Access requests must be made in writing to the Company's registered office.

2.22 PAPER COPIES OF PROSPECTUS

The Company will provide paper copies of this Prospectus (including any supplementary or replacement document) and the relevant Application Form to investors upon request and free of charge. Requests for a paper copy form should be directed to the Company Secretary at steve@miningcorporate.com.au.

2.23 ENQUIRIES

This Prospectus provides information for potential investors in the Company and should be read in its entirety. If, after reading this Prospectus, you have any questions about any aspect of an investment in the Company, please contact your stockbroker, accountant or independent financial adviser.

Questions relating to the Public Offer and the completion of an Application Form can be directed to the Company Secretary at info@nicoresources.com.au or +61 8 9481 0389.

03. Company Overview

3.1 COMPANY AND BUSINESS OVERVIEW

The Company was incorporated on 29 April 2021 in the State of Western Australia for the purpose of pursuing various mining opportunities in the resources sector designed to add shareholder value by acquiring, exploring, developing, evaluating and exploiting mineral resource project opportunities and, other than as disclosed in this Prospectus, has not undertaken any activities since incorporation.

Since incorporation, the Company has agreed to acquire 100% of the shares in Metals Exploration Pty Ltd (**Metals Exploration**) from Metals X Limited (**Metals X**) pursuant to the Share Sale Agreement. Metals Exploration holds 100% of the shares in:

- (a) Hinckley Range Pty Ltd (**Hinckley Range**), which is the registered holder of the Wingellina Nickel Cobalt Project tenements; and
- (b) Austral Nickel Pty Ltd (**Austral Nickel**), which is the registered holder of the Claude Hills Project tenements.

The Wingellina Nickel-Cobalt Project and Claude Hills Project (together the Central Musgrave Project (**CMP**)) comprise tenements, substantial lateritic nickel-cobalt Mineral Resources and Ore Reserves, accompanying data and related infrastructure located adjoining Surveyor Generals' Corner, the junction between Western Australia, the Northern Territory and South Australia.

The tenements which comprise the Central Musgrave Project are described in 3.4.

Refer to Section 7.2 for a summary of the material terms of the Share Sale Agreement.

Following completion of the Offers and the Share Sale Agreement, the Company will hold via its subsidiaries a 100% legal and beneficial interest in the Tenements.

The Company has undertaken seed capital raisings (**Seed Raisings**) since incorporation by the issue of 6,000,000 Shares to sophisticated and institutional investors to raise a total of \$450,000 (before costs) issue prices of \$0.05 and \$0.10 per Share in order to capitalise the Company and facilitate the proposed listing on ASX (with any additional funds to be used as working capital during the listing process).

The Company's Board comprises Messrs Rod Corps (Managing Director), Warren Hallam (Non-Executive Chairman) and Brett Smith (Non-Executive Director). The Company Secretary is Ms Amanda Burgess.

Further information about the Board and management is set out in Section 6.

3.2 CURRENT CAPITAL STRUCTURE

As at the Prospectus Date, the capital structure of the Company, and particulars of its current Security holders (and their related entities), are as follows:

Security holder ¹	Shares ¹	%	Options ²	%
Rod Corps	1,500,001	25.0%	3,000,000	8.82%
Warren Hallam	1,750,001	29.17%	3,000,000	8.82%
Brett Smith	Nil	-	3,000,000	8.82%
Metals X Limited	1,100,000	18.33%	25,000,000	73.53%
Other Seed Raising investors	1,650,000	27.50%	-	-
Securities on issue as at the Prospectus Date	6,000,002	100%	34,000,000	100%

Notes:

1. Refer to Section 8.1 for a summary of the rights attaching to the Shares.
2. Refer to Sections 8.2 and 8.3 for the terms and conditions of the Options.

3.3 CORPORATE STRUCTURE

Upon completion of the Public Offer and the acquisition of Metals Exploration under the Share Sale Agreement (Acquisition), the Company's corporate structure will be as set out in the following diagram assuming a total of 81,000,002 Shares are on issue on completion of the Offers:

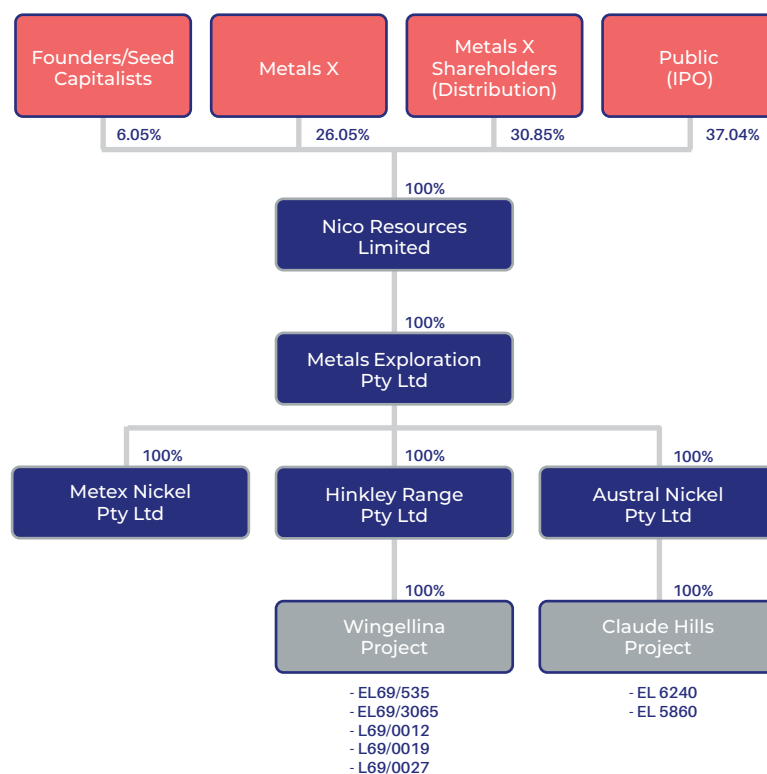

As at the Prospectus Date, the Company does not have any subsidiaries. On completion of the Public Offer and the Acquisition, the Company will have the following subsidiaries:

- Metals Exploration Pty Ltd (100%);
- Hinkley Range Pty Ltd (100%);
- Austral Nickel Pty Ltd (100%); and
- Metex Nickel Pty Ltd (100%).

3.4 CENTRAL MUSGRAVE PROJECT (CMP)

3.4.1. PROJECT LOCATION AND OVERVIEW

The Central Musgrave Project is located within Western Australia and South Australia adjacent to the Gunbarrel Highway immediately to the southwest of Surveyor Generals' Corner, the junction between Western Australia, Northern Territory and South Australia.



Figure 1 - Central Musgrave Project location

The Project consists of three exploration licences covering Wingellina, Claude Hills and Mt Davies, an exploration licence covering a calcrete deposit and three miscellaneous licences covering future infrastructure including the proposed water bore fields.

Wingellina and Claude Hills (located approximately 20km east of Wingellina) contain a significant Mineral Resource estimate of over 200 million tonnes of ore, containing approximately 1.95 million tonnes of nickel and 151,000 tonnes of cobalt along with a significant inventory of scandium and iron.

A Phase 1 Feasibility Study was undertaken in 2008, a land access agreement signed in 2010 and EPA approval to develop the project was obtained in 2016. Since 2016 Metals X has continued to undertake additional metallurgical optimisation, processing and infrastructure studies.

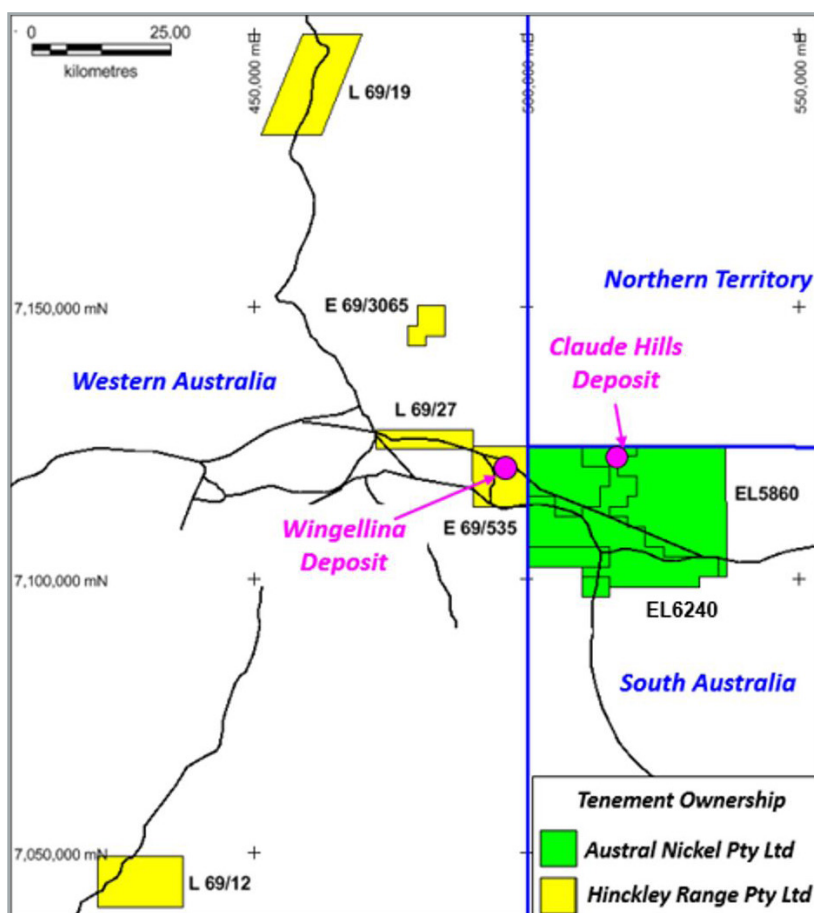

Figure 2 - Central Musgrave Project Tenements location

Details of the Tenements comprising the CMP are set out below:

Project & location	Tenement	Registered Holder	Status	Area (BI)	Grant Date	Expiry Date
Wingellina WA	E69/535	Hinckley Range (100%)	Granted	36 blocks	23 December 1993	22 December 2021
	E69/3065	Hinckley Range (100%)	Granted	12 blocks	5 June 2013	4 June 2023
	L69/12	Hinckley Range (100%)	Granted	14,492.5 ha	26 February 2009	25 February 2030
	L69/19	Hinckley Range (100%)	Granted	20,392.7 ha	29 August 2013	28 August 2034
	L69/27	Hinckley Range (100%)	Granted	6,195 ha	13 June 2018	12 June 2039
Claude Hills SA	EL5860	Austral Nickel (100%)	Granted	572 km ²	20 June 2016	19 June 2021 (renewal pending)
	EL6240	Austral Nickel (100%)	Granted	338 km ²	24 September 2017	23 September 2022

A comprehensive summary of regional and local geology, historical mining and historical exploration pertaining to the Tenements is contained in the Independent Technical Assessment Report in Schedule 3 of this Prospectus.

A comprehensive summary of the status of the Tenements can be found in the Solicitors' Report in Schedule 2 of this Prospectus.

3.4 CENTRAL MUSGRAVE PROJECT (CMP) (CONTINUED)

3.4.2. PROJECT HISTORY

The first deposits of nickeliferous limonites in weathered ultramafic rocks of the Giles Complex were noted by South Australian government geologists in the Mt Davies area, in the far north-west of South Australia in 1954. This led to the discovery of nickeliferous limonites at Wingellina by Nickel Mines of Australia Limited and Southwestern Mining Ltd (a wholly owned subsidiary of INCO Ltd) who held the exploration tenure in joint venture in 1956. INCO initially interpreted the nickeliferous limonites outcrops as a very large gossan which may reflect an underlying sulphide deposit. Exploration continued sporadically up until 1971, mainly between 1957 and 1960, and 1965 and 1970 with the many phases of drilling and geological evaluation concluding that the nickeliferous limonite deposits formed from the oxidation of nickeliferous silicate minerals within the dunite hosts of the Wingellina layered intrusive complex.

In 1975 Aboriginal Reserve 17614 was proclaimed over the area and exploration and mining were no longer permitted in the region. The project sat dormant from 1971 to 2000 until applications and land access agreements between Acclaim Exploration NL (**Acclaim**) and the traditional owners were reached in 2001. A small amount of exploration work was completed by Acclaim from 2001 to 2004.

In March 2005 Metals X entered into an agreement with Acclaim to earn an 80% interest in the Project by free carrying Acclaim to the completion of a bankable feasibility study. In February 2006, Metals X acquired all interests in the Project area from Acclaim.

A Phase 1 Feasibility Study, utilising high pressure acid leach (HPAL) processing was completed in 2008 (+ 25%) which indicated a robust project,

Since 2008 Metals X has also completed comprehensive bench-scale metallurgical test work, geotechnical diamond drilling, extensive flora and fauna studies, site engineering testing, logistics investigations and feed and waste characteristics in preparation for a bankable feasibility study. Studies have included the production of mixed hydroxides, mixed sulphides, nickel and cobalt sulphates and scandium, process alternatives including PosNep (POSCO proprietary technology). Ammonia leaching, oxide flotation and Ion exchange. Recent studies have reviewed high grade cobalt and nickel start-up options.

On 16 July 2010, Hinckley Range Pty Ltd (a wholly owned subsidiary of Metals Exploration), the Yarnangu Ngaanyatjarraku Parna Aboriginal Corporation, the Ngaanyatjarra Council (Aboriginal Corporation) and the Ngaanyatjarra Land Council (Aboriginal Corporation) executed the Wingellina Project Agreement which provides for the future grant of mining leases, the construction and operation of the future Wingellina mine and details the associated compensation considerations.

In September 2016 after the submission of a final Public Environmental Review in August 2015, EPA approval was obtained to proceed with the implementation of the Wingellina Nickel Project proposal.

NICO's objective is to move the Wingellina project towards development. A review of all previous works and studies will be undertaken to identify any additional information or programmes required to undertake a comprehensive feasibility study update, including the exploitation of the resources, infrastructure requirements, approvals and local sources of calccrete and water.

These studies will include undertake various exploration programs to determine how best to mine and process the potential high-grade zones of nickel, cobalt and scandium at both the Wingellina and the Claude Hills deposits.

Further metallurgical testwork and optimisation studies will also be undertaken to maximise the value of minerals extracted from the Projects.

3.4.3. MINERAL RESOURCES

The combined Mineral Resource and Ore Reserve estimates of the two Projects that together comprise the CMP are as follows:

Wingellina Combined Mineral Resources of 182.6Mt at 0.92% Ni and 0.07% Co for 1.68Mt of contained nickel and 132Kt of contained cobalt.

Probable Ore Reserves of 168.4Mt at 0.93% Ni and 0.07% Co for 1,561Kt of contained nickel and 123Kt of contained cobalt.

Claude Hills Inferred Mineral Resources of 33.3 Mt at 0.81% Ni and 0.07% Co for 270Kt of contained nickel and 23Kt of contained cobalt.

There is also other known similar mineralisation within the CMP tenements which have not yet been explored in any detail. In addition, within the Musgrave Block there is also the potential for the discovery of nickel sulphide deposits, such as the Nebo-Babel (290Mt @ 0.31% Ni & 0.34% Cu) owned by Oz Minerals Limited.

Further details of the Mineral Resources and Ore Reserves of the Projects are contained in the Independent Technical Assessment Report in Schedule 3 of this Prospectus.

3.4.4. GEOLOGICAL OVERVIEW

The CMP covers approximately 1,469km² of the mid-Proterozoic Musgrave Block, an east-west trending belt of granulite-gneiss basement rocks approximately 500km long. Within this area is the economically significant Giles Complex which comprises over twenty-one separate layered ultramafic, mafic and anorthositic intrusions. Deep weathering of the Giles Complex rocks has developed substantial high metallurgical purity, limonite rich lateritic nickel-cobalt deposits.

In the Giles Complex, primary mineralisation occurs in three known styles:

- primary (magmatic sulphide) nickel-copper-platinum group elements, as occurs at the Nebo and Babel discoveries of BHP, near Jamieson;
- secondary (oxide) nickel-cobalt mineralisation associated with the weathering of ultramafic rocks of the Giles Complex as at Wingellina; and
- vanadium and titanium magnetite bands associated with the most fractionated and highly evolved portions of the gabbro-troctolite intrusions, as occur in the Jamieson Ranges.

(a) Wingellina geology

The Wingellina nickel-cobalt oxide deposits occur in deeply weathered ultramafic (olivine-rich) members of the Hinckley Range gabbro, a component of the Giles Complex deep weathering.

The nickel mineralisation was produced by deep weathering, facilitated by shearing, of olivine-rich ultramafic units in the Wingellina Hills near the northern contact of the Hinckley Range gabbro. Olivine crystals within the ultramafic units originally contained background values of about 0.15% to 0.3% Ni. The almost complete removal of MgO and SiO₂ by downward-percolating ground waters during weathering resulted in extreme volume reductions and consequently significant upgrading of Fe₂O₃, Al₂O₃ and the metal elements Ni and Co in the weathered profile. The ultramafic units are deeply weathered into asymmetric trough-like shapes that are up to 250 metres deep in places. The geological contacts between the completely weathered ultramafic units and the intervening gabbroidal units are transitional.

The lateritic nickel deposits have an aggregate strike length (north-westerly) of about 8.5 kilometres, and an average width across strike length of about 1 kilometre. They cover a combined area of about 1,700 hectares. An approximate width for individual oxidised ultramafic units is about 80 metres, and their surface expressions in the form of surficial haematitic accretions and associated magnesite nodules can be traced over strike distances of several kilometres.

Manganese is known to be highly mobile in the weathering environment, and irregular pods and layers of manganese oxide, enriched especially in cobalt, have formed within the mineralised zones. The distribution of the higher-grade cobalt zones are constrained by their association with high grade nickel mineralisation within relatively shallow upper parts of the deposit. The high-grade mineralised zones show excellent continuity over several hundred metres of strike. Recent modelling of these resources has defined 15 mineable high-grade Ni-Co starter pits in the deposit.

The Wingellina nickel deposit is classified as a nickeliferous limonite resource with high iron (as hydrated oxides) and low magnesium oxide, with the higher grades of nickel and cobalt mineralisation being associated with manganese-rich pods and layers that occur in the upper parts of the mineralised profiles. The weathering of the feldspathic components of the intervening gabbro and minor pyroxenite units are major contributors to the relatively high aluminium composition of the mineralisation.

3.4 CENTRAL MUSGRAVE PROJECT (CMP) (CONTINUED)

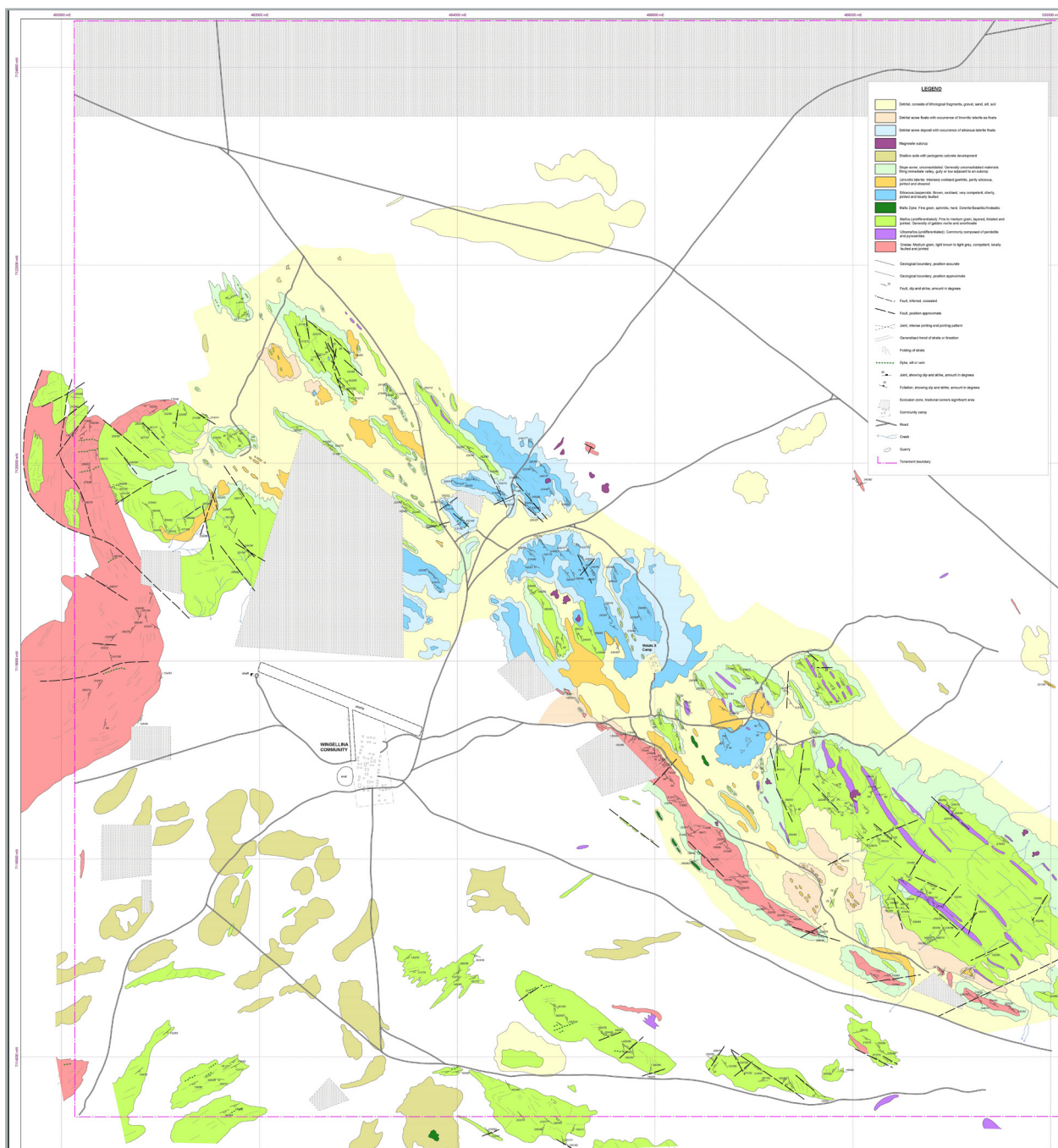

Figure 3 – Geology of the Wingellina Ni-Co Deposit

For personal use only

For personal use only

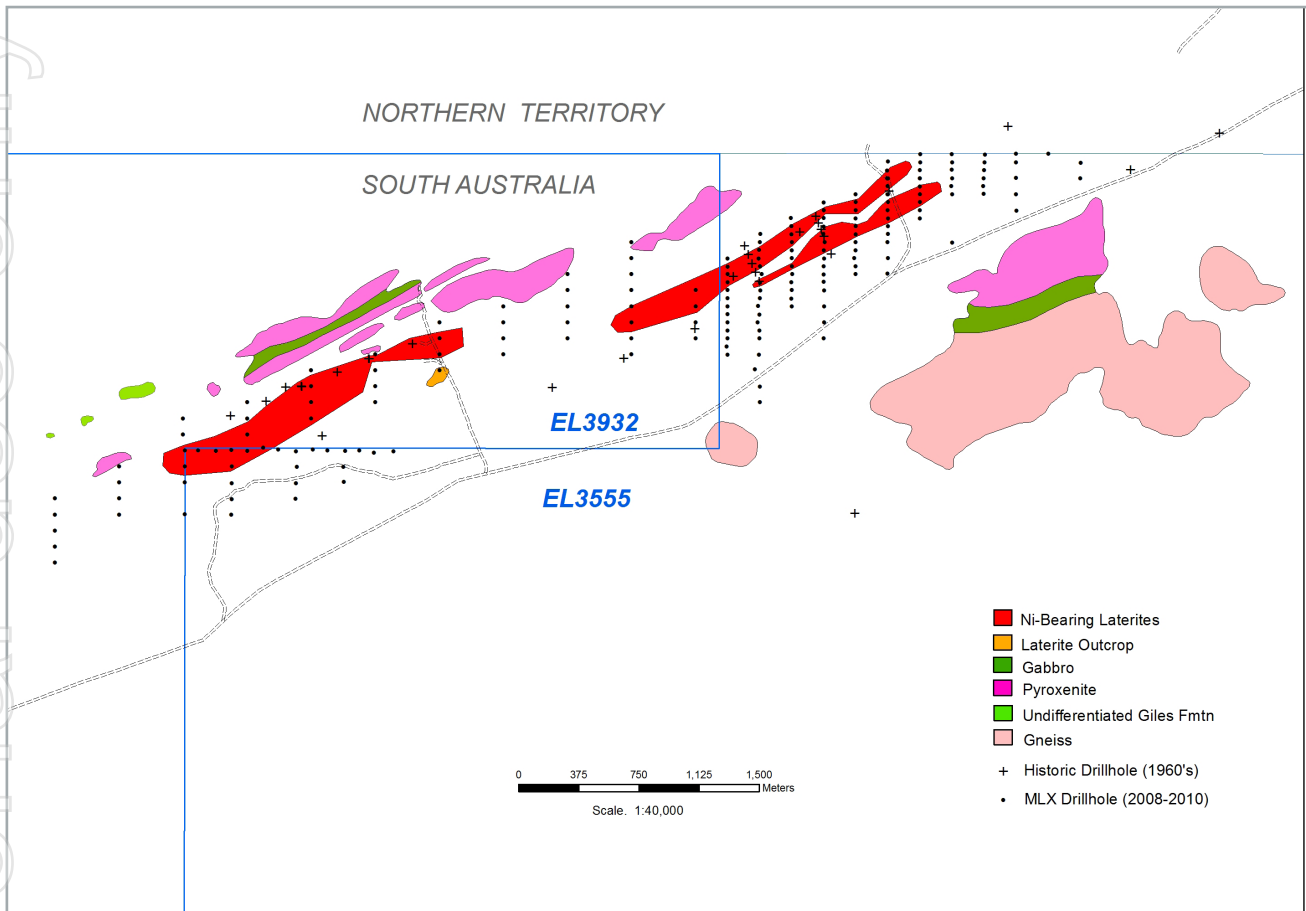

Figure 4 - Generalised cross-sections through the Wingellina deposit

3.4 CENTRAL MUSGRAVE PROJECT (CMP) (CONTINUED)

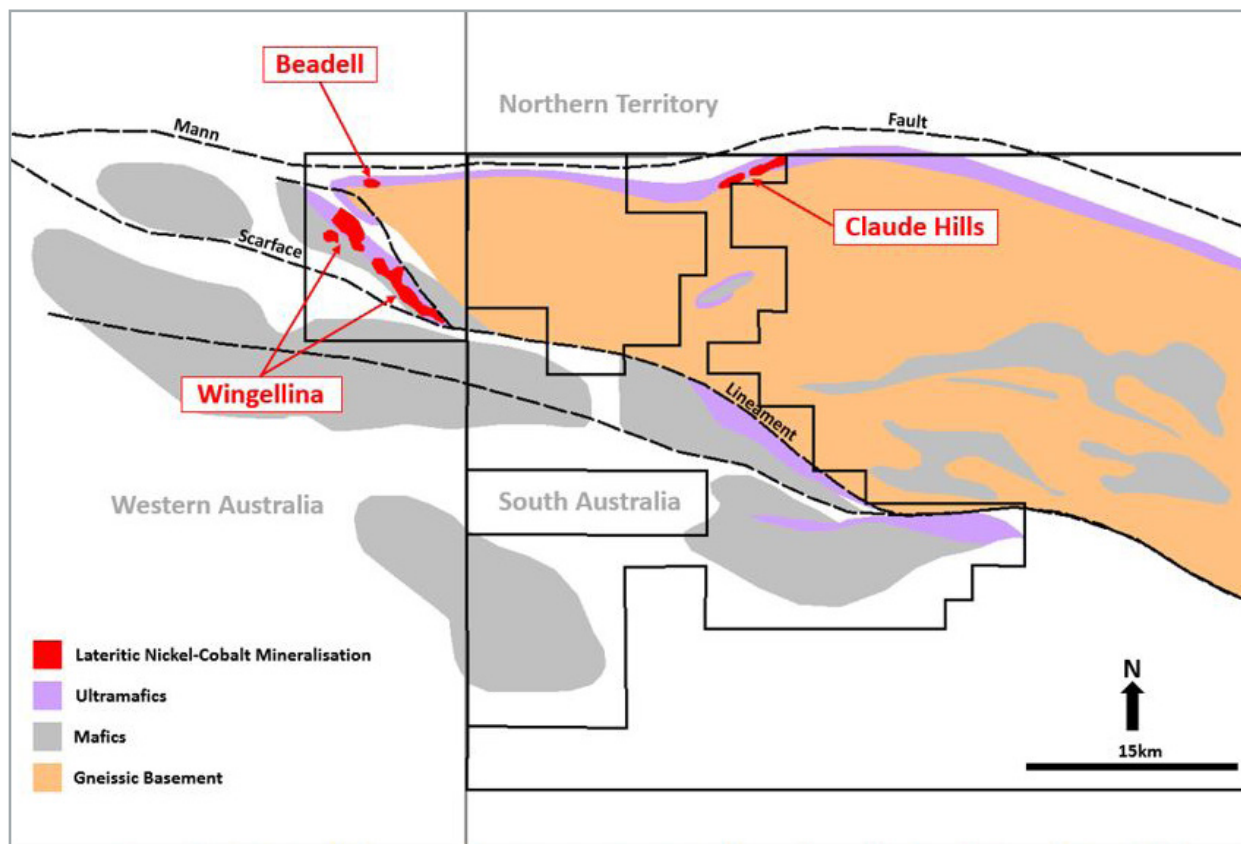

Figure 5 - Central Murchison Project showing the Wingellina, Claude Hills and Beadell deposits and the potential target zone along the contact of the Ultramafics (purple zones) and Gneissic Basement.

(b) Claude Hills deposit

The Claude Hills deposit is located in South Australia approximately 20km east of Wingellina and proximal to the Northern Territory border (Figure 5). The deposit is located on exploration licences EL6240 and EL 5860 and falls within freehold lands owned by the Anangu Pitjantjatjara Yankunytjatjara (APY).

The tenure and activities in South Australia are through Metals Exploration's 100% owned subsidiary Austral Nickel Pty Ltd (Figure 2).

The first deposits of nickel oxides in weathered rocks in the region were located by South Australian government geologists in the Mount Davies area in 1953. Since 1956 various exploration programs for nickel oxides and Sulphides have been undertaken by Southwestern Mining, SA Department of Mines and Energy, Primary Industry and Regions South Australia (PIRSA), Acclaim Exploration and Rio Tinto Exploration in joint venture with Delta Gold Limited.

In November 2009 a farm-in and joint venture agreement was signed between Austral and Rio Tinto whereby Austral could earn up to 70% interest in EL3932 (replaced by EL5860) (Mount Davies tenement). A key reason for this JV was that the Claude Hills laterites were found to straddle the project boundary within the Mt Davies tenement (EL5860). In August 2013 Metals X subsequently acquired the remaining Rio Tinto project equity and have drilled over 264 RC holes for 15,873m in the Claude Hills area.

(c) Claude Hills local geological setting

The Claude Hills nickel oxide deposits occur in deeply weathered ultramafic members of the Giles Complex, which has intruded gneisses of the Musgrave Block. The Claude Hills deposit comprises a sequence of pyroxenites and lesser dunites, with minor gabbros, striking east-northeast and facing upward to the south. The sequence is different from that seen at Wingellina, and the Claude Hills belt is now thought to be a separate intrusion. It contains a larger proportion of pyroxenite, and a smaller percentage of gabbroic rocks. This means the parent rocks to the Claude Hills laterites are much lower in aluminium than the Wingellina belt, and the resultant nickel-bearing laterites are commensurately lower in Al_2O_3 . The lateritic profile contains a high proportion of ferruginous silcrete layers.

To the north the sequence is truncated by the Mann Fault, which strikes along the northern boundary of the Exploration Licence. A series of north-northwest-trending brittle (?) dextral faults are also seen to offset the geology in several places.

Layering in the intrusions was caused by crystal fractionation and settling within individual melts of multiple magma injections. The basal dunitic part of the sequence does not outcrop, and it may have been removed by movement along the Mann Fault.

(d) Claude Hills mineralisation

Nickeliferous laterite is restricted to a layered mafic-ultramafic intrusion with substantial thicknesses of dunite and / or peridotite ultramafic. The Claude Hills oxide nickel deposit is a surficial, tropical laterite style of mineralisation developed over olivine-rich ultramafic and pyroxenite stratigraphy.

The nickel oxide resource comprises three parallel zones of limonitic and saprolitic styles of laterite mineralisation. The current level of drilling information is such that these zones may partially merge with additional drilling. These zones strike east-northeast over a distance of approximately 5.5km. The widths of individual mineralised zones can be seen to exceed three hundred metres, with depths of greater than fifty metres also observed.

Deep weathering of olivine-rich ultramafic units has resulted in the concentration of nickel mineralisation is similar to Wingellina, however the weathering has not been as intense, deep or widespread in the Claude Hills dunites with relatively fresh dunite intersected at shallow depths in some marginal areas. Silica dissolved from the olivines during weathering has accumulated into more defined silcrete layers in the laterite profile at Claude Hills than that seen at Wingellina.

Manganese is known to be highly mobile in the weathering environment, and irregular pods and layers of manganese oxide, enriched especially in cobalt, have formed within the mineralised zones. This is not as pronounced as at Wingellina. The distribution of these zones is poorly defined.

In general, the deposits at Claude Hills can be classified in the main as a nickeliferous with high iron (as hydroxides) and low magnesium and aluminium oxides, with the main source of cobalt mineralisation being associated with manganese rich pods and layers that occur in the upper parts of the mineralised profiles.

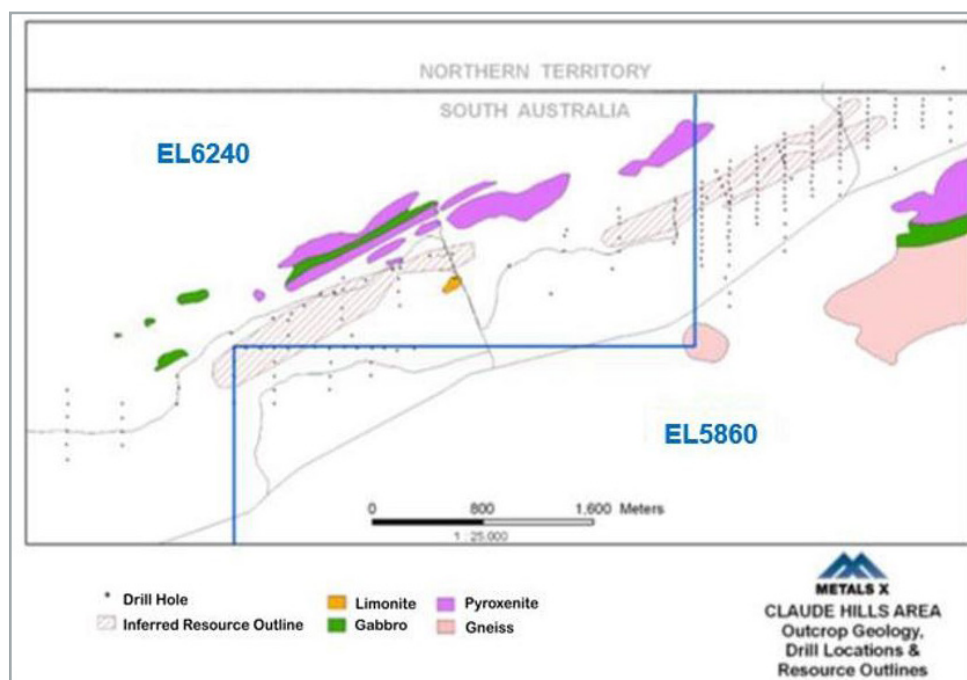

Figure 6 - Claude Hills Deposit Geology & Drill Hole Locations

Additional infill RC drilling is planned by NICO is to be undertaken to close drill line spacings to 100m at 25m centres on EL6240 (present data is based on 400m spaced lines and drill centres of 100m) and also to close down 100m line at 25m drill spacings on adjoining EL5860 (present data is based on to 200m line spacings and 50m drill centres). This will provide better definition for the evaluation of the high-grade Ni-Co zones the overall resource at Claude Hills for feasibility study purposes.

3.4 CENTRAL MUSGRAVE PROJECT (CMP) (CONTINUED)

3.4.5. 2008 PHASE 1 FEASIBILITY STUDY

A Phase 1 Feasibility Study (**PIFS**) was undertaken by Metals X in 2008 with the primary objective to identify and recommend the best construction and operating scenario for development. This was achieved by completing detailed studies of key aspects of the Projects including equipment, infrastructure, capital and operating cost estimates with an accuracy of estimate of $\pm 25\%$.

The Company has had the PIFS reviewed by the Independent Geologist and has received recommendations on the best approach required to update the results of these studies and move the CMP Project forward to a PFS-level of confidence in accordance with the JORC Code and VALMIN reporting standards. The Company aspires to commence the required work to advance the CMP Project to a PFS within the first two years after Admission.

(a) Description of Phase 1 Feasibility Study

A general description of the PIFS is as follows:

- **Mineral Resource basis:** The identified 2008 Mineral Resource estimate at 0.5% Ni cut-off of 183Mt @ 0.98% Ni, 0.08% Co and 46.95% Fe_2O_3 was used as the basis for all mining studies.
- **Mining strategy:** The overall mining strategy is to mine a number of staged open pit mines using conventional methods at a rate of 4.3 million tonnes per annum. The scheduling philosophy is to optimise the schedule by extracting the highest head grade material and lowest strip ratio first.

It is planned that ore will be stockpiled and, in some instances blended as it is fed into the primary crusher using front end loaders.

Apart from small areas of siliceous and calcareous cap-rock and a very small volume of narrow but harder bands of gabbro which transect the ore, the vast bulk of the mining is able to be freely excavated. A conservative assumption that 10% of in-pit material may require blasting has been applied in the mining cost calculation.

The stripping ratio for the first 20 years of operation is 0.5:1, facilitating the limitation of size of surface waste dumps, and minimising overall operating cost. Consequently, a higher overall strip ratio is required in the remaining years of the project, with the final average strip ratio estimated at 1.1:1. It is expected that in pit dumping of waste will be able to be employed later in the mine life when full sections of the ore body have been mined out.

- **Processing:** ROM ores are planned to be crushed, ground to 100% passing 500 μm and then subjected to HPAL. The process plant design incorporates three parallel autoclave trains. Following HPAL the discharge slurry is neutralised in two stages using locally sourced calccrete in order to remove impurities. The first stage neutralisation precipitate is washed and neutralised to pH 7.5 using slaked lime and discharged to tailings while the second stage neutralisation precipitate is recycled to the HPAL discharge where it is re-leached. A nickel-cobalt hydroxide is then precipitated in two stages from the purified solution, the first stage is the saleable product produced at the mine which is precipitated at pH 5.5 to 6.5 using magnesia. The second stage of hydroxide precipitation is a scavenger precipitate produced using hydrated lime at pH 6.5 to 7.5 and is recycled to the autoclave discharge for re-leaching. The final liquor is further neutralised using hydrated lime at a pH of 7.5 to 8.5 to remove manganese. The manganese precipitate is directed to neutralisation tanks prior to discharge in the tailings facility, while the barren solution is recycled for use as in the CCD washing process. A simplified block diagram of the MHP flow sheet proposed to treat Wingellina ore is shown in Figure 7.
- **Tailings:** The tailings storage facility is located approximately 0.5km to the north-east of the processing plant at the closest point. The tailings storage facility is a central discharge, with thickened tailings deposition. Approximately 200m³/h of water is recovered in the tailings thickener and recycled into the calccrete and lime preparation circuits. Recycle water is not used in the autoclaves as the high magnesium mineral content is likely to accelerate scaling.
- **Chemical and acid requirements:** Acid for the leaching process is planned to be generated in a sulphur burning plant at the site with approximately 390,000 tonnes per annum of elemental sulphur being the main reagent transported to site. The elemental sulphur is expected to be imported through the Darwin Port and hauled by rail approximately 1,300km to the Impadna siding (which is the siding closest to the Lasseter Highway) in the Northern Territory. At the Impadna siding, the sulphur is transferred to road haulage and hauled to site via a combination of the Lasseter Highway, and a proposed new road constructed for the project (via Uluru). The total road haulage requirement is approximately 541km.

- Water:** The raw water requirement for the processing plant is approximately 1200 m³/hour and is planned to be sourced from a borefield approximately 100km to the north of the processing plant. The water quality is good at between 1000 and 2000 ppm of dissolved solids. The borefield will source water from the Cobb Embayment, a sedimentary structure within the Canning Basin. The majority of the raw water requirement is direct feed to the process plant, however a water treatment plant is to be installed at the processing plant in order to meet the design requirements in various sections of the plant. An alternative water source also exists to the south-west of the project within the Lungkarta sandstone which forms part of the extensive Officer Basin.
- Power:** Power for the operation will be generated in a cogeneration plant using steam produced in the sulphur burning acid plant, and natural gas supplied from the Mereenie Gas field, located approximately 400km to the north-east. Total connected power is approximately 53.5MW, with a consumption rate of 37.3MW. The power plant design consists of two 22MW extraction steam turbine generators and one 20MW gas fired turbine generator with heat recovery stem generation. The gas consumption rate is 5.7 TJ/day under normal operation, and approximately 13TJ/day during acid plant outages. The processing plant is designed to operate at 50% capacity during acid plant outages.
- Calcrete:** Locally sourced calcrete is the primary source of neutralisation material in the process. Sources of high quality calcrete located within 30km of the processing plant have been outlined.
- Product export:** Export of the final product, a mixed nickel and cobalt hydroxide is by the same transport routes as the inbound reagent products. Subsequent studies have also shown that a mixed sulphide can be produced or high nickel and cobalt sulphates.
- Employees:** All employees will be on a site-based contract, working on a two week on, one week off fly in fly out roster arrangement. Employees are provided with air transport to and from the site, and are housed in an accommodation facility at the site during work time. The accommodation and entire project area is to be operated as an alcohol free environment. Extensive recreation facilities and healthy living alternatives are to be offered as a substitute to alcohol consumption at the mine.
- Health, safety and environment:** All operations are planned to be undertaken with upmost cognisance for health and safety of internal and external stakeholders, the minimisation of environmental impact, and the protection and respect for Aboriginal heritage and cultural values. The project plan includes maximisation of employment, training and participation of local indigenous people.

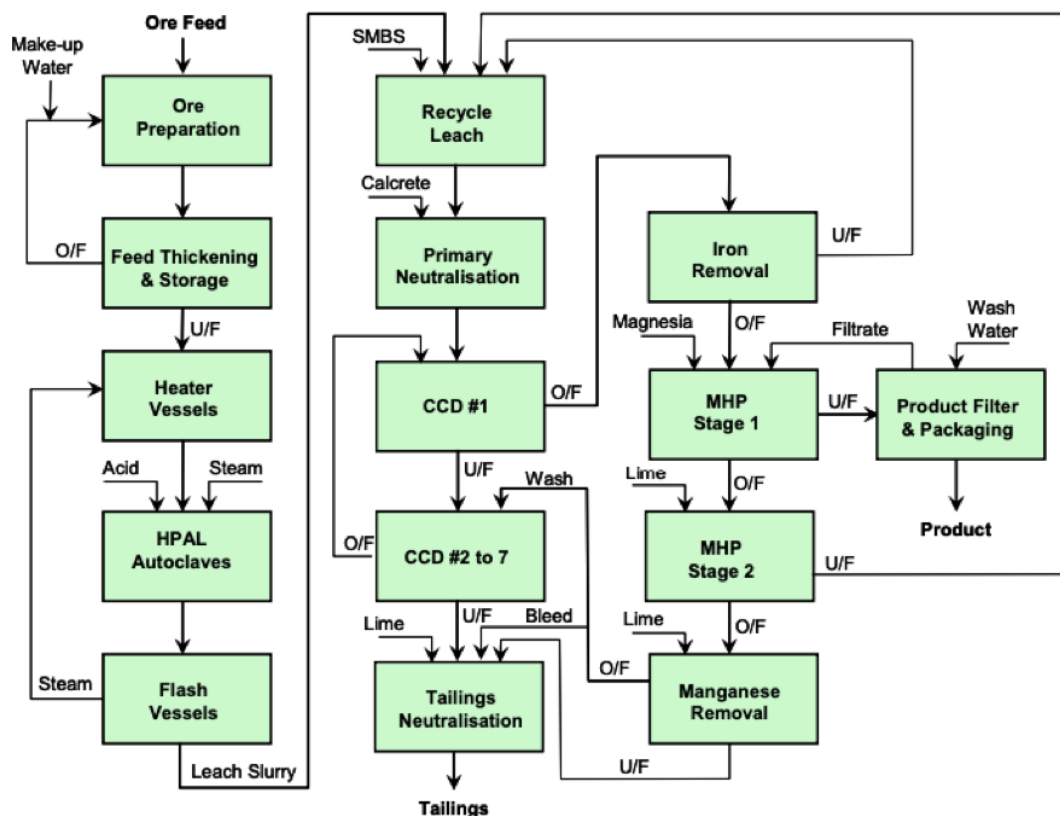

Figure 7 - Wingellina 2008 Phase 1 Feasibility Study Process Block Flow Diagram

3.4 CENTRAL MUSGRAVE PROJECT (CMP) (CONTINUED)

3.4.6. COMMENCEMENT OF DEFINITIVE FEASIBILITY STUDY

In early 2013 Metals X commenced definitive feasibility study (DFS) activities to advance the Wingellina deposit towards development and entered into a number of agreements, including a Memorandum of Understanding with Samsung C&T pertaining to a potential Project Management Contract and a Processing Study Management agreement with SNC-Lavalin Australia Pty Ltd.

In June 2013 the Board of Metals X made the decision to postpone the DFS activities due to the then depressed equity and resource markets and a cyclical low in nickel prices.

Despite postponing the DFS, Metals X continued advancing key issues such as environmental permitting, infill drilling of the high grade nickel-cobalt domains as potential high grade starter pits and testwork to produce nickel sulphate and cobalt sulphate products. As a result, the CMP has multiple development options and is well positioned for commencement of a detailed design phase subject to markets and funding.

3.4.7. CALCRETE RESOURCES - LEWIS CALCRETE PROJECT

In 2013 Exploration Licence E69/3065 located within WA, approximately 25km north-west of the Wingellina township (Figure 2) was acquired - known as the Lewis Calcrete Deposit.

The PSF1 had estimated a total of ~800,000t/year of calcrete/limestone would be required over the life of the CMP for acid neutralisation purposes.

Initial drill testing comprising 89 shallow reconnaissance 100 metre spaced RC holes along a 9km access track was completed in 2014 with 579 samples submitted for analysis. Test work subsequently confirmed good quality calcrete with CaO+MgO+LOI exceeding 70% confirmed in 68 of the holes drilled. The calcrete is calcium-rich, with MgO rarely exceeding 2%. The base of the calcrete profile was found to occur at a depth of about 6 metres below surface.

Resource definition drilling commenced in late 2020 with the planned program being approximately 50% completed. The program was postponed due to COVID restrictions and is anticipated that NICO will recommence this program once these restrictions have been lifted. When completed, the results from this program will be used to quantify and ascertain the continuity of the best quality calcrete in the deposit for HPAL process requirements. Additional calcrete deposits also occur elsewhere and on the tenement that may also be utilised as a source for haul road construction materials for the Projects.

3.4.8. ENVIRONMENTAL REQUIREMENTS AND APPROVALS

The CMP was referred to the Environmental Protection Authority (**EPA**) in September 2013 under section 38 (Part IV) of the *Environmental Protection Act 1986* (**EP Act**).

In November 2013 the EPA determined that the Projects required formal assessment under the EP Act and set a 'Public Environment Review' (PER) level of assessment with an eight-week public review period.

A PER is required for projects of regional and/or State-wide significance which raise a number of significant environmental factors or issues, some of which are considered complex and require detailed assessment. The EPA requires a formal public review, and compliance with the EP Act, to ensure that such proposals are implemented and managed in an environmentally acceptable manner.

The 'Environmental Scoping Document' (ESD) for the proposal was approved on 11 July 2014 and the PER document was released for public review from 14 September 2015 to 9 November 2015.

The report and recommendations of the EPA were returned on 15 June 2016 with the Minister for the Environment noting that the EPA has concluded that the Wingellina proposal may be implemented to meet the EPA's objectives, provided the implementation of the proposal is carried out in accordance with the recommended conditions as follows:

- (a) a requirement for a revised air quality management plan to minimise the impacts of atmospheric and particulate emissions; and
- (b) a requirement to minimise impacts to *Goodenia* sp. aff. *quasilibera* (a small herbaceous plant) at the species and population level (populations of this species have been located within the proposed Officer Basin water borefield area of L69/12 and have not been found to occur anywhere else on the Project tenements or within the geological units of the Musgraves and thus this requirement is of minimal concern).

The imposed conditions were accepted by Metals X and on 2 September 2016 Metals X received a signed Ministerial Statement (No. 1034) that the Wingellina Nickel Project proposal may be implemented.

A condition of the environmental approval is the requirement for Hinckley Range to submit annual reports on performance and compliance, which have been done and will continue to be done.

In August 2021 a request was submitted to the EPA to extend the authorised timeframe for the substantial commencement of the project by a further five years.

In addition to the extension of the EPA approval, Hinckley Range has requested that the EPA consider the removal of the condition associated with the *Goodenia sp. aff. quasilibera* from the Statement. Updated information regarding *Goodenia sp. aff. quasilibera* was sought and obtained by Hinckley Range in July 2021 which confirmed that three other collections of this species have been lodged with WA Herbarium demonstrating that the species is more broadly distributed than the Wingellina assessment showed. This information confirmed that this species has now been described as *Goodenia asteriscus* and has been assessed as a Priority 3 species, rather than Priority 1 as it was at the time of the EPA assessment. In consideration of the updated information about *Goodenia sp. aff. quasilibera*, Hinckley has requested that the EPA consider the removal of this condition from its statement.

3.4.9. ADDITIONAL PROCESSING AND METALLURGICAL OPTION STUDIES

While the PIFS contemplated an ore processing route of HPAL followed by metal precipitation to a mixed nickel-cobalt hydroxide product, subsequent investigations have been undertaken into other metallurgical options, including numerous product options, such as ammonia leach, oxide flotation and iron exchange.

Test work in 2012 showed that Di-(2-ethyl hexyl) phosphoric acid (DE2HPA) was a very effective extractant for scandium with excellent selectivity.

In 2012 precipitated test work using sodium hydrosulphide (NaHS) to produce a mixed nickel and cobalt sulphides product resulted in recoveries of approximately 90% nickel and 96% Cobalt into a product containing 47.6% nickel and 4.05% cobalt, with a sulphur to metal ratio of 1.16. In 2013 a mixed sulphide precipitate product was also achieved through using sulphide hydrogen gas which showed nickel recoveries in the ranged of 95.6 - 99.2% and cobalt in the ranged of 94.8 - 99.8%.

In late 2017 SGS Minerals Metallurgy was engaged to undertake sulphate crystallisation testwork (a product used in batteries) on Wingellina ores. The results of this work were positive and highlighted potential processing refinements warranting further investigation. Importantly, high quality nickel and cobalt sulphates as potential battery feedstock were produced as shown in photo 2 below.

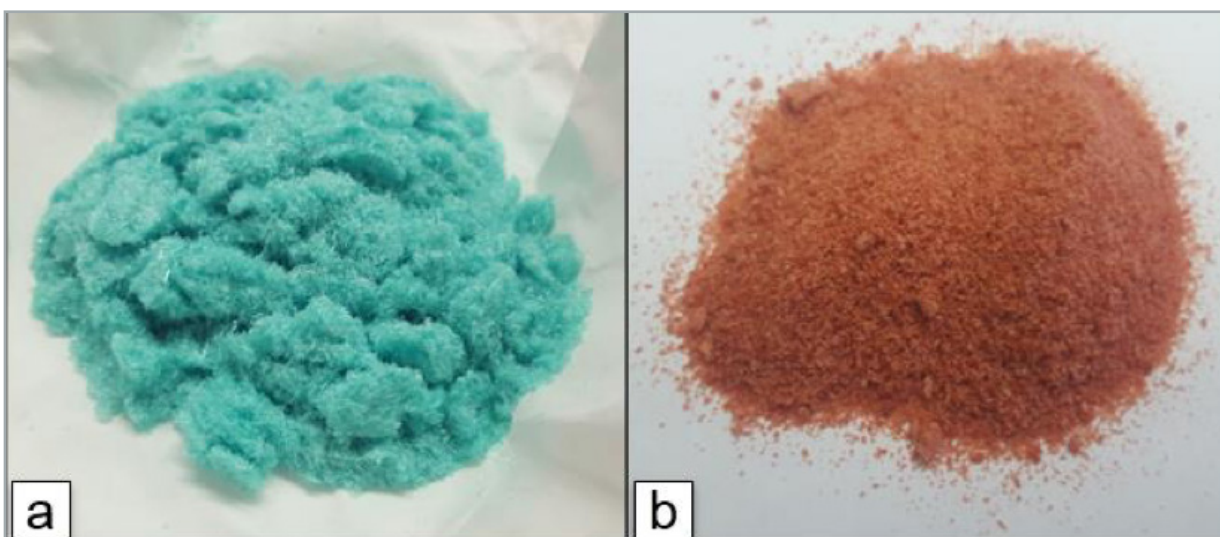

Photo 2 - (a) Nickel Sulphate (NiO_4S), and (b) Cobalt Sulphate (CoO_4S)

In addition, various programs of testwork on the physical properties have also been undertaken to determine the physical, chemical and geochemical characteristics of mine waste materials. In particular in 2014 testwork showed that all waste samples assessed were classed as non-acid forming (**NAF**) and the gabbro and saprock waste materials are physically, chemically and geochemically benign, and are likely to be a valuable source of competent surface armour material for use in rehabilitation of waste landforms.

3.4 CENTRAL MUSGRAVE PROJECT (CMP) (CONTINUED)

During 2012 Metals X used large diameter Bauer drilling (780mm) to collect 88 tonnes of Wingellina ore representing the first 10 years of ROM material and 5 tonnes of calcrete representing the potential acid neutralisation material. Testwork on the sample included ore characterisation (unconfined compressive strength (UCS), impact work index, abrasion index, bond rod mill index & bond ball mill index), HPAL and rheology. In addition, sub-samples were submitted for consolidation and shear tests, compression tests, wall friction tests and bulk density tests. Additional tests also included angle of repose and belt surcharge angles.

During 2014 a 120-tonne bulk sample of Wingellina ore at the average reserve grade with respect to nickel and cobalt was collected from a series of trenches and sent to POSCO in South Korea for pilot testing using POSCO's proprietary "PosNEP" technology. POSCO (formerly Pohang Iron and Steel Company) is a South Korean steel-making and metals research company. The PosNEP technology represents an alternative processing route for high iron, low magnesium nickel ores which produces a FeNi product (18% Ni). The PosNEP trials were successful with the additional benefits of using minimal water compared to other processes and the ability to recycle the main reagents.

3.4.10. MIXED SULPHIDES AS AN ALTERNATIVE TO MIXED HYDROXIDES

A mixed sulphide product was not considered in the 2008 PIFS; at the time of the PIFS it was considered that market preference was moving towards a mixed hydroxide product to avoid the production of sulphide waste.

In 2012 Jacobs (PKA Aker Solutions Australia Pty Ltd) was engaged to review the various process options including the production of a mixed sulphides product. The results of the study demonstrated that a mixed sulphide product is a viable alternative should the mixed hydroxide product be less attractive to the market.

The results of the study indicated that the mixed sulphide product option is likely to be more capital intensive than the mixed hydroxide product option. In addition, although there would be a reduction in operating costs for the mixed sulphide product (by eliminating magnesia and sodium metabisulfite (SMBS) and reducing transport costs) it would be offset by increased maintenance costs for the mixed sulphide product circuit, resulting in similar costs to the mixed hydroxide product option overall.

3.4.11. HIGH GRADE NICKEL AND COBALT START-UP OPTIONS - 2017

With the increasing cobalt price throughout 2017 (which peaked at US\$95,000/t in March 2018) Metals X undertook a review of the cobalt inventory of the Wingellina deposit with the aim of investigating higher-grade cobalt domains that could be targeted as a high-grade start-up option. This work resulted in the definition of high-grade cobalt deposits.

Past drilling and mining studies at Wingellina were focused predominantly on optimisation for nickel production. However, within the Wingellina Mineral Resource, which extends over almost 10km, Metals X delineated 15 possible high-grade cobalt-nickel pits which could be incorporated into a high grade start up scenario.

3.4.12. WINGELLINA EXPLORATION CAMP

The CMP is serviced by the exploration camp located upon E69/535 approximately 1.5km from the Wingellina community in Western Australia. The camp comprises a series of accommodation dongas and messing facilities able to house 22 persons, along with office, communications, power plant and workshop facilities.

3.5 BUSINESS STRATEGY/OBJECTIVES OF THE COMPANY

The Company's purpose is to increase shareholder wealth by exploring, developing, evaluating, acquiring, and exploiting mineral resource project opportunities

Following Admission, the Company's primary focus will be to continue to advance the CMP towards development. A review of all previous works and studies will be undertaken to identify any additional information or programmes required to undertake a comprehensive feasibility study update, including the exploitation of the resources, infrastructure requirements, approvals and local sources of calcrete and water.

Several exploration programs will be undertaken to determine how best to exploit the potential high-grade zones of nickel, cobalt and scandium as well as to better define the calcrete resource

A review all of the various mineral processing routes will also be undertaken in order to identify any additional metallurgical testwork to maximise the value of extraction of minerals from the Central Musgrave Project.

3.6 PROPOSED EXPLORATION AND OPERATIONAL ACTIVITIES BUDGETS

The Company proposes to fund its intended activities as outlined in the tables below from the proceeds of the Public Offer. It should be noted that the budgets will be subject to modification on an ongoing basis depending on the results obtained from the various studies and exploration programs undertaken. This will involve an ongoing assessment of the Company's Projects and commodity markets and may lead to increased or decreased levels of expenditure on certain interests, reflecting a change in emphasis. Subject to the above, the following budgets are proposed which takes into account the proposed expense over the next 2 years.

As budgeted below, the Company's exploration expenditures will exceed the expenditure requirements for each of the Tenements (see Schedule 2 for further details).

Activities	Minimum Subscription (\$10,00,000 raised)			Maximum Subscription (\$12,00,000 raised)		
	Year 1 (\$)	Year 2 (\$)	Total (\$)	Year 1 (\$)	Year 2 (\$)	Total (\$)
Feasibility studies	259,200	259,200	518,400	311,000	311,000	622,000
Drilling and assays	450,700	854,300	1,305,000	540,800	1,025,200	1,566,000
Contractors and consultants	556,100	532,000	1,088,000	611,700	585,200	1,196,900
Land access and Compensation	200,400	192,000	392,400	221,500	201,600	423,100
Permits, rents and rates	77,100	76,200	153,300	77,100	76,200	153,300
Supplies and other	300,300	340,000	640,300	320,300	364,000	684,300
Total	1,843,800	2,253,700	4,097,000	2,082,400	2,563,200	4,645,600

3.7 DIVIDEND POLICY

The Company does not expect to pay dividends in the near future as its focus will primarily be on exploration of the Projects and future acquisitions.

Any future determination as to the payment of dividends by the Company will be at the discretion of the Directors and will depend upon matters such as the availability of distributable earnings, the operating results and financial condition of the Company, future capital requirements, general business and other factors considered relevant by the Directors. No assurances are given in relation to the payment of dividends, or that any dividends may attach franking credits.

04. Risk Factors

As with any investment in securities, there are risks involved. This Section identifies the major areas of risk associated with an investment in the Company, but should not be taken as an exhaustive list of the potential risk factors to which the Company and its Security holders are exposed. Potential investors should read the entire Prospectus and consult their professional advisers before deciding whether to apply for Securities.

Any investment in the Company under this Prospectus should be considered highly speculative.

4.1 COMPANY SPECIFIC AND SIGNIFICANT RISKS

(a) Limited history

The Company was incorporated on 29 April 2021 and therefore has limited operational and financial history on which to evaluate its business and prospects. The prospects of the Company must be considered in light of the risks, expenses and difficulties frequently encountered by companies in the early stages of their development, particularly in the mineral exploration sector, which has a high level of inherent risk and uncertainty. No assurance can be given that the Company will achieve commercial viability through the successful exploration on, or mining development of, the Projects. Until the Company is able to realise value from the Projects, it is likely to incur operational losses.

(b) New projects and acquisitions

The Company will actively pursue and assess other new business opportunities in the resources sector. These new business opportunities may take the form of direct project acquisitions, joint ventures, farm-ins, acquisition of tenements/permits, and/or direct equity participation.

The acquisition of projects (whether completed or not) may require the payment of monies (as a deposit and/or exclusivity fee) after only limited due diligence or prior to the completion of comprehensive due diligence. There can be no guarantee that any proposed acquisition will be completed or be successful. If the proposed acquisition is not completed, monies advanced may not be recoverable, which may have a material adverse effect on the Company.

If an acquisition is completed, the Directors will need to reassess at that time, the funding allocated to current projects and new projects, which may result in the Company reallocating funds from the Projects and/or raising additional capital (if available). Furthermore, notwithstanding that an acquisition may proceed upon the completion of due diligence, the usual risks associated with the new project/business activities will remain.

(c) Future capital requirements

The Company has no operating revenue and is unlikely to generate any operating revenue unless and until the Projects are successfully developed and production commences. The future capital requirements of the Company will depend on many factors including its business development activities. The Company believes its available cash and the net proceeds of the Public Offer should be adequate to fund its business development activities, exploration program and other Company objectives in the short term as stated in this Prospectus.

In order to successfully develop the Projects and for production to commence, the Company will require further financing in the future, in addition to amounts raised pursuant to the Public Offer. Any additional equity financing may be dilutive to Shareholders, may be undertaken at lower prices than the then market price (or Public Offer Price) or may involve restrictive covenants which limit the Company's operations and business strategy. Debt financing, if available, may involve restrictions on financing and operating activities.

Although the Directors believe that additional capital can be obtained, no assurances can be made that appropriate capital or funding, if and when needed, will be available on terms favourable to the Company or at all. If the Company is unable to obtain additional financing as needed, it may be required to reduce the scope of its activities and this could have a material adverse effect on the Company's activities including resulting in the Tenements being subject to forfeiture, and could affect the Company's ability to continue as a going concern.

The Company may undertake additional offerings of Securities in the future. The increase in the number of Shares issued and outstanding and the possibility of sales of such shares may have a depressive effect on the price of Shares. In addition, as a result of such additional Shares, the voting power of the Company's existing Shareholders will be diluted.

(d) Title risks

- (i) One the Tenements comprising the Project, E69/535 located in WA, is nearing expiry and one of the Tenements, EL 5860 located in SA, has recently expired. Applications for renewal of these Tenements have been lodged with the relevant authorities, however no outcome has been received as at the Prospectus Date.
- (ii) The deposit hosting most of the Mineral Resources of the Wingellina Project is located within E69/535. E69/535 is due to expire on 22 December 2021 and is only eligible for renewal each year for a maximum period of 12 months upon application to the Minister under the Mining Act (WA). There is no guarantee that any renewal or extension will be granted this year or any subsequent year, however as the term of E69/535 has been renewed annually for several past years, the Company does not anticipate that E69/535 will not be renewed.
- (iii) Interests in all tenements in Western Australia and South Australia are governed by state legislation and are evidenced by the granting of licences or leases. Each licence or lease is for a specific term and carries with it annual expenditure and reporting commitments, as well as other conditions requiring compliance. Consequently, the Company could lose title to or its interest in the Tenements if licence conditions are not met or if insufficient funds are available to meet expenditure commitments.

(e) Exploration and development risks

Mineral exploration and development is a high-risk undertaking. There can be no assurance that exploration of the Projects or any other exploration properties that may be acquired in the future will result in the discovery of an economic resource.

Exploration in terrains with existing mineralisation endowments and known occurrences may slightly mitigate this risk. In respect of the Projects, the reliability of the data used to produce the Independent Geologists Report in this regard is limited as it is historical in nature.

Even if an apparently viable resource is identified, there is no guarantee that it can be economically exploited due to various issues including lack of ongoing funding, adverse government policy, geological conditions, commodity prices or other technical difficulties.

The future exploration activities of the Company may be affected by a range of factors including geological conditions, limitations on activities due to seasonal weather patterns, unanticipated operational and technical difficulties, industrial and environmental accidents, native title process, changing government regulations and many other factors beyond the control of the Company.

4.1 COMPANY SPECIFIC AND SIGNIFICANT RISKS (CONTINUED)

The success of the Company will also depend upon the Company having access to sufficient development capital, being able to maintain title to its projects and obtaining all required approvals for its activities. In the event that exploration programs are unsuccessful this could lead to a diminution in the value of its projects, a reduction in the cash reserves of the Company and possible relinquishment of part or all of its projects.

(f) COVID-19 risks to access

The onset of the COVID-19 pandemic has impacted travel to and within the CMP region and has been and remains limited in Western Australia under the Emergency Management Act 2005 (WA) - Remote Aboriginal Communities Directions (No. 3) to those providing essential services. Although there has been a roadmap prepared for these restrictions to be eased and repealed it is uncertain as to when this may occur. Although field personnel can travel to site they are confined to exploration camp at Wingellina under COVID-19 isolation protocol requirements.

On 10 July 2021 the Commonwealth repealed the previous restrictions to remote communities under the Biosecurity Act (Human Biosecurity Emergency) (Human Coronavirus with Pandemic Potential) (Emergency Requirements for Remote Communities) Determination 2020. However, there is no guarantee at this time if such an order could be reinstated.

The South Australian Government also advised on 10 July 2021 that restrictions would be lifted, however various restrictions into the APY lands (covering the SA Tenements) may remain in place outside of SA Government health and/or emergency directives and access permit procedures remain in place.

These restrictions will and may limit the type of exploration activities that can be undertaken and may delay various exploration programs to be undertaken.

(g) Operating risk

The operations of the Company may be affected by various factors, including failure to locate or identify mineral deposits, failure to achieve predicted grades in exploration and mining, operational and technical difficulties encountered in mining, difficulties in commissioning and operating plant and equipment, mechanical failure or plant breakdown, unanticipated metallurgical problems which may affect extraction costs, adverse weather conditions, industrial and environmental accidents, industrial disputes and unexpected shortages or increases in the costs of consumables, spare parts, plant and equipment.

No assurances can be given that the Company will achieve commercial viability through the successful exploration and/or mining of its projects. Unless and until the Company is able to realise value from its projects, it is likely to incur ongoing operating losses.

(h) Metallurgy

Metal and/or mineral recoveries are dependent upon the metallurgical process that is required to liberate economic minerals and produce a saleable product and by nature contain elements of significant risk such as:

- (i) identifying a metallurgical process through test work to produce a saleable metal and/or concentrate;
 - (ii) developing an economic process route to produce a metal and/or concentrate; and
 - (iii) changes in mineralogy in the ore deposit can result in inconsistent metal recovery, affecting the economic viability of the project.
- (i) Metals and currency price volatility

The Company's ability to proceed with the development of its projects and benefit from any future mining operations will depend on market factors, some of which may be beyond its control. It is anticipated that any revenues derived from mining will primarily be derived from the sale of nickel and cobalt. Consequently, any future earnings are likely to be closely related to the price of nickel and cobalt and the terms of any off-take agreements that the Company enters into.

The world market for minerals is subject to many variables and may fluctuate markedly. These variables include world demand for nickel and cobalt that may be mined commercially in the future from the Company's project areas, forward selling by producers and production cost levels in major mineral-producing regions. Mineral prices are also affected by macroeconomic factors such as general global economic conditions and expectations regarding inflation and interest rates. These factors may have an adverse effect on the Company's exploration, development and production activities, as well as on its ability to fund those activities.

Metals are principally sold throughout the world in US dollars. The Company's cost base will be payable in various currencies including Australian dollars and US dollars. As a result, any significant and/or sustained fluctuations in the exchange rate between the Australian dollar and the US dollar could have a materially adverse effect on the Company's operations, financial position (including revenue and profitability) and performance. The Company may undertake measures, where deemed necessary by the Board to mitigate such risks.

(j) Aboriginal heritage risk

Aboriginal heritage sites and objects are protected by law. The Company must ensure that the conduct of exploration and mining operations on any of the Tenements does not damage, disturb or interfere with any Aboriginal site and object.

There are a number of registered and non-registered sites of Aboriginal heritage or significance located on the Tenements (refer section 6 and Schedule 4 of the Solicitors' Report in Schedule 2 of this Prospectus for details of registered sites).

There remains a risk that additional Aboriginal sites may exist on the land the subject of the Tenements. The existence of such sites may preclude or limit exploration activities and any future mining activities in certain areas of the Tenements.

(k) Native title risks

The Company is aware that there are two positive native title determinations and two registered native title within the area covered by the Tenements (refer to section 7.3 and Schedule 3 of the Solicitors' Report in Schedule 2 of this Prospectus for details).

There remains a risk that in the future, native title and/or registered native title claims may affect the land the subject of the Tenements or in the vicinity.

The existence of native title claims over the area covered by the Tenements, or a subsequent determination of native title over the area, will not impact the rights or interests of the holder under the Tenements provided the Tenements have been validly granted in accordance with the Native Title Act.

However, if any Tenement was not validly granted in compliance with the Native Title Act, this may have an adverse impact on the Company's activities. The Company is not aware that any of the Tenements were not validly granted in accordance with the Native Title Act.

The grant of any future tenure to the Company over areas that are covered by registered claims or determinations will likely require engagement with the relevant claimants or native title holders (as relevant) in accordance with the Native Title Act.

(l) Aboriginal land rights over SA Tenements

The Tenements in South Australia are situated on lands belonging to the Anangu Pitjantjatjara Yankunytjatjara (APY), the body corporate constituted under this name by the *Anangu Pitjantjatjara Yankunytjatjara Land Rights Act 1981 (SA)*.

The APY is the registered holder in fee simple of a large area of land situated in far northwest South Australia and is responsible for the management, use and control of the APY lands.

Works on the APY lands can only be commenced with the consent of the APY and the consent of the APY may be given subject to such conditions as the APY thinks fit, including the completion of heritage impact assessments by the APY and entering into agreements governing activities. In the case of the SA Tenements, access to the APY lands and the conduct of exploration, mining and associated activities on the APY lands is subject to the terms and conditions set out in two separate deeds of exploration (**Exploration Deeds**).

The Exploration Deeds set out the terms and process for access and conduct of exploration activities on the SA Tenements as well as annual payments to be made to the APY. Mining is not permitted under the Exploration Deeds, however they do set out a process regarding the preparation of mining proposals and mining agreements. Refer to section 8 and Schedules 3 and 5 of the Solicitors' Report in Schedule 2 of this Prospectus for further details).

The conduct of future development and mining operations on the SA Tenements will depend on the Company reaching agreement with the APY.

No assurance can be given that the Company will be able to reach agreement with the APY respect of any development or mining proposal within any particular time frame.

4.1 COMPANY SPECIFIC AND SIGNIFICANT RISKS (CONTINUED)

(m) Environmental risk

The operations and proposed activities of the Company are subject to state and federal laws and regulations concerning the environment. As with most exploration projects and mining operations, the Company's activities are expected to have an impact on the environment, particularly if advanced exploration or field development proceeds. It is the Company's intention to conduct its activities to the highest standard of environmental obligation, including compliance with all environmental laws.

The cost and complexity of complying with the applicable environmental laws and regulations may prevent the Company from being able to develop potentially economically viable mineral deposits.

Although the Company believes that it is in compliant in all material respects with all applicable environmental laws and regulations, there are certain risks inherent to its activities, such as accidental spills, leakages or other unforeseen circumstances, which could subject the Company to extensive liability.

Government authorities may, from time to time, review the environmental bonds that are placed on permits. The Directors are not in a position to state whether a review is imminent or whether the outcome of such a review would be detrimental to the funding needs of the Company.

Further, the Company may require approval from the relevant authorities before it can undertake activities that are likely to impact the environment. Failure to obtain such approvals will prevent the Company from undertaking its desired activities. The Company is unable to predict the effect of additional environmental laws and regulations, which may be adopted in the future, including whether any such laws or regulations would materially increase the Company's cost of doing business or affect its operations in any area.

There can be no assurances that new environmental laws, regulations or stricter enforcement policies, once implemented, will not oblige the Company to incur significant expenses and undertake significant investments in such respect which could have a material adverse effect on the Company's business, financial condition and results of operations.

(n) Metals and currency price volatility

The Company's ability to proceed with the development of its projects and benefit from any future mining operations will depend on market factors, some of which may be beyond its control. It is anticipated that any revenues derived from mining will primarily be derived from the sale of nickel and cobalt. Consequently, any future earnings are likely to be closely related to the price of nickel and cobalt and the terms of any off-take agreements that the Company enters into.

The world market for minerals is subject to many variables and may fluctuate markedly. These variables include world demand for nickel and cobalt that may be mined commercially in the future from the Company's project areas, forward selling by producers and production cost levels in major mineral-producing regions. Mineral prices are also affected by macroeconomic factors such as general global economic conditions and expectations regarding inflation and interest rates. These factors may have an adverse effect on the Company's exploration, development and production activities, as well as on its ability to fund those activities.

Metals are principally sold throughout the world in US dollars. The Company's cost base will be payable in various currencies including Australian dollars and US dollars. As a result, any significant and/or sustained fluctuations in the exchange rate between the Australian dollar and the US dollar could have a materially adverse effect on the Company's operations, financial position (including revenue and profitability) and performance. The Company may undertake measures, where deemed necessary by the Board to mitigate such risks.

(o) Infectious diseases

The outbreak of the coronavirus disease (COVID-19) is having a material effect on global economic markets. The global economic outlook is facing uncertainty due to the pandemic, which has had and may continue to have a significant impact on capital markets.

The Company's Share price may be adversely affected by the economic uncertainty caused by COVID-19.

Further measures to limit the transmission of the virus implemented by governments around the world (such as travel bans and quarantining) may adversely impact the ability of the Company to undertake operations.

4.2 GENERAL MINING INDUSTRY RISKS

(a) Payment obligations

Pursuant to the Tenements comprising the Projects, the Company will become subject to payment and other obligations. In particular, holders are required to expend the funds necessary to meet the minimum work commitments attaching to the Tenements. Failure to meet these work commitments may render the Tenements subject to forfeiture or result in the holders being liable for fees. Further, if any contractual obligations are not complied with when due, in addition to any other remedies that may be available to other parties, this could result in dilution or forfeiture of the Company's interest in the Projects. Further details of these conditions and obligations are set out in section 6.1 in the Solicitors' Report.

(b) Competition risk

The industry in which the Company will be involved is subject to domestic and global competition, including major mineral exploration and production companies. Although the Company will undertake all reasonable due diligence in its business decisions and operations, the Company will have no influence or control over the activities or actions of its competitors, which activities or actions may, positively or negatively, affect the operating and financial performance of the Company's projects and business.

Some of the Company's competitors have greater financial and other resources than the Company and, as a result, may be in a better position to compete for future business opportunities. Many of the Company's competitors not only explore for and produce minerals, but also carry out refining operations and other products on a worldwide basis. There can be no assurance that the Company can compete effectively with these companies.

(c) Licences, permits and approvals

The Company holds (legally and/or beneficially) the exploration licences and applications set out in Schedule 1 of the Solicitors' Report. However, many of the mineral rights and interests to be held by the Company are subject to the need for ongoing or new government approvals, licences and permits. These requirements, including work permits and environmental approvals, will change as the Company's operations develop. Delays in obtaining, or the inability to obtain, required authorisations may significantly impact on the Company's operations.

(d) Reliance on key personnel

The Company is reliant on a number of key personnel and consultants, including members of the Board. The loss of one or more of these key contributors could have an adverse impact on the business of the Company.

It may be particularly difficult for the Company to attract and retain suitably qualified and experienced people given the current high demand in the industry and relatively small size of the Company, compared with other industry participants.

(e) Conflicts of interest

Certain Directors are also directors and officers of other companies engaged in mineral exploration and development and mineral property acquisitions. Accordingly, mineral exploration opportunities or prospects of which these Directors become aware may not necessarily be made available to the Company in first instance. Although these Directors have been advised of their fiduciary duties to the situations could arise in which their obligations to, or interests in, Company, there exist actual and potential conflicts of interest among these persons and other companies could detract from their efforts on behalf of the Company.

4.3 GENERAL INVESTMENT RISKS

(a) Economic risks

General economic conditions, movements in interest and inflation rates, the prevailing global commodity prices and currency exchange rates may have an adverse effect on the Company's exploration, development and production activities, as well as on its ability to fund those activities.

As with any exploration or mining project, the economics are sensitive to metal and commodity prices. Commodity prices fluctuate and are affected by many factors beyond the control of the Company. Such factors include supply and demand fluctuations for minerals, technological advances, forward selling activities and other macro-economic factors. These prices may fluctuate to a level where the proposed mining operations are not profitable. Should the Company achieve success leading to mineral production, the revenue it will derive through the sale of commodities also exposes potential income of the Company to commodity price and exchange rate risks.

(b) Market conditions

The market price of the Shares can fall as well as rise and may be subject to varied and unpredictable influences on the market for equities in general and resource exploration stocks in particular.

Further, share market conditions may affect the value of the Company's quoted Shares regardless of the Company's operating performance. Share market conditions are affected by many factors such as:

- (i) general economic outlook;
- (ii) interest rates and inflation rates;
- (iii) currency fluctuations;
- (iv) changes in investor sentiment;
- (v) the demand for, and supply of, capital; and
- (vi) terrorism or other hostilities.

Neither the Company nor the Directors warrant the future performance of the Company or any return on an investment in the Company.

(c) Force majeure

The Company's projects now or in the future may be adversely affected by risks outside the control of the Company including labour unrest, subversive activities or sabotage, fires, floods, explosions or other catastrophes.

(d) Government and legal risk

Changes in government, monetary policies, taxation and other laws can have a significant impact on the Company's assets, operations and ultimately the financial performance of the Company and its Shares. Such changes are likely to be beyond the control of the Company and may affect industry profitability as well as the Company's capacity to explore and mine.

The Company is not aware of any reviews or changes that would affect the Projects. However, changes in community attitudes on matters such as taxation, competition policy and environmental issues may bring about reviews and possibly changes in government policies. There is a risk that such changes may affect the Company's development plans or its rights and obligations in respect of its projects. Any such government action may also require increased capital or operating expenditures and could prevent or delay certain operations by the Company.

(e) Litigation risks

The Company is exposed to possible litigation risks including native title claims, tenure disputes, environmental claims, occupational health and safety claims and employee claims. Further, the Company may be involved in disputes with other parties in the future which may result in litigation. Any such claim or dispute if proven, may impact adversely on the Company's operations, financial performance and financial position. The Company is not currently engaged in any litigation.

(f) Insurance risks

The Company intends to insure its operations in accordance with industry practice. However, in certain circumstances, the Company's insurance may not be of a nature or level to provide adequate insurance cover. The occurrence of an event that is not covered or fully covered by insurance could have a material adverse effect on the business, financial condition and results of the Company. Insurance against all risks associated with mining exploration and production is not always available and where available the costs can be prohibitive.

(g) Taxation

The acquisition and disposal of Securities will have tax consequences, which will differ depending on the individual financial affairs of each investor. All potential investors in the Company are urged to obtain independent financial advice about the consequences of acquiring Securities from a taxation point of view and generally.

To the maximum extent permitted by law, the Company, its officers and each of their respective advisers accept no liability and responsibility with respect to the taxation consequences of applying for Shares offered under this Prospectus.

(h) Climate change risks

Climate change is a risk the Company has considered, particularly related to its operations in the mining industry. The climate change risks particularly attributable to the Company include:

- (i) the emergence of new or expanded regulations associated with the transitioning to a lower-carbon economy and market changes related to climate change mitigation. The Company may be impacted by changes to local or international compliance regulations related to climate change mitigation efforts, or by specific taxation or penalties for carbon emissions or environmental damage. These examples sit amongst an array of possible restraints on industry that may further impact the Company and its profitability. While the Company will endeavour to manage these risks and limit any consequential impacts, there can be no guarantee that the Company will not be impacted by these occurrences; and
- (ii) climate change may cause certain physical and environmental risks that cannot be predicted by the Company, including events such as increased severity of weather patterns and incidence of extreme weather events and longer term physical risks such as shifting climate patterns. All these risks associated with climate change may significantly change the industry in which the Company operates.

4.4 Speculative investment

The above list of risk factors ought not to be taken as exhaustive of the risks faced by the Company or by investors in the Company. The above factors, and others not specifically referred to above, may in the future materially affect the financial performance of the Company and the value of the Securities offered under this Prospectus.

Therefore, the Securities to be issued pursuant to this Prospectus carry no guarantee with respect to the payment of dividends, returns of capital or the market value of those Securities.

Potential investors should consider that the investment in the Company is highly speculative and should consult their professional advisers before deciding whether to apply for Securities pursuant to this Prospectus.

05. Financial Information

5.1 FINANCIAL INFORMATION

This Section 5 sets out:

- (a) the audited historical Statements of Profit or Loss and Other Comprehensive Income and Statement of Cash flows for the years ended 30 June 2019, 30 June 2020 and 30 June 2021 for Metals Exploration Pty Ltd and 30 June 2021 for NICO Resources Limited; and
- (b) the audited historical Statement of Financial Position for the years ended 30 June 2019, 30 June 2020 and 30 June 2021 for Metals Exploration Pty Ltd and 30 June 2021 for NICO Resources Limited, (together, the **Historical Financial Information**), and
- (c) the pro forma historical Statement of Financial Position as at 30 June 2021, (collectively referred to as the **Financial Information**).

The Directors are responsible for the preparation and inclusion of the Financial Information in the Prospectus. Criterion Audit Pty Ltd has prepared an Investigating Accountant's Report in respect of the Financial Information. A copy of this report, which includes an explanation of the scope and limitations of the Investigating Accountant's work, is set out in Schedule 1.

Investors are urged to read the Investigating Accountant's Report in full.

5.2 FORECAST FINANCIAL INFORMATION

There are significant uncertainties associated with forecasting future revenues and expenses of the Company. In light of uncertainty as to timing and outcome of the Company's growth strategies and the general nature of the industry in which the Company will operate, as well as uncertain macro market and economic conditions in the Company's markets, the Company's performance in any future period cannot be reliably estimated. On these bases and after considering ASIC Regulatory Guide 170, the Directors do not believe they have a reasonable basis to reliably forecast future earnings and accordingly forecast financials are not included in this Prospectus.

5.3 HISTORICAL AND PRO FORMA FINANCIAL STATEMENTS

Statement of Comprehensive Income

METALS EXPLORATION PTY LTD

	Audited 30-Jun-2021 \$	Audited 30-Jun-2020 \$	Audited 30-Jun-2019 \$
Revenue	5,937	3,738	3,398
Corporate expenses	(1,355)	(884)	(1,513)
Depreciation expenses	(30,978)	(34,844)	(56,851)
Loan forgiveness	806,689	805,624	2,924,709
Profit/(loss) before tax	780,293	773,634	2,869,743
Income tax benefit/(expense)	7,919	9,598	16,490
Net profit/(loss)for the year from operations	788,212	783,232	2,886,233
Other comprehensive income	-	-	-
Total comprehensive profit/(loss)for the year	788,212	783,232	2,886,233

NICO RESOURCES LIMITED

	Audited 30-Jun-2021 \$
Revenue	-
Administrative expenses	(1,000)
Corporate compliance expenses	(24,505)
Profit/(loss) before tax	(25,505)
Income tax benefit/(expense)	-
Net profit/(loss)for the year from operations	(25,505)
Other comprehensive income	-
Total comprehensive profit/(loss)for the year	(25,505)

Statement of Financial Position

	Audited Metals Exp 30 June 19 A\$	Audited Metals Exp 30 June 20 A\$	Audited Metals Exp 30 June 21 A\$	Audited NICO 30 June 21 A\$	Acquisition Metals Exp A\$	Reverse Acquisition Metals Exp A\$	NICO Consolidated Prior to IPO A\$	Min Adjustments 30 June 21 A\$	Max Adjustments 30 June 21 A\$	Min Pro-Forma Post Acquisition 30 June 2021 A\$	Max Pro-Forma Post Acquisition 30 June 2021 A\$
ASSETS											
Current Assets											
Cash and cash equivalents	80,370	36,105	20,183	67,502	-	-	87,685	9,361,099	11,226,684	9,448,784	11,314,369
Trade and other receivables	52,384	27,001	33,684	2,550	-	-	36,234			36,234	36,234
Inventories	40,839	24,936	28,701		-	-	28,701			28,701	28,701
Total Current Assets	173,593	88,042	82,568	70,052	-	-	152,620	9,361,099	11,226,684	9,513,719	11,379,304
Non-Current Assets											
Plant and equipment	129,891	102,497	93,911	-	-	-	93,911	-	-	93,911	93,911
Deferred tax assets	36,785	-	57,573				57,573			57,573	57,573
Investments	-	-	-	-	7,314,715	(7,314,715)	-	-	-	-	-
Exploration & evaluation expenditure	2,051,141	3,384,007	4,471,191	-	-	-	4,471,191	-	-	4,471,191	4,471,191
Total Non-Current Assets	2,217,817	3,486,504	4,622,675	-	7,314,715	(7,314,715)	4,622,675	-	-	4,622,675	4,622,675
Total Assets	2,391,410	3,574,546	4,705,243	70,052	7,314,715	(7,314,715)	4,775,295	9,361,099	11,226,684	14,136,394	16,001,979
LIABILITIES											
Current Liabilities											
Trade and other payables	51,769	83,367	27,640	28,055	-	-	55,695	-	-	55,695	55,695
Total Current Liabilities	51,769	83,367	27,640	28,055	-	-	55,695	-	-	55,695	55,695

Statement of Financial Position

	Audited Metals Exp 30 June 19 A\$	Audited Metals Exp 30 June 20 A\$	Audited Metals Exp 30 June 21 A\$	Audited NICO 30 June 21 A\$	Acquisition Metals Exp A\$	Reverse Acquisition Metals Exp A\$	NICO Consolidated Prior to IPO A\$	Min Adjustments 30 June 21 A\$	Max Adjustments 30 June 21 A\$	Min Pro-Forma Post Acquisition 30 June 2021 A\$	Max Pro-Forma Post Acquisition 30 June 2021 A\$
Non-Current Liabilities											
Provisions	15,000	15,000	15,000	-	-	-	15,000	-	-	15,000	15,000
Deferred Tax Liabilities	583,822	952,128	1,350,340	-	-	-	1,350,340	-	-	1,350,340	1,350,340
Total Non -Current Liabilities	598,822	967,128	1,365,340	-	-	-	1,365,340	-	-	1,365,340	1,365,340
Total Liabilities	650,591	1,050,495	1,392,980	-	-	-	1,421,035	-	-	1,421,035	1,421,035
Net Assets	1,740,819	2,524,051	3,312,263	41,997	7,314,715	(7,314,715)	3,354,260	9,361,099	11,226,684	12,715,359	14,580,944
EQUITY											
Contributed equity	21,701,750	21,701,750	21,701,750	67,502	5,000,000	(450,002)	26,319,250	9,387,519	11,253,103	35,706,769	37,572,354
Reserves	-	-	-	-	2,314,715	-	2,314,175	140,947	140,947	2,455,663	2,455,663
Accumulated losses	(19,960,931)	(19,177,699)	(18,389,487)	(25,505)	-	(6,864,713)	(25,279,705)	(167,367)	(167,366)	(25,447,072)	(25,447,072)
Total Equity	1,740,819	2,524,051	3,312,263	41,997	7,314,715	(7,314,715)	3,354,260	9,361,099	11,226,684	12,715,359	14,580,944

Statement of Cashflows

METALS EXPLORATION PTY LTD

	Audited 30-Jun-2021 \$	Audited 30-Jun-2020 \$	Audited 30-Jun-2019 \$
Cash flows from operating activities			
Payments to suppliers and employees	(1,355)	(884)	(1,513)
Proceeds from receipt of interest	30	742	652
Payment for exploration and evaluation assets	5,907	2,996	2,746
Net cash provided from operating activities	4,582	2,854	1,885
Cash flows from investing activities			
Acquisition of Fixed Assets	(22,392)	(7,450)	(41,993)
Acquisition of Exploration Assets	(78,492)	(115,929)	(93,998)
Acquisition Mine Properties & Developments	(1,008,694)	(1,216,936)	(1,051,776)
Net cash (used in) investing activities	(1,109,578)	(1,340,315)	(1,187,767)
Cash flows from financing activities			
Proceeds from Borrowings	1,089,074	1,293,196	1,216,407
Net cash provided from financing activities	1,089,074	1,293,196	1,216,407
Net increase/(decrease) in cash held	(15,922)	(44,265)	30,525
Cash and cash equivalents at beginning of the year	36,105	80,370	49,845
Cash and cash equivalents at year end	20,183	36,105	80,370

NICO RESOURCES LIMITED

	Audited 30-Jun-2021 \$
Cash flows from operating activities	
Payments to suppliers and employees	-
Net cash provided from operating activities	-
Cash flows from investing activities	
Acquisition of Fixed Assets	-
Net cash (used in) investing activities	-
Cash flows from financing activities	
Proceeds from issue of shares in the Company	67,500
Net cash provided from financing activities	67,500
Net increase/(decrease) in cash held	67,500
Cash and cash equivalents at beginning of the year	-
Cash and cash equivalents at year end	67,500

Pro Forma Adjustments

	Minimum Raise \$	Maximum Raise \$
Cash & Cash Equivalents		
@ 30-Jun-2021 Metals Exploration Pty Ltd	20,183	20,183
@ 30-Jun-2021 Nico Resources Limited	67,502	67,502
Seed share issue: 1,650,000 @ \$0.05	82,500	82,500
Seed share issue: 3,000,000 @ \$0.10	300,000	300,000
IPO share issue: 30,000,000 or 40,000,000 @ \$0.20	6,000,000	8,000,000
IPO share issue to Metals X: 20,000,000 @\$0.20	4,000,000	4,000,000
Offer costs	(928,058)	(1,062,473)
Subsequent use of funds	(93,343)	(93,343)
Pro forma balance	9,448,784	11,314,369
Investments		
Project acquisition: 25,000,000 shares @ \$0.20	5,000,000	5,000,000
Project acquisition: 25,000,000 options @ 9.2589 cents valued under Black-Scholes	2,314,715	2,314,715
Reverse Acquisition entry	(7,314,715)	(7,314,715)
Pro forma balance	-	-
Exploration & Evaluation Expenditure		
@ 30-Jun-21 Metals Exploration Pty Ltd	4,471,191	4,471,191
Pro forma balance	4,471,191	4,471,191
Issued Capital		
@ 30-Jun-21 Metals Exploration Pty Ltd	21,701,750	21,701,750
@ 30-Jun-21 Nico Resources Limited	67,502	67,502
Seed share issue: 1,650,000 @ \$0.05	82,500	82,500
Seed share issue: 3,000,000 @ \$0.10	300,000	300,000
IPO share issue: 30,000,000 or 40,000,000 @ \$0.20	6,000,000	8,000,000
IPO share issue to Metals X: 20,000,000 @\$0.20	4,000,000	4,000,000
Offer costs	(928,058)	(1,062,473)
Project acquisition: 25,000,000 shares @ \$0.20	5,000,000	5,000,000
Reverse acquisition entry	(450,002)	(450,002)
Lead Manager options: 800,000 @ 8.3654 cents valued under Black-Scholes	(66,923)	(66,923)
Pro forma balance	35,706,769	37,572,354

Pro Forma Adjustments

	Minimum Raise \$	Maximum Raise \$
Reserves		
@ 30-Jun-21	-	-
Company acquisition: 25,000,000 options @ 9.2589 cents valued under Black-Scholes	2,314,715	2,314,715
Director options: 9,000,000 @ 8.225cents valued under Black-Scholes	74,024	74,024
Lead Manager options: 800,000 @ 8.3654 cents valued under Black-Scholes	66,923	66,923
Pro forma balance	2,455,663	2,455,663
Accumulated Losses		
@ 30-Jun-21 Metals Exploration Pty Ltd	(18,389,487)	(18,389,487)
@ 30-Jun-21 Nico Resources Limited	(25,505)	(25,505)
Subsequent use of funds	(93,343)	(93,343)
Director options: 9,000,000 @ 8.225cents valued under Black-Scholes	(74,024)	(74,024)
Reverse Acquisition: Corporate Restructure Costs	(6,983,562)	(6,983,562)
Reverse Acquisition entry	118,849	118,849
Pro forma balance	(25,447,072)	(25,447,072)

Options

Director Options

Underlying value of the security	\$0.05
Exercise price	\$0.25
Valuation date	29/7/2021
Expiry date	3 years from grant date
Life of Options in years	
Volatility	80.00%
Risk free rate	0.08%
Number of Options	9,000,000
Valuation per Option	8.225 cents

Metals X Options

Underlying value of the security	\$0.20
Exercise price	\$0.25
Valuation date	3/11/2021
Expiry date	3 years from grant date
Life of Options in years	
Volatility	80.00%
Risk free rate	0.08%
Number of Options	25,000,000
Valuation per Option	9.2589 cents

Lead Manager Options

Underlying value of the security	\$0.20
Exercise price	\$0.30
Valuation date	03/11/2021
Expiry date	3 years from ASX listing date
Life of Options in years	
Volatility	80.00%
Risk free rate	0.08%
Number of Options	800,000
Valuation per Option	8.3654 cents

Notes to the Financial Statements

NOTE 1: SUMMARY OF SIGNIFICANT ACCOUNTING POLICIES

BASIS OF PREPARATION

The historical financial information has been prepared in accordance with the recognition and measurement requirements of Australian Accounting Standards and the accounting policies adopted by the Company as detailed below. The pro forma financial information has been derived from the historical financial information and assumes the completion of the pro forma adjustments as set out above as if those adjustments had occurred as at 30 June 2021.

The financial information contained in this section of the Prospectus is presented in an abbreviated form and does not contain all the disclosures that are provided in a financial report prepared in accordance with the Corporations Act and Australian Accounting Standards and Interpretations.

GOING CONCERN

The financial information has been prepared on the going concern basis, which contemplates continuity of normal business activities and the realisation of assets and settlement of liabilities in the ordinary course of business. The ability of the Company to continue to pay its debts as and when they fall due is principally dependent upon the Company successfully raising additional share capital and the successful listing of the Company on the ASX. These conditions indicate a material uncertainty that may cast significant doubt about the ability of the Company to continue as a going concern. The Directors have prepared a cash flow forecast, which indicates that the Company will have sufficient cash flows to meet all commitments and working capital requirements for the 24-month period from the date of the prospectus. Based on the cash flow forecasts and other factors referred to above, the Directors are satisfied that the going concern basis of preparation is appropriate.

CURRENT AND NON-CURRENT CLASSIFICATION

Assets and liabilities are presented in the statement of financial position based on current and non-current classification. An asset is classified as current when: it is either expected to be realised or intended to be sold or consumed in normal operating cycle; it is held primarily for the purpose of trading; it is expected to be realised within 12 months after the reporting period; or the asset is cash or cash equivalent unless restricted from being exchanged or used to settle a liability for at least 12 months after the reporting period. All other assets are classified as non-current. A liability is classified as current when: it is either expected to be settled in normal operating cycle; it is held primarily for the purpose of trading; it is due to be settled within 12 months after the reporting period; or there is no unconditional right to defer the settlement of the liability for at least 12 months after the reporting period. All other liabilities are classified as non-current. Deferred tax assets and liabilities are always classified as non-current.

COMPARATIVES

When required by Accounting Standards, comparative figures have been adjusted to conform to changes in presentation for the current financial year.

SIGNIFICANT MANAGEMENT JUDGEMENT IN APPLYING ACCOUNTING POLICIES AND ESTIMATE UNCERTAINTY

When preparing the financial statements, management undertakes a number of judgements, estimates and assumptions about recognition and measurement of assets, liabilities, income and expenses. The actual results may differ from the judgements, estimates and assumptions made by management, and will seldom equal the estimated results. Information about significant judgements, estimates and assumptions that have the most significant effect on recognition and measurement of assets, liabilities, income and expense is provided below:

Exploration and evaluation expenditure

The application of the Company's accounting policy for exploration and evaluation expenditure requires judgement in determining whether it is likely that future economic benefits are likely either from future exploitation or sale or where activities have not reached a stage which permits a reasonable assessment of the existence of reserves.

Provision for rehabilitation

Environmental obligations associated with the retirement or disposal of mining properties and/or of exploration activities are recognised when the disturbance occurs and are based on the extent of the damage incurred. The provision is measured as the present value of the future expenditure. The rehabilitation liability is remeasured at each reporting period in line with the change in the time value of money (recognised as an interest expense in the statement of comprehensive income and an increase in the provision), and additional disturbances/change in the rehabilitation cost are recognised as additions/changes to the corresponding asset and rehabilitation liability

Income tax

The consolidated entity is subject to income taxes in the jurisdictions in which it operates. Significant judgement is required in determining the provision for income tax. There are many transactions and calculations undertaken during the ordinary course of business for which the ultimate tax determination is uncertain. The consolidated entity recognises liabilities for anticipated tax audit issues based on the consolidated entity's current understanding of the tax law. Where the final tax outcome of these matters is different from the carrying amounts, such differences will impact the current and deferred tax provisions in the period in which such determination is made.

Recovery of deferred tax assets

Deferred tax assets are recognised for deductible temporary differences only if the consolidated entity considers it is probable that future taxable amounts will be available to utilise those temporary differences and losses.

INCOME TAX

Current income tax assets and liabilities for the current and prior years are measured at the amount expected to be recovered from or paid to the taxation authorities. The tax rates and tax laws used to compute the amount are those that are enacted or substantively enacted by the reporting date. Deferred income tax is provided on all temporary differences at the reporting date between the tax bases of assets and liabilities and their carrying amounts for financial reporting purposes. Deferred income tax assets and liabilities are recognised for all taxable temporary differences:

- (a) except for the deferred income tax liability arises from the initial recognition of an asset or liability in a transaction that is not a business combination and at the time of the transaction affects neither the accounting profit nor taxable profit or loss; and
- (b) in respect of taxable temporary differences associated with investments in subsidiaries, associates and interests in joint ventures except where the timing of the reversal of the temporary differences can be controlled and it is probable that the temporary differences will not reverse in the foreseeable future.

The carrying amount of deferred income tax assets is reviewed at each reporting date and reduced to the extent that it is no longer probable that sufficient taxable profit will be available to allow all or part of the deferred income tax asset to be utilised. Unrecognised deferred income tax assets are reassessed at each reporting date and are recognised to the extent that it has become probable that future taxable profit will allow the deferred income tax to be recovered.

Deferred income tax assets and liabilities are measured at the tax rates that are expected to apply to the year when the asset is realised or the liability is settled, based on tax rates (and tax laws) that have been enacted or substantively enacted at the reporting date. Income taxes relating to items recognised directly in equity are recognised in equity and not in profit or loss.

Deferred tax assets and deferred tax liabilities are offset only if a legally enforceable right exists to set off current tax assets against current tax liabilities and the deferred tax assets and liabilities relate to the same taxable entity and the same taxation authority.

NOTE 1: SUMMARY OF SIGNIFICANT ACCOUNTING POLICIES (CONTINUED)**GOODS AND SERVICES AND SALES TAX**

Revenues, expenses and assets are recognised net of the amount of Goods and Services Tax (GST) except:

- (a) where the amount of GST incurred is not recoverable from the taxation authority, it is recognised as part of the cost of the asset or as part of an item of expense; or
- (b) for receivables and payables which are recognised inclusive of GST.

The net amount of GST recoverable from, or payable to, the taxation authority is included as part of receivables or payables.

CASH AND CASH EQUIVALENTS

Cash and cash equivalents include cash on hand and in the bank, and other short-term deposits. Bank overdrafts are shown separately in current liabilities on the Statement of Financial Position. For the purposes of the Statement of Cash Flows, cash and cash equivalents as defined above, net of outstanding bank overdrafts.

TRADE AND OTHER RECEIVABLES

Receivables are non-derivative financial assets with fixed or determinable payments that are not quoted in an active market. After initial measurement, such financial assets are subsequently measured at amortised cost using the effective interest rate method, less any impairment losses. This category generally applies to trade and other receivables. Trade and other receivables are generally due for settlement within no more than 30 days from the date of recognition.

Due to their current nature, the carrying amount of trade and other receivables approximates fair value. The carrying amount of trade and other receivables is reduced through the use of an allowance account and the loss is recognised in the profit or loss.

INVENTORIES

Inventories are valued at the lower of cost and net realisable value. Cost includes expenditure incurred in acquiring and bringing the inventories to their existing condition and location and is determined using the weighted average cost method.

PLANT AND EQUIPMENT

Plant and equipment is stated at historical cost less accumulated depreciation and any impairment in value. Capital work-in-progress is stated at cost and comprises all costs directly attributable to bringing the assets under construction ready to their intended use. Capital work-in-progress is transferred to property, plant and equipment at cost on completion. Depreciation is calculated on a straight-line basis over the estimated useful life of the asset, or where appropriate, over the estimated life of the mine.

Major depreciation periods are:

- Mine specific plant and equipment is depreciated using – the shorter of life of mine and useful life. Useful life ranges from 2 to 10 years.
- Buildings – the shorter of life of mine and useful life. Useful life ranges from 5 to 40 years.
- Office Plant and equipment is depreciated at 33% per annum for computers and office machines and 20% per annum for other office equipment and furniture.

Impairment

The carrying values of plant and equipment are reviewed for impairment when events or changes in circumstances indicate the carrying value may not be recoverable. For an asset that does not generate largely independent cash inflows, the recoverable amount is determined for the cash-generating unit to which the asset belongs.

If any such indication exists and where the carrying values exceed the estimated recoverable amount, the assets or cash-generating units are written down to their recoverable amount.

EXPLORATION EXPENDITURE

Recognition and measurement

Expenditure on the acquisition and development of mine properties within an area of interest are carried forward at cost separately for each area of interest. Accumulated expenditure is amortised over the life of the area of interest to which such costs relate on a production output basis. A regular review is undertaken of each area of interest to determine the appropriateness of continuing to carry forward costs in relation to that area of interest.

Impairment

The Company assesses each asset or cash generating unit (CGU) at the end of each reporting period to determine whether an indication of impairment exists. Where an indicator of impairment exists, a formal estimate of the recoverable amount is made, which is considered to be the higher of value in use (VIU) (being net present value of expected future cash flows of the relevant cash generating unit) and fair value less costs to sell" (FVLCS).

The future recoverability of capitalised mine development expenditure is dependent on a number of factors, including the level of proved, probable and inferred mineral resources, future technological changes, which could impact the cost, future legal changes (including changes to environmental restoration obligations) and changes to commodity prices.

The Company regularly reviews the carrying values of its mine development assets in the context of independent expert valuations, internal and external consensus forecasts for commodity prices and foreign exchange rates, with the application of appropriate discount rates for the assets concerned.

To the extent that capitalised mine development expenditure is determined not to be recoverable in the future, this will reduce profit in the period in which this determination is made. Capitalised mine development expenditure is assessed for recoverability in a manner consistent with property, plant and equipment.

Exploration and evaluation

Exploration and evaluation expenditure in relation to each separate area of interest are recognised as an exploration and evaluation asset in the year in which they are incurred where the following conditions are satisfied:

- (a) the rights to tenure of the area of interest are current; and
- (b) at least one of the following conditions is also met:
 - (i) the exploration and evaluation expenditure are expected to be recouped through successful development and exploration of the area of interest, or alternatively, by its sale; or
 - (ii) exploration and evaluation activities in the area of interest have not, at the reporting date, reached a stage which permits a reasonable assessment of the existence or otherwise of economically recoverable reserves, and active and significant operations in, or in relation to, the area of interest are continuing.

Exploration and evaluation assets are initially measured at cost and include acquisition of rights to explore, studies, exploratory drilling, trenching and sampling and associated activities and an allocation of depreciation and amortisation of assets used in exploration and evaluation activities. General and administrative costs are only included in the measurement of exploration and evaluation costs where they are related directly to operational activities in a particular area of interest.

Indirect costs that are included in the cost of an exploration and evaluation asset include, among other things, charges for depreciation of equipment used in exploration and evaluation activities. If an area of interest is abandoned or is considered to be of no further commercial interest, the accumulated exploration costs relating to the area are written off against income in the year of abandonment.

Exploration and evaluation assets are assessed for impairment when facts and circumstances suggest that the carrying amount of an exploration and evaluation asset may exceed its recoverable amount. The recoverable amount of the exploration and evaluation asset (or the cash-generating unit(s) to which it has been allocated, being no larger than the relevant area of interest) is estimated to determine the extent of the impairment loss (if any). Where a decision has been made to proceed with development in respect of a particular area of interest, the relevant exploration and evaluation asset is tested for impairment and the balance is then reclassified to development.

NOTE 1: SUMMARY OF SIGNIFICANT ACCOUNTING POLICIES (CONTINUED)**TRADE AND OTHER PAYABLES**

Trade and other payables amounts represent liabilities for goods and services provided to the entity prior to the end of the year and which are unpaid. The amounts are unsecured and are usually paid within 30 days of invoice.

PROVISIONS

Provisions are recognised when the Company has a present obligation (legal or constructive) as a result of a past event, it is probable that an outflow of resources embodying economic benefits will be required to settle the obligation and a reliable estimate can be made of the amount of the obligation. Provisions are measured at the present value of management's best estimate of the expenditure required to settle the present obligation at the reporting date. The discount rate used to determine the present value reflects current market assessments of the time value of money and the risks specific to the liability. The increase in the provision resulting from the passage of time is recognised in finance costs.

ORDINARY SHARES

Ordinary shares have no par value and have the right to receive dividends as declared and, in the event of the winding up of the Company, to participate in proceeds from the sale of all surplus assets in proportion to the number of and amounts paid up on the shares held. Ordinary shares entitle their holder to one vote, either in person or by proxy, at a meeting of the Company. Share capital represents the nominal value of shares that have been issued. Any transaction costs associated with the issuing of shares are deducted from share capital, net of any related income tax benefits.

NOTE 2: ACTUAL AND PROPOSED TRANSACTIONS TO ARRIVE AT THE PRO-FORMA FINANCIAL INFORMATION

The pro-forma historical financial information has been prepared by adjusting the statement of financial position of the Company as at 30 June 2021 to reflect the financial effects of the following subsequent events which have occurred since 30 June 2021:

- (a) the issue of 1,650,000 Shares at \$0.05 per Share and 3,000,000 Shares at \$0.10 per Share as seed funding raising \$382,500;
- (b) the issue 25,000,000 Metals X Options (exercisable at \$0.25 with a term of 3 years from issue) to Metals X;
- (c) the issue of 9,000,000 Director Options (exercisable at \$0.20 with a term of 3 years from issue) to the Directors; and
- (d) use of funds subsequent to 30 June 2021 of \$93,343,

and the following pro forma transactions which are yet to occur, but are proposed to occur at or following completion of the Offer:

- (e) the issue of 25,000,000 Shares totalling \$5,000,000 to Metals X for the Acquisition;
- (f) the issue of 50,000,000 Shares at \$0.20 per Share to raise \$10,000,000 before costs (Minimum Subscription) or the issue of 60,000,000 Shares at \$0.20 per Share to raise \$12,000,000 before costs (Maximum Subscription);
- (g) capital raising costs with respect to payments to the Lead Manager are estimated to be \$396,000 based on the Minimum Subscription and \$528,000 based on the Maximum Subscription;
- (h) further costs in relation to the Offer of \$532,058 and \$534,473 respectively (Minimum and Maximum Subscriptions); and
- (i) the issue of 800,000 Lead Manager Options (with an exercise price of \$0.30 and a term of 3 years) to Blue Ocean Equities (a Lead Manager) as consideration for capital raising services provided in connection with the Offer (Minimum and Maximum Subscriptions).

NOTE 3: RELATED PARTY TRANSACTIONS

Refer to Section 6 for the Board and management interests.

NOTE 4: COMMITMENTS AND CONTINGENT LIABILITIES

At the date of the report, no other material commitments or contingent liabilities exist, that the Company is aware of, other than disclosed in this Prospectus.

NOTE 5: SUBSEQUENT EVENTS

Subsequent to 30 June 2021, there are no matters or circumstances that have occurred, that the Company is aware of, other than disclosed in the pro forma adjustments.

For personal use only

06.

Board, Management & Corporate Governance

6.1 BOARD OF DIRECTORS

As at the Prospectus Date, the Board comprises:

WARREN HALLAM

Non-Executive Chairman

B.App Sci (Metallurgy), MSc (Min. Econ), Grad Dip Bus

Warren Hallam has been involved in the mining industry for over 35 years' in various technical, managerial and financial roles across a broad range of commodities, predominately gold, copper, nickel, tin and Iron ore.

During the period 2005 to 2018 Warren was a member of the senior leadership team at Metals X (both as executive director and managing director) and played a critical role in the development of Metals X into a leading global tin and top-10 gold producer. Warren has held a range of senior operational, strategic and business development roles with diversified ASX-100 resource companies and has held several managing director roles, notably with Metals Exploration Ltd, Metals X, Capricorn Metals Ltd and Millennium Minerals Ltd, and been a non-executive director of Westgold Resources Ltd. He is currently non-executive chairman of ASX listed Nelson Resources Ltd and Kingfisher Mining Ltd, and is a non-executive director of Essential Metals Ltd.

RODERICK CORPS

Managing Director

Rod Corps has been involved in the finance industry for 30 years, having worked as a stockbroker for Porter Western Ltd (now Macquarie Group), and Morgan Stanley and JP Morgan in the United Kingdom.

Rod has been a director of Eternal Resources Ltd (taken over by Aziana Ltd - now Brainchip Holdings Ltd ASX:BRN) and Voyager Global Ltd - now Cycliq Group Ltd (ASX:CYQ). From 2013 to 2021 Rod was the corporate & investor relations manager for ASX listed Westgold Resources Ltd (ASX:WGXO). He is currently a non-executive director of Marketech Limited.

BRETT SMITH

Non-Executive Director

B.Chem Eng, MBA, M Res Methodology,

Brett Smith has participated in the development of a number of mining and mineral processing projects including coal, iron ore, base and precious metals. He has also managed engineering and construction companies in Australia and internationally.

Brett has served on the boards of private mining and exploration companies and has over 32 years' international experience in the engineering, construction and mineral processing businesses. Brett is an executive director of Metals X Limited, executive director and deputy chairman of Hong Kong listed company APAC Resources Limited, executive director of Hong Kong listed company Dragon Mining Limited and a non-executive director of ASX listed companies Prodigy Gold NL and Tanami Gold NL.

As at the Prospectus Date, the Chairman, Warren Hallam, is not considered independent because he is a substantial Shareholder in the Company. Following completion of the Public Offer, Warren Hallam will cease to be a substantial Shareholder and may then be regarded as an independent Director.

Brett Smith, a Non-Executive Director is not considered independent because he is the managing director of Metals X, a substantial Shareholder of the Company.

6.2 COMPANY SECRETARY AND CHIEF FINANCIAL OFFICER

AMANDA BURGESS

Company Secretary and Chief Financial Officer

B.Econs, CPA

Ms Burgess is an accounting and company secretary professional with over 30 years' experience. She graduated from University of WA with a Bachelor of Economics degree and is a member of CPA Australia (CPA). Ms Burgess currently holds CFO and company secretary positions with various Australian companies, including ASX listed company Recharge Metals Limited.

6.3 INTERESTS OF DIRECTORS

Except as disclosed in this Prospectus, no Director of the Company (or entity in which they are a partner or director) has, or has had in the two years before the Prospectus Date, any interests in:

- (a) the formation or promotion of the Company; or
- (b) property acquired or proposed to be acquired by the Company in connection with its formation or promotion of the Public Offer; or
- (c) the Offers, and

no amounts have been paid or agreed to be paid and no value or other benefit has been given or agreed to be given to:

- (d) any Director to induce him or her to become, or to qualify as, a Director; or
- (e) any Director of the Company for services which he or she (or an entity in which they are a partner or director) has provided in connection with the formation or promotion of the Company or the Public Offer.

6.4 SECURITY HOLDINGS OF DIRECTORS

The Directors and their related entities have the following interests in Securities as at the Prospectus Date:

Director	Shares	% ¹	Options ²	% ¹
Rod Corps	1,500,001	25%	3,000,000	8.82%
Warren Hallam	1,750,001	29.17%	3,000,000	8.82%
Brett Smith	Nil	0%	3,000,000	8.82%

Notes:

1. Percentages of total Shares and total Options based on 6,000,002 Shares and 34,000,000 Options being on issue at the Prospectus Date.
2. Refer to Section 8.3 for the terms and conditions of the Director Options.
3. Warren Hallam holds his interest in the Securities indirectly through Warren & Leonie Hallam <Hallam Superannuation Fund> (1,750,000 Shares and 3,000,000 Director Options).

Based on the intentions of the Directors at the Prospectus Date in relation to the Offers, the Directors and their related entities will have the following interests in Securities on Admission at Minimum Subscription to the Public Offer:

Director	Shares	% ¹	Options ²	% ¹
Rod Corps ³	1,500,001	1.875%	3,000,000	8.62%
Warren Hallam ⁴	2,026,4223	2.5%	3,000,000	8.62%
Brett Smith ⁵	5,7874	0%	3,000,000	8.62%

Notes:

1. Assuming that there are a total of 81,000,002 Shares and 34,800,000 Options on issue at Admission (based on the Minimum Subscription under the Public Offer) and that no further Securities are issued or Options are exercised.
2. Refer to Section 8.3 for the terms and conditions of the Director Options.
3. As at the Prospectus Date, Rod Corps does not intend to apply for Shares under the Public Offer.
4. Warren Hallam holds his interest in Securities indirectly through Warren & Leonie Hallam <Hallam Superannuation Fund>. As at the Prospectus Date, Warren Hallam intends to apply for 250,000 Shares under the Public Offer. It is anticipated that Warren & Leonie Hallam <Hallam Superannuation Fund> will be entitled to up to approximately 26,421 Shares under the Distribution by reason of being a Metals X Shareholder (based on its holding of 958,848 Metals X Shares).
5. As at the Prospectus Date, Brett Smith does not intend to apply for Shares under the Public Offer. It is anticipated that Brett Smith will be entitled to up to approximately 5,787 Shares under the Distribution by reason of being a Metals X Shareholder (based on his holding of 210,000 Metals X Shares).

6.5 REMUNERATION OF DIRECTORS

The Constitution provides that the Company may remunerate the Directors. The remuneration shall, subject to any resolution of a general meeting, be fixed by the Directors. The maximum aggregate amount of fees that can be paid to Non-Executive Directors is currently set at \$300,000 per annum.

As at the Prospectus Date:

- (a) the salary payable to the CEO Rod Corps is \$250,000 per annum (plus statutory superannuation entitlements) pursuant to executive services agreement set out in Section 7.5; and
- (b) the fees payable to the Non-Executive Directors are \$60,000 per annum (plus statutory superannuation) to Warren Hallam (Chairman) and \$40,000 per annum (plus statutory superannuation) to Brett Smith (Non-Executive Director), pursuant to the letters of appointment set out in Section 7.6.

6.6 RELATED PARTY TRANSACTIONS

The Company has entered into the following related party transactions on arms' length terms:

- (a) the executive services agreement or letters of appointment with each of the Directors on standard terms (refer to Sections 7.5 and 7.6 for details); and
- (b) deeds of indemnity, insurance and access with each of the Directors on standard terms (refer to Section 7.7 for details).

At the Prospectus Date, no other material transactions with related parties and Directors' interests exist that the Directors are aware of, other than those disclosed in the Prospectus.

6.7 COMPOSITION OF THE BOARD

The election and continued appointment of Board members is substantially the province of the Shareholders in general meeting.

The Board currently consists of one Executive Director, and two Non-Executive Directors (none of whom the Board considers independent).

The Chairman, Warren Hallam, is not considered independent because he is a substantial Shareholder in the Company.

Brett Smith, a non-executive Director is not considered independent because he is the managing director of Metals X, a substantial Shareholder of the Company.

The CEO, Rod Corps, is not independent because he is a full-time employee of the Company.

As the Company's activities develop in size, nature and scope, the composition of the Board will be reviewed, including the possible appointment of independent Directors.

6.8 ROLE OF THE BOARD

The Board is responsible for the governance of the Company.

The Board's role and responsibilities include the following:

- (a) setting the strategic objectives or direction of the Company;
- (b) evaluating, providing input into, and approving, budgets and business plans developed by management;
- (c) directing, monitoring and assessing the Company's performance against ongoing strategies, budgets and business plans;
- (d) evaluating, providing input into, approving and monitoring capital management, major capital expenditure and all acquisitions, divestments or other corporate transactions, including the issue of securities;
- (e) appointing, and where appropriate, removing the Company's chief executive officer (CEO) or equivalent;
- (f) approving the appointment, and where appropriate, the removal of any other officer or executive the Board has discretion to appoint in accordance with the Constitution;
- (g) delegating day to day administration and the implementation of strategies approved by the Board to the CEO;
- (h) approving criteria to assess the performance of senior executives and monitoring and, where necessary, evaluating senior executives against that criteria;
- (i) developing and implementing a process for periodically evaluating the performance of the Board, any committees and individual Directors;
- (j) ensuring the Company complies with the Constitution and all legal and regulatory obligations, including under the Corporations Act and the ASX Listing Rules;
- (k) ensuring ethical conduct within the Company and compliance with the Company's corporate governance policies;
- (l) overseeing the integrity of the Company's accounting and corporate reporting systems;
- (m) overseeing the Company's continuous disclosure process and compliance with the Company's Continuous Disclosure Policy;

6.8 ROLE OF THE BOARD (CONTINUED)

- (n) monitoring and reviewing the ongoing performance and compliance of the Company's corporate governance practices, policies and procedures adopting and applying appropriate ethical standards in relation to the management of the Company and the conduct of the business;
- (o) ensuring that the Company establishes and maintains a risk management framework or policy appropriate to the Company's profile and operations;
- (p) identifying principal risks to the Company's business and establishing acceptable levels of risk within which the Board expects and permits the executive management of the Company to operate; and
- (q) reviewing and approving the Company's internal compliance and control, risk management and legal compliance systems to determine the integrity and effectiveness of those systems and to continually improve those systems.

6.9 REMUNERATION ARRANGEMENTS

The remuneration of any Executive Director will be decided by the Board and must not be calculated as a commission on, or percentage of, operating revenue.

In addition, subject to any necessary Shareholder approval, a Director may be paid fees or other amounts as the Directors determine where a Director performs special duties or otherwise performs services outside the scope of the ordinary duties of a Director (e.g. non-cash performance incentives such as Options).

Directors are also entitled to be paid reasonable travel and other expenses incurred by them in the course of the performance of their duties as Directors.

The Board reviews and approves the Company's remuneration policy in order to ensure that the Company is able to attract and retain executives and Directors who will create value for Shareholders, having regard to the amount considered to be commensurate for an entity of the Company's size and level of activity as well as the relevant Directors' time, commitment and responsibility.

The Board is also responsible for reviewing any employee incentive and equity-based plans including the appropriateness of performance hurdles and total payments proposed.

6.10 AUDIT AND RISK

The Company will not have a separate audit or risk committee until such time as the Board is of a sufficient size and structure, and the Company's operations are of a sufficient magnitude for a separate committee to be of benefit to the Company.

In the meantime, the full Board will carry out the duties that would ordinarily be assigned to that committee under the written terms of reference for that committee, including but not limited to, monitoring and reviewing any matters of significance affecting financial reporting and compliance, the integrity of the financial reporting of the Company, the Company's internal financial control system and risk management systems and the external audit function.

The Company in general meetings is responsible for the appointment of the external auditors of the Company, and the Board from time to time will review the scope, performance and fees of those external auditors.

6.11 CORPORATE GOVERNANCE POLICIES AND PROCEDURES

The Company has adopted comprehensive systems of control and accountability as the basis for the administration of corporate governance. The Board is committed to administering the Company's policies and procedures with openness and integrity, pursuing the true spirit of corporate governance commensurate with the Company's needs.

To the extent applicable, the Company has adopted the 4th edition of the ASX Corporate Governance Council's Corporate Governance Principles and Recommendations (**ASX Recommendations**).

In light of the Company's size and nature, the Board considers that the current Board is a cost effective and practical method of directing and managing the Company. As the Company's activities develop in size, nature and scope, the size of the Board and the implementation of additional corporate governance policies and structures will be reviewed.

The Company's main corporate governance policies and practices as at the Prospectus Date are detailed below. The Company's corporate governance policies and charters are available at the corporate governance section of the Company's website at <https://nicoresources.com.au/corporate-governance/>.

Charter/Policy	Purpose
Board Charter	To govern the operations of the Board. It sets out the Board's role and responsibilities, composition, structure and membership requirements. The charter states the role of the Board, which is described in Section 6.8.
Code of Conduct	To state the standards of lawful, responsible and ethical conduct expected of the Company's Directors, officers and employees, including with respect to personal integrity, compliance with laws, avoiding conflicts of interest, use of the Company's property or information and not engaging in discrimination, corruption or bribery.
Audit and Risk Committee Charter	An audit and risk committee has not been established as a separate committee of the Board; however the full Board will act in accordance with the charter. The charter sets out the role, authority, responsibilities, composition and procedural requirements of the committee (or the full Board pending establishment of the committee) with respect to: <ul style="list-style-type: none"> • the integrity and quality of interim and annual financial reporting and disclosures of the Company; • the integrity of the external audit of the Company (as applicable); • identification of key business, financial and regulatory risks relevant to the Company; • updating and implementing the risk management framework for the Company; • compliance by the Company with relevant laws, regulations, standards and codes; and • the adequacy of the internal financial and risk management controls of the Company.
Remuneration and Nomination Committee Charter	A remuneration and nomination committee has not been established as a separate committee of the Board, however the full Board will act in accordance with the charter. The charter sets out the role, authority, responsibilities, composition and procedural requirements of the committee (or the full Board pending establishment of the committee) with respect to: <ul style="list-style-type: none"> • the development, review and evaluation of the Company's remuneration policies; • remuneration of executive Directors and executives; • the remuneration of Non-Executive Directors; • equity based remuneration and incentives; • nomination and appointment of proposed Directors and executives and criteria for nomination; • evaluation of performance of the Board, Directors and executives; and • succession planning.
Continuous Disclosure Policy	To: <ul style="list-style-type: none"> • establish procedures to ensure that the Company complies with its continuous disclosure obligations under the ASX Listing Rules; • ensure disclosure of material information is clear, fair, prompt, balanced and objective; and • promote open, proactive disclosure.
Shareholder Communication Policy	To encourage and facilitate: <ul style="list-style-type: none"> • timely, effective, open and honest communication with Shareholders through accessible and fair means; and • optimum attendance at and participation in shareholder meetings.

Charter/Policy	Purpose
Securities Trading Policy	<p>To:</p> <ul style="list-style-type: none"> assist employees and restricted persons to comply with their legal obligations in relation to trading in the Company's securities; raise awareness and minimize any potential for breach of the prohibitions on insider trading contained in Part 7.10 of the Corporations Act; establish the Company's policy and procedure for employees' and restricted Persons' trading in Securities; meet the Company's obligations under the ASX Listing Rules to maintain a securities trading policy; and maintain a proper market for the Company's Securities and ensure the Company's reputation and integrity are not adversely impacted by perceptions of trading in the Company's securities.
Anti-bribery and Corruption Policy	<p>To:</p> <ul style="list-style-type: none"> outline the Company's position on bribery and other corrupt behaviour; outline the responsibilities of the Company's Directors, officers, executives, employees, consultants, contractors and advisors in observing and upholding the Company's position against bribery and corruption; <p>Under the policy, the Company will:</p> <ul style="list-style-type: none"> not engage in corrupt business practices; implement measures to prevent bribery and corruption by all personnel; and at a minimum, endeavour to comply with all applicable laws, regulations and standards, including anti-bribery and corruption laws. The policy outlines what constitutes bribery and corruption. The policy also outlines the process to follow if there are concerns that any personnel are not complying with the policy.
Diversity Policy	<p>The objectives of the Company and the policy are to:</p> <ul style="list-style-type: none"> recognize that diversity and inclusivity contribute to corporate success; promote a Company culture that upholds diversity, inclusivity and equality; ensure the Company fosters a safe, fair and respectful working environment for all personnel; and ensure the Company provides and maintains equal employment opportunities for all personnel and candidates for Board appointment or employment with the Company.
Risk Management Policy	<p>To recognise and establish responsibility for:</p> <ul style="list-style-type: none"> designing and implementing a risk management framework; ensuring the Company has appropriate processes in place to manage risk; identifying, assessing, monitoring and managing risk; and ensuring appropriate responsibilities are delegated.
Whistleblower Policy	<p>To:</p> <ul style="list-style-type: none"> deter wrongdoing and encourage officers and employees of the Company to report any wrongdoing through the provision of safe and secure processes which protect and support individuals who disclose wrongdoing; outline the mechanisms as to how a concern about suspected or observed improper conduct or wrongdoing can be raised; and outline the measures in place to protect an officer Director or employee who alerts the Company and/or a regulatory authority to such matters within the Company.

6.12 CORPORATE GOVERNANCE COMPLIANCE WITH THE ASX RECOMMENDATIONS

To the extent practicable, the Company has adopted the ASX Recommendations.

The Company's compliance with the ASX Recommendations as at the Prospectus Date is set out in the Company's Corporate Governance Statement, a copy of which is available at the corporate governance section of the Company's website at <https://nicoresources.com.au/corporate-governance/>

Following Admission, the Company will be required to report any departures from the ASX Recommendations in its annual financial report.

The Company's departures from the ASX Recommendations as at the Prospectus Date are detailed in the table below.

Principles and Recommendations	Explanation for Departures
2.1 The board of a listed entity should have a nomination committee.	<p>The Company does not comply with Principle 2.1. The Company is not of a relevant size to consider formation of a nomination committee to deal with the selection and appointment of new Directors and as such a nomination committee has not been formed.</p> <p>Nominations of new Directors are considered by the full Board. If any vacancies arise on the Board, all directors are involved in the search and recruitment of a replacement. The Board has taken a view that the full Board will hold special meetings or sessions as required. The Board is confident that this process for selection, including undertaking appropriate checks before appointing a person, or putting forward to Security holders a candidate for election, and review is stringent and full details of all Directors will be provided to Shareholders in the annual report and on the Company's website.</p>
2.4 A majority of the board of a listed entity should be independent directors.	<p>Due to the size and scale of the Company's current activities, the Board does not consist of a majority of independent directors. However, although the Board does not follow Recommendation 2.4, to facilitate independent decision-making, the Board has agreed procedures for directors to have access in appropriate circumstances to independent professional advice.</p> <p>As the Company grows, the Board will consider the appointment of additional independent Directors</p>
4.1 The board of a listed entity should have an audit committee of at least three members that are non-executive.	<p>The Board has not established a separate audit committee. The full Board carries out the duties that would ordinarily be assigned to the audit committee.</p> <p>The Board considers that the Company is not currently of a size, nor are its affairs of such complexity to justify having a separate audit committee.</p>
7.1 The board of a listed entity should have a risk committee.	<p>The Board has not established a separate Risk Management Committee. The Board is ultimately responsible for risk oversight and risk management. Discussions on the recognition and management of risks are considered by the Board.</p> <p>The Board considers that the Company is not currently of a size, nor are its affairs of such complexity to justify having a separate risk committee.</p>
8.1 The board of a listed entity should have a remuneration committee of at least three members, a majority of whom are independent.	<p>The Board as a whole performs the function of the Remuneration committee which includes setting the Company's remuneration structure, determining eligibilities to incentive schemes, assessing performance and remuneration of senior management and determining the remuneration and incentives of the Board.</p> <p>The Board may obtain external advice from independent consultants in determining the Company's remuneration practices, including remuneration levels, where considered appropriate.</p> <p>The Board considers that the Company is not currently of a size, nor are its affairs of such complexity to justify having a separate remuneration committee.</p>

07. Material Contracts

7.1 INTRODUCTION

The Directors consider that certain contracts entered into by the Company are material to the Company or are of such a nature that an investor may wish to have particulars of them when assessing whether to apply for Shares under the Offers. The provisions of such material contracts are summarised in this Section.

7.2 SHARE SALE AGREEMENT FOR ACQUISITION OF METALS EXPLORATION

Pursuant to a Share Sale and Subscription Agreement dated 3 November 2021 (**Share Sale Agreement**) between the Company and Metals X, the Company has agreed to acquire from Metals X 100% of the issued capital of Metals Exploration (**Acquisition**) and upon completion of the Acquisition, the Company will acquire the Central Musgrave Project, comprising:

- (a) exploration licences E69/535 and E69/3065 and miscellaneous licences L69/12, L69/19 and L69/27 located in Western Australia (**WA Tenements**); and
- (b) exploration licences EL5860 and EL6240 located in South Australia (**SA Tenements**).

On completion of the Acquisition, the Company will acquire 100% control of Metals Exploration and the following wholly owned subsidiaries of Metals Exploration:

- (a) Hinckley Range which is the holder of the WA Tenements;
- (b) Austral Nickel which is the holder of the SA Tenements; and
- (c) Metex Nickel.

The total consideration payable by the Company for the Acquisition will be satisfied by the Company issuing 25,000,000 Shares to Metals X (**Consideration**).

The Consideration has been determined on the basis that the offer price of Shares under this Prospectus is \$0.20 per Share resulting in the aggregate value of the Consideration being \$5,000,000.

Completion under the Share Sale Agreement is conditional on satisfaction of various conditions precedent, including the following:

- (a) FIRB notifying MLX under the *Foreign Acquisitions and Takeovers Act 1975* (Cth) (**FATA**) that the Treasurer of Australia (or his delegate) has no objections to the transactions contemplated by the Share Sale Agreement (including the Distribution) proceeding, either following a formal notification (being a notification pursuant to the notification provisions of the FATA on the basis that FATA applies) or on an informal basis (being by way of a voluntary notification);

- (b) the following not being withdrawn or ceasing to apply:
- (i) ASX notification to the effect that ASX listing rule 11.4 does not apply to the transactions contemplated by the Share Sale Agreement; and
 - (ii) ASX determination on an “in principle” basis that the Shares to be issued to Metals X as Consideration will not be classified as “restricted securities” under the ASX Listing Rules if the Company is admitted to the official list of ASX;
- (c) Metals X providing the Company with an Application Form and payment in respect of 20,000,000 Shares to be subscribed for by Metals X under the Public Offer;
- (d) Metals X's shareholders approving a reduction in Metals X's capital by way of an in-specie distribution of the Shares to be issued to Metals X as Consideration in accordance with sections 256B and 256C of the Corporations Act and the constitution of Metals X;
- (e) the Company conducting the Public Offer and receiving valid Applications for Shares to raise the Minimum Subscription of \$10,000,000 before costs of the Public Offer (including the Shares to be subscribed for by Metals X as described below);
- (f) the Company receiving conditional approval from ASX for Admission on terms acceptable to the Company (acting reasonably);
- (g) Metals X obtaining any consents or waivers from third parties or assumption of obligations which may be required as a result of the transactions contemplated in the Share Sale Agreement;
- (h) no event or circumstance occurring that has or will have a material adverse effect on the business, condition (financial or otherwise), assets, liabilities or prospects of:
- (i) Metals Exploration, Hinckley Rage, Austral Nickel or Metex Nickel (taken as a whole) or the Central Musgrave Project; or
 - (ii) Company (other than as a result of this Prospectus or the transactions contemplated in the Share Sale Agreement); and
- (i) each party obtaining all required approvals or authorisations necessary to give effect to the Share Sale Agreement.

Completion of the Share Sale Agreement will occur on a date that is 5 business days after the conditions described above are satisfied or waived in accordance with its terms.

Under the Share Sale Agreement, Metals X has agreed to subscribe for 20,000,000 Shares under the Public Offer at \$0.20 per Share to raise \$4,000,000 and the Company has agreed to issue these Shares to Metals X on and subject standard terms and conditions regarding subscription of the Shares set out in the Share Sale Agreement.

The Company has granted 25,000,000 Options to Metals X as a signing bonus for Metals X entering into the Share Sale Agreement. These Options do not constitute any part of the payment of the Consideration. The Options granted to Metals X are exercisable at \$0.25 each and will expire 3 years after grant. They have been granted on the terms and conditions summarised in Section 8.2.

The Share Sale Agreement otherwise contains provisions considered standard for an agreement of its nature (including representations, warranties and confidentiality provisions).

Relationships concerning the Share Sale Agreement

The following relationships concerning the Share Sale Agreement are disclosed:

- (a) Metals X is a promoter of the Company;
- (b) Metals X will be the major Shareholder of the Company, it will hold 21,100,000 Shares, representing a maximum of 25.92% of the total Shares of the Company upon completion of the Offers (at Minimum Subscription to the Public Offer);
- (c) the 25,000,000 Shares to be issued as the Consideration under the Share Purchase Agreement are to be distributed by Metals X to Eligible Metals X Shareholders, who will collectively hold up to 25,000,000 Shares, representing a maximum of 30.86% of the total Shares of the Company upon completion of the Distribution and the Offers (at Minimum Subscription to the Public Offer);

7.2 SHARE SALE AGREEMENT FOR ACQUISITION OF METALS EXPLORATION (CONTINUED)

- (d) Brett Smith, a Non-Executive Director of the Company, is the managing director of Metals X; Brett Smith directly and indirectly holds 210,000 shares in Metals X (representing less than 0.03% of the total number of Metals X Shares as at the Prospectus Date). Based on his present shareholding interest in Metals X, Brett Smith will be entitled to receive approximately 5,787 Shares under the Distribution; and
- (e) pursuant to a Royalty Deed between Metals X, Austral Nickel and Hinckley Range dated 17 May 2021 in respect of both the WA Tenements and the SA Tenements, Metals X is entitled to a 1.75% net smelter return royalty in respect of any mineral or metallic product extracted or recovered from the area of the WA Tenements and the SA Tenements.

7.3 AGREEMENTS AFFECTING THE TENEMENTS

Upon completion of the Share Sale Agreement, the Company's subsidiaries will remain party to, and will be required to observe the terms and conditions of, various agreements concerning the Tenements, comprising:

- (a) a number of agreements with the holders of native title in respect of the WA Tenements to, among other things, set out the parameters for the conduct of exploration and mining activities within the stipulated area, provide for the search for groundwater and ensure that any exploration and mining activities avoid damage, disturbance or interference to or with Aboriginal sites;
- (b) a number of agreements with representatives of the traditional owners of the SA Tenements to, among other things, set out the parameters for the conduct of exploration and mining activities within the stipulated area and ensure that any exploration and mining activities avoid damage, disturbance or interference to or with Aboriginal sites;
- (c) a parent company guarantee between Metals X and the holders of native title in respect of the WA Tenements under which Metals X guarantees the obligations of Hinckley Range to the native title holders (**Parent Company Guarantee**);
- (d) a deed of indemnity between the Company and Metals X under which the Company agrees to indemnify Metals X for any claim made against Metals X under the Parent Company Guarantee;
- (e) a royalty deed between Metals X, Austral Nickel and Hinckley Range, pursuant to which Metals X is entitled to a 1.75% net smelter return royalty in respect of any mineral or metallic product extracted or recovered from the area of the Tenements; and
- (f) a royalty deed whereby Barrick (PD) Australia Pty Ltd is entitled to a royalty equal to 1.5% of gross sale revenue received by Austral Nickel in respect of any marketable mineral or other commodities recovered or produced from EL 6240.

Information concerning these agreements is set out in Schedule 5 to the Solicitors' Report in Schedule 2 of this Prospectus.

7.4 LEAD MANAGER MANDATE

The Company has entered into a mandate with Blue Ocean Equities and Marketech Online Trading dated 1 October 2021 to provide corporate advisory services and to act as lead manager in respect of the Public Offer (**Lead Manager Mandate**).

The Company will pay the following fees to the Lead Managers (or their nominees) pursuant to the Lead Manager Mandate, subject to the successful completion of the Public Offer:

- (a) a management fee of 2% on the total amount raised in the Public Offer (excluding \$4 million raised from Metals X); and
- (b) a capital raising fee of 4% on the total amount raised in the Public Offer (excluding \$4 million raised from Metals X).

50% of these fees will be payable to Blue Ocean Equities and 50% of these fees will be payable to Marketech Online Trading.

Pursuant to the Lead Manager Mandate, the Company has also agreed to issue the Lead Manager (or its nominees) 800,000 Lead Manager Options exercisable at \$0.30 each within 3 years of the date of grant of the Options on the terms and conditions set out in Section 8.2.

Please see Section 2.6 for further information regarding the Lead Managers' interests in the Public Offer.

The Lead Manager Mandate contains additional provisions considered standard for agreements of this nature.

7.5 EXECUTIVE SERVICES AGREEMENT – MANAGING DIRECTOR

The Company has entered into an executive services agreement with the Managing Director, Rod Corps effective 1 September 2021, pursuant to which Mr Corps is employed on a full-time basis as Executive Director and Chief Executive Officer responsible for the overall management and supervision of the activities, operations and affairs of the Company, subject to the overall control and direction of the Board.

Pursuant to the agreement Mr Corps is entitled to receive a salary of \$250,000 per annum (plus statutory superannuation entitlements) from 1 September 2021.

Mr Corps is entitled to participate in the Company's Employee Incentive Plan and the Company has granted Mr Corp 3,000,000 Director Options exercisable at \$0.20 each within 3 years from the date of grant of the Options on the terms and conditions set out in Section 8.3 pursuant to the Employee Incentive Plan.

The Board may, in its absolute discretion, invite Mr Corps to participate in bonus and/or other incentive schemes in the Company that it may implement from time to time, subject to Shareholder approval.

The agreement is for an indefinite term, continuing until terminated by either the Company or Mr Corps giving not less than three months' written notice of termination to the other party (or shorter period in limited circumstances).

The Company may terminate Mr Corps' employment immediately for certain matters including serious misconduct, breach of duties or bankruptcy, or if Mr Corps is incapacitated due illness, accident or other cause and is unable to perform his duties for 3 consecutive months or period aggregating more than 3 months in any 12-month period.

Mr Corps is also subject to restrictions in relation to the use of confidential information during and after his employment with the Company ceases and being directly or indirectly involved in a competing business during the continuance of his employment with the Company and for a period of three months after his employment with the Company ceases, on terms which are otherwise considered standard for agreements of this nature.

The agreement contains additional provisions considered standard for agreements of this nature.

7.6 NON-EXECUTIVE DIRECTOR LETTERS OF APPOINTMENT

The Company has entered into a letter of engagement with each Non-Executive Director (Warren Hallam and Brett Smith) confirming their appointment and terms of engagement as Non-Executive Directors.

The key terms of each letter of appointment are as follows:

- (a) Each Non-Executive Director is entitled to be paid an annual director's fee (plus statutory superannuation) for his services as a Non-Executive Director. Details of the current fees are set out in Section 6.5.
- (b) The Company agrees to grant each Non-Executive Director 3,000,000 Director Option under the Company's Employee Incentive Plan. The terms of the Director Options are set out in Section 8.3 and a summary of the Employee Incentive Plan is set out in Section 8.4.
- (c) Each Non-Executive Director is expected to discharge his duties in accordance with applicable statutory and general law duties of a director.
- (d) Each Non-Executive Director must make all necessary disclosures to the Company in relation to all interests, including interests in Securities, and matters which impact his independence and any matters which may give rise to a conflict of interest. The letter of appointment incorporates a standard agreement in a form specified by ASX requiring the Director to give notice to the Company of his interests in Securities and in contracts which may result in the acquisition of Securities, in a manner to enable the Company to lodge relevant notifications of such interests with ASX.
- (e) Each Non-Executive Director must keep information regarding the Company received in the course of his directorship confidential, except if disclosure is required by law, is in the course of performing his duties as a Director, the information becomes public without breach by the Non-Executive Director, or the Company provides its prior written consent.
- (f) All intellectual property rights created or developed in the course of the Director performing his duties or work for the Company vests in the Company.
- (g) A Director may seek independent professional advice in relation to any matter before the Board at the cost of the Company.

The letters of engagement otherwise contain terms and conditions considered customary for engagement letters of this nature.

7.7 DEEDS OF INDEMNITY, INSURANCE AND ACCESS

The Company has entered into deeds of indemnity, insurance and access with each Director and the Company Secretary (each an **officer**). The key terms of the deeds are as follows:

- (a) the Company has agreed to indemnify and keep indemnified the officer, to the maximum extent permitted by law, from certain liabilities incurred by the officer in acting as an officer of the Company (and as acting as an officer of certain other relevant entities);
- (b) the Company must, to the extent permitted by law, procure and pay the premium for an insurance policy which insures the officer against all liabilities incurred by the officer acting directly or indirectly as an officer of the Company (or certain other relevant entities), subject to certain limitations;
- (c) the Company must provide access to certain company records which are relevant to the officer's position with, or any claim reasonably anticipated to be made against the officer in relation to matters arising in the course of the officer acting in connection with the affairs of, the Company (or certain other relevant entities), for a period of seven years after the officer has ceased to be an officer of the Company.

The deeds of indemnity, insurance and access otherwise contains terms and conditions that are considered standard for agreements of their nature.

For personal use only

08. Additional Information

8.1 RIGHTS ATTACHING TO SHARES

A summary of the rights attaching to the Shares is detailed below. This summary is qualified by the full terms of the Constitution (a full copy of the Constitution is available from the Company on request free of charge) and does not purport to be exhaustive or to constitute a definitive statement of the rights and liabilities of Shareholders. These rights and liabilities can involve complex questions of law arising from an interaction of the Constitution with statutory and common law requirements. For a Shareholder to obtain a definitive assessment of the rights and liabilities which attach to the Shares in any specific circumstances, the Shareholder should seek legal advice.

- (a) **(Ranking of Shares):** At the Prospectus Date, all Shares are of the same class and rank equally in all respects. Specifically, the Shares issued pursuant to this Prospectus will rank equally with existing Shares.
- (b) (Voting rights): Subject to any rights or restrictions, at general meetings:
 - (i) every Shareholder present and entitled to vote may vote in person or by attorney, proxy or representative;
 - (ii) has one vote on a show of hands; and
 - (iii) has one vote for every Share held, upon a poll.
- (c) **(Dividend rights):** Shareholders will be entitled to dividends, distributed among members in proportion to the capital paid up, from the date of payment. No dividend carries interest against the Company and the declaration of Directors as to the amount to be distributed is conclusive.

Shareholders may be paid interim dividends or bonuses at the discretion of the Directors. The Company must not pay a dividend unless the Company's assets exceed its liabilities immediately before the dividend is declared and the excess is sufficient for the payment of the dividend.

- (d) **(Variation of rights):** The rights attaching to the Shares may only be varied by the consent in writing of the holders of three-quarters of the Shares, or with the sanction of a special resolution passed at a general meeting.
- (e) **(Transfer of Shares):** Shares can be transferred upon delivery of a proper instrument of transfer to the Company or by a transfer in accordance with the ASX Settlement Operating Rules. The instrument of transfer must be in writing, in the approved form, and signed by the transferor and the transferee. Until the transferee has been registered, the transferor is deemed to remain the holder, even after signing the instrument of transfer.

8.1 RIGHTS ATTACHING TO SHARES (CONTINUED)

In some circumstances, the Directors may refuse to register a transfer if upon registration the transferee will hold less than a marketable parcel. The Board may refuse to register a transfer of Shares upon which the Company has a lien.

- (f) **(General meetings)**: Shareholders are entitled to be present in person, or by proxy, attorney or representative to attend and vote at general meetings of the Company.

The Directors may convene a general meeting at their discretion. General meetings shall also be convened on requisition as provided for by the Corporations Act.

- (g) **(Unmarketable parcels)**: The Company's Constitution provides for the sale of unmarketable parcels subject to any applicable laws and provided a notice is given to the minority Shareholders stating that the Company intends to sell their relevant Shares unless an exemption notice is received by a specified date.
- (h) **(Rights on winding up)**: If the Company is wound up, the liquidator may with the sanction of special resolution, divide the assets of the Company amongst members as the liquidator sees fit. If the assets are insufficient to repay the whole of the paid-up capital of members, they will be distributed in such a way that the losses borne by members are in proportion to the capital paid up.

8.2 TERMS AND CONDITIONS OF METALS X OPTIONS AND LEAD MANAGER OPTIONS

The Metals X Options and the Lead Manager Options (together in this Section 8.2 referred to as Options) will be granted on the following terms and conditions:

- (a) Each Option entitles the holder of the Option (**Holder**) to subscribe for one fully paid ordinary share in the Company (**Share**) on payment of the exercise price of the Option (**Exercise Price**). The Exercise Prices are:
- (i) \$0.25 for each Metals X Option; and
 - (ii) \$0.30 for each Lead Manager Option.
- (b) The Holder is not required to pay any amount on the grant of an Option.
- (c) Each Option may be exercised at any time during the period (Exercise Period) after the Company is admitted to the official list of ASX and before 5.00pm (WST) on or before the date 3 years after the date of grant of the Options (**Expiry Date**).
- (d) Any Option not exercised by the Expiry Date will automatically expire.
- (e) The Company must give the Holder a certificate or holding statement stating:
- (i) the number of Options issued to the Holder;
 - (ii) the Exercise Price of the Options; and
 - (iii) the Expiry Date of the Options.
- (f) To exercise Options, the Holder must give the Company or its share registry, at the same time:
- (i) a written exercise notice (in the form approved by the board of the Company from time to time) specifying the number of Options being exercised and Shares to be issued (**Notice of Exercise**);
 - (ii) payment of the Exercise Price for the Shares, the subject of the exercise notice, by way of bank cheque or by other means of payment, approved by the Company; and
 - (iii) any certificate for the Options.
- (g) The Holder may only exercise Options in multiples of 10,000 Options unless the Holder exercises all Options held by the Holder.
- (h) Options will be deemed to have been exercised on the date the exercise notice and Exercise Price are received by the Company.
- (i) If the Holder exercises less than the total number of Options registered in the Holder's name:
- (i) the Holder must surrender their Option certificate (if any); and
 - (ii) the Company must cancel the Option certificate (if any) and issue the Holder a new Option certificate or holding statement stating the remaining number of Options held by the Holder.

- (j) Within twenty (20) business days after the later of the following:
- (i) receipt of a Notice of Exercise given in accordance with these terms and conditions and payment of the Exercise Price for each Option being exercised; and
 - (ii) when excluded information in respect of the Company (as defined in section 708A(7) of the Corporations Act) (if any) ceases to be excluded information. If there is no such information, the relevant date will be the date of receipt of a Notice of Exercise as detailed in paragraph (i) above, the Company will:
 - (iii) allot and issue the Shares pursuant to the exercise of the Options;
 - (iv) as soon as reasonably practicable and if required, give ASX a notice that complies with section 708A(5)(e) of the Corporations Act, or, if the Company is unable to issue such a notice, lodge with ASIC a prospectus prepared in accordance with the Corporations Act and do all such things necessary to satisfy section 708A(11) of the Corporations Act to ensure that an offer for sale of the Shares does not require disclosure to investors; and
 - (v) apply for official quotation on ASX of Shares issued pursuant to the exercise of the Options.
- (k) Shares issued on the exercise of the Options rank equally with all existing Shares.
- (l) The Company will not apply to ASX for quotation of Options.
- (m) Options are transferable, subject to Applicable Law.
- (n) Subject to Applicable Law, the Holder may transfer some or all of the Options at any time before the Expiry Date by:
- (i) a proper ASTC regulated transfer (as defined in the Corporations Act) or any other method permitted by the Corporations Act; or
 - (ii) a prescribed instrument of transfer.
- (o) An instrument of transfer of an Option must be:
- (i) in writing;
 - (ii) in any usual form or in any other form approved by the Directors that is otherwise permitted by law;
 - (iii) subject to the Corporations Act, executed by or on behalf of the transferor, and if required by the Company, the transferee; and
 - (iv) delivered to the Company, at the place where the Company's register of option holders is kept, together with the certificate (if any) of the Option to be transferred and any other evidence as the Directors require to prove the title of the transferor to that Option, the right of the transferor to transfer that Option and the proper execution of the instrument of transfer.
- (p) If there is a reorganisation (including consolidation, sub-division, reduction or return) of the share capital of the Company, then the rights of the Holder (including the number of Options to which the Holder is entitled to and the Exercise Price) will be changed to the extent necessary to comply with the Listing Rules applying to a reorganisation of capital at the time of the reorganisation.
- (q) Any calculations or adjustments which are required to be made will be made by the Directors and will, in the absence of manifest error, be final and conclusive and binding on the Company and the Holder.
- (r) The Company must, within a reasonable period, give to the Holder notice of any change to the Exercise Price of any Options held by the Holder or the number of Shares which the Holder is entitled to subscribe for on exercise of an Option.
- (s) If the Company makes a bonus issue of Shares or other securities to existing Shareholders (other than an issue in lieu or in satisfaction, of dividends or by way of dividend reinvestment):
- (i) the number of Shares which must be issued on the exercise of an Option will be increased by the number of Shares which the Holder would have received if the Holder had exercised the Option before the record date for the bonus issue; and
 - (ii) no change will be made to the Exercise Price.

8.2 TERMS AND CONDITIONS OF METALS X OPTIONS AND LEAD MANAGER OPTIONS (CONTINUED)

- (t) The Holder of Options is not entitled to:
- (i) notice of, or to vote or attend at, a meeting of Shareholders;
 - (ii) receive any dividends declared by the Company; or
 - (iii) participate in any new issues of securities offered to Shareholders during the term of the Options,
- unless and until the Options are exercised and the Holder holds Shares.
- (u) These terms and the rights and obligations of the Holder are governed by the laws of Western Australia.
- (v) The Holder irrevocably and unconditionally submits to the non-exclusive jurisdiction of the courts of Western Australia in this respect.
- (w) In the terms of the Options, "Applicable Law" means the Corporations Act, the Listing Rules of ASX, the constitution of the Company and the requirements of any restriction agreement entered into by the Holder in accordance with the Listing Rules in respect of the Options.

8.3 TERMS AND CONDITIONS OF DIRECTOR OPTIONS

The following terms and conditions apply to each of the Director Options, (in this Section 8.3 referred to as the **Options**):

- (a) Options are granted to the Directors as participants in the Employee Incentive Plan (**Plan**) of Company. The Options are issued under and in accordance with the Plan and the terms and conditions of these Options are subject to the rules of the Plan
- (b) Each Option entitles the holder of the Option (**Holder**) to subscribe for one fully paid ordinary share in the Company (Share) on payment of the exercise price of \$0.20 per Options (**Exercise Price**).
- (c) The Holder is not required to pay any amount on the grant of an Option.
- (d) An Option will only vest and be exercisable if the Company is admitted to the official list of ASX.
- (e) Each vested Option may be exercised at any time during the period (**Exercise Period**) after the Company is admitted to the official list of ASX and before 5.00pm (WST) on or before the date 3 years after the date of grant of the Options (**Expiry Date**).
- (f) Any Option not exercised by the Expiry Date will automatically expire.
- (g) If the Holder is prohibited from exercising Options under Applicable Law on or in the ten (10) business days before the Expiry Date, the Expiry Date for the Options is automatically extended to the date that is five (5) business days after the Holder is no longer prohibited under Applicable Law from exercising the Option.
- (h) The Company must give the Holder a certificate or holding statement stating:
 - (i) the number of Options issued to the Holder;
 - (ii) the Exercise Price of the Options; and
 - (iii) the Expiry Date of the Options.
- (i) To exercise Options, the Holder must give the Company or its share registry, at the same time:
 - (i) a written exercise notice (in the form approved by the board of the Company from time to time) specifying the number of Options being exercised and Shares to be issued (**Notice of Exercise**);
 - (ii) payment of the Exercise Price for the Shares, the subject of the exercise notice, by way of bank cheque or by other means of payment, approved by the Company; and
 - (iii) any certificate for the Options.
- (j) The Holder may only exercise Options in multiples of 10,000 Options unless the Holder exercises all Options held by the Holder.
- (k) Options will be deemed to have been exercised on the date the exercise notice and Exercise Price are received by the Company.

- (l) If the Holder exercises less than the total number of Options registered in the Holder's name:
- (i) the Holder must surrender their Option certificate (if any); and
 - (ii) the Company must cancel the Option certificate (if any) and issue the Holder a new Option certificate or holding statement stating the remaining number of Options held by the Holder.
- (m) The Company must within twenty (20) business days after the later of the following:
- (i) receipt of a Notice of Exercise given in accordance with these terms and conditions and payment of the Exercise Price for each Option being exercised; and
 - (ii) when excluded information in respect of the Company (as defined in section 708A(7) of the Corporations Act) (if any) ceases to be excluded information. If there is no such information, the relevant date will be the date of receipt of a Notice of Exercise as detailed in paragraph (i) above, the Company will:
 - (iii) allot and issue the Shares pursuant to the exercise of the Options;
 - (iv) as soon as reasonably practicable and if required, give ASX a notice that complies with section 708A(5)(e) of the Corporations Act, or, if the Company is unable to issue such a notice, lodge with ASIC a prospectus prepared in accordance with the Corporations Act and do all such things necessary to satisfy section 708A(11) of the Corporations Act to ensure that an offer for sale of the Shares does not require disclosure to investors; and
 - (v) apply for official quotation on ASX of Shares issued pursuant to the exercise of the Options.
- (n) Notwithstanding paragraph (m) above, the Company's obligation to issue such Shares shall be postponed if such Holder at any time after the delivery of a Notice of Exercise and payment of the Exercise Price for each Option being exercised (if applicable) elects for the Shares to be issued to be subject to a holding lock for a period of twelve (12) months. Following any such election:
- (i) the Shares to be issued or transferred will be held by such Holder on the Company's issuer sponsored sub-register (and not in a CHESS sponsored holding);
 - (ii) the Company will apply a holding lock on the Shares to be issued or transferred and such Holder is taken to have agreed to that application of that holding lock; and
- (o) The Company shall release the holding lock on the Shares on the earlier to occur of:
- (i) the date that is twelve (12) months from the date of issue of the Share; or
 - (ii) the date the Company issues a disclosure document that qualifies the Shares for trading in accordance with section 708A(11) of the Corporations Act; or
 - (iii) the date a transfer of the Shares occurs pursuant to paragraph (p) of these terms and conditions.
- (p) Shares shall be transferable by such Holder and the holding lock will be lifted provided that the transfer of the Share complies with section 707(3) of the Corporations Act and, if requested by the Company, the transferee of the Shares agrees by way of a deed poll in favour of the Company to the holding lock applying to the Shares following its transfer for the balance of the period in paragraph (o).
- (q) Shares issued on the exercise of the Options rank equally with all existing Shares.
- (r) The Company will not apply to ASX for quotation of Options.
- (s) Options may not be assigned, transferred, encumbered with a Security Interest in or over them, or otherwise disposed of by the Holder, unless:
- (i) the prior consent of the Board is obtained, which consent may impose such terms and conditions on such assignment, transfer, encumbrance with a Security Interest or disposal as the Board sees fit; or
 - (ii) such assignment or transfer occurs by force of law upon the death or total and permanent disablement of the Holder to the Holder's legal personal representative.
- (t) If there is a reorganisation (including consolidation, sub-division, reduction or return) of the share capital of the Company, then the rights of the Holder (including the number of Options to which the Holder is entitled to and the Exercise Price) will be changed to the extent necessary to comply with the Listing Rules applying to a reorganisation of capital at the time of the reorganisation.

8.3 TERMS AND CONDITIONS OF DIRECTOR OPTIONS (CONTINUED)

- (u) Any calculations or adjustments which are required to be made will be made by the Directors and will, in the absence of manifest error, be final and conclusive and binding on the Company and the Holder.
- (v) The Company must, within a reasonable period, give to the Holder notice of any change to the Exercise Price of any Options held by the Holder or the number of Shares which the Holder is entitled to subscribe for on exercise of an Option.
- (w) If the Company makes a bonus issue of Shares or other securities to existing Shareholders (other than an issue in lieu or in satisfaction, of dividends or by way of dividend reinvestment):
 - (i) the number of Shares which must be issued on the exercise of an Option will be increased by the number of Shares which the Holder would have received if the Holder had exercised the Option before the record date for the bonus issue; and
 - (ii) no change will be made to the Exercise Price.
- (x) The Holder of Options is not entitled to:
 - (i) notice of, or to vote or attend at, a meeting of Shareholders;
 - (ii) receive any dividends declared by the Company; or
 - (iii) participate in any new issues of securities offered to Shareholders during the term of the Options,

unless and until the Options are exercised and the Holder holds Shares.
- (y) These terms and the rights and obligations of the Holder are governed by the laws of Western Australia. The Holder irrevocably and unconditionally submits to the non-exclusive jurisdiction of the courts of Western Australia in this respect.
- (z) In the terms of the Options:
 - (i) "Applicable Law" means the Corporations Act, the Listing Rules of ASX, the constitution of the Company and the requirements of any restriction agreement entered into by the Holder in accordance with the Listing Rules in respect of the Options; and
 - (ii) expressions that are defined in the Rules have the meaning given to them in the Rules.

8.4 EMPLOYEE INCENTIVE PLAN

The Company has established an Employee Incentive Plan (Plan).

The terms and operation of the Plan are summarised below. A copy of the rules of the Plan may be inspected at the registered office of the Company during normal business hours.

- (a) **(Purpose):** The purpose of the Plan is to:
 - (i) assist in the reward, retention and motivation of Eligible Employees (as defined below);
 - (ii) link the reward of Eligible Employees to Shareholder value creation; and
 - (iii) align the interests of Eligible Employees with Shareholders, by providing an opportunity to Eligible Employees to receive an equity interest in the Company.
- (b) **(Eligible participant):** "Eligible Employees" may participate in the Plan at the discretion and determination of the Board. An "Eligible Employee" for the purposes of the Plan means:
 - (i) Directors and employees, consultants or contractors of the Company or any Group Company who are declared by the Board to be eligible to receive grants of "Employee Incentives" under the Plan; and
 - (ii) any other person who is declared by the Board to be eligible to receive grants of "Employee Incentives".

An Eligible Employee who participates in the Plan is a "Participant".

- (c) **(Employee Incentives):** The Plan provides for the offer or grant of "Employee Incentives" being Shares, Options or performance rights issued or granted by the Company and Shares issued on the exercise of Options or the conversion of a performance right.

For personal use only

- (d) **(Maximum allocation):** The Company must not make an offer of Employee Incentives under the Plan where the total number of Shares that may be issued, or acquired upon exercise of Options or performance rights, when aggregated with the number of Shares issued or that may be issued as a result of offers made under the Plan at any time during the previous 3-year period would exceed 10% of the total number of Shares on issue at the date of the offer.
- (e) **(Plan administration):** The Plan will be administered by the Board. The Board may exercise any power or discretion conferred on it by the Plan rules in its sole and absolute discretion. The Board may delegate its powers and discretion.
- (f) **(Eligibility, invitation and application):** The Board may from time to time determine that an Eligible Employee may participate in the Plan and make an offer to that Eligible Employee to apply for Employee Incentives on such terms and conditions as the Board decides.
- On receipt of an application, an Eligible Employee may apply for the Employee Incentives the subject of the offer by sending a completed application form to the Company. The Board may accept an application from an Eligible Employee in whole or in part. An Eligible Employee may nominate a related party of the Eligible Employee to be issued or granted the Employee Incentives if so permitted by the terms of the offer.
- (g) **(Grant of Employee Incentives):** The Company will, to the extent that it has accepted a duly completed application, grant the Eligible Employee the relevant number of Employee Incentives, subject to the terms and conditions set out in the offer, the Plan rules and any ancillary documentation required.
- (h) **(Possible vesting and performance conditions):** Employee Incentives issued/granted under the Plan may be subject to vesting conditions set in the offer of the Employee Incentives, as determined by the Board. These are conditions which must be satisfied or waived before the Employee Incentives can vest or can be exercised (if applicable). They may be time-based criteria or performance-based criteria.
- (i) **(Possible restrictions on disposal):** Employee Incentives issued/granted under the Plan and any resulting Shares, may be subject to restrictions on sale or disposal, as determined by the Board.
- (j) **(ASIC relief)** In accordance with ASIC Class Order 14/1000, after Admission, the total number of Shares that may be issued/granted under the Plan will not exceed 5% of the total number of Shares on issue. In calculating this limit, Employee Incentives issued/granted under the Plan other than in reliance upon this Class Order are not included in the limit.
- (k) **(Forfeiture of Employee Incentives):** At the discretion of the Board, a Participant may forfeit any Employee Incentives in various circumstances including where the Participant acts fraudulently or dishonestly, breaches his or her duties to the Company, commits a material breach of their employment contract, is charged with or convicted of a criminal offence or commits serious misconduct or accepts a position to work with a competitor of the Company.
- Unless the Board otherwise determines, where a person commits an action of the type described above and ceases to be an employee or officer of the Company (and becomes a “Bad Leave” as defined under the Plan) any Employee Incentives (vested or unvested) will be forfeited immediately.
- (l) **(Vesting of change of control):** If a change of control event occurs in relation to the Company, the Options or performance rights granted under the Plan which are subject to vesting conditions may automatically vest regardless of whether any performance criteria or vesting conditions have been satisfied.
- (m) **(Rights attaching to Plan Shares):** All Shares issued under the Plan, or issued or transferred to a Participant upon the valid exercise of a Convertible Security, (Plan Shares) will rank pari passu in all respects with all other Shares on issue.
- (n) **(Taxation deferral):** The Plan provides for the issue of Equity Securities in circumstances where income tax otherwise payable by a Participant on the value of Options or performance rights granted under the Plan may be deferred in accordance with the provisions of subdivision 83A-C of the *Income Tax Assessment Act 1997* (Cth).
- (o) **(Participation in new issues):** There are no participation rights or entitlements inherent in Options or performance rights granted under the Plan and holders are not entitled to participate in any new issue of Shares of the Company during the currency of Options or performance rights granted under the Plan without exercising the Options or performance rights.

8.4 EMPLOYEE INCENTIVE PLAN (CONTINUED)

- (p) **(Amendment of Plan):** Subject to the following paragraph, the Board may at any time amend any provisions of the Plan rules, including (without limitation) the terms and conditions upon which any Employee Incentives have been granted under the Plan and determine that any amendments to the Plan rules be given retrospective effect, immediate effect or future effect.

No amendment to any provision of the Plan rules may be made if the amendment materially reduces the rights of any Participant as they existed before the date of the amendment, other than an amendment introduced primarily for the purpose of complying with legislation or to correct manifest error or mistake, amongst other things, or is agreed to in writing by Participants.

- (q) **(Plan duration):** The Plan continues in operation until the Board decides to end it. The Board may from time to time terminate or suspend the operation of the Plan for such period as it thinks fit.

8.5 MAXIMUM NUMBER OF EQUITY SECURITIES THAT MAY BE ISSUED UNDER THE EMPLOYEE INCENTIVE PLAN

For the purposes of the Listing Rule 7.2 Exception 13(a), the Company states that the maximum number of securities proposed to be issued under the Employee Incentive Plan within the three-year period from the Prospectus Date is 8,100,000 Equity Securities, representing 10% of the Shares in the Company proposed to be on issue at the time of the Company's admission to ASX.

The stated maximum number is not intended to be a prediction of, or a fixed limit to, the actual number of securities to be issued under the Plan but is a stated maximum number for the purposes of the operation of Listing Rule 7.2 Exception 13(a) if the Company is admitted to ASX.

Listing Rule 7.1 limits the number of securities a listed company may issue in any 12-month period without shareholder approval. However, securities issued pursuant to an exception to Listing Rule 7.1 are not counted for the purposes of the limit. Listing Rule 7.2 Exception 13(a) provides that Equity Securities issued under the Plan within 3 years of the Prospectus Date not exceeding the maximum number stated in this Prospectus will be an exception to Listing Rule 7.1.

8.6 INTERESTS OF PROMOTERS, EXPERTS AND ADVISERS

(A) NO INTEREST EXCEPT AS DISCLOSED

Other than as set out below or elsewhere in this Prospectus, no persons or entity named in this Prospectus as performing a function in a professional, advisory or other capacity in connection with the preparation or distribution of this Prospectus holds at the Prospectus Date, or held at any time during the last 2 years, any interest in:

- (i) the formation or promotion of the Company;
- (ii) property acquired or proposed to be acquired by the Company in connection with its formation or promotion, or the Offers; or
- (iii) the Offers,

and the Company has not paid any amount or provided any benefit, or agreed to do so, to any of those persons for services rendered by them in connection with the formation or promotion of the Company or the Public Offer.

(B) SHARE REGISTRY

Computershare Investor Services Pty Limited (trading as Computershare) has been appointed to conduct the Company's share registry functions and to provide administrative services in respect to the processing of Applications received pursuant to this Prospectus, and will be paid for these services on standard industry terms and conditions.

(C) AUDITOR

Criterion Audit Pty Ltd has been appointed to act as auditor to the Company. The Company has paid a fee of \$13,000 (excluding GST) for services in connection with the audited accounts of the Company for the year ended 30 June 2021.

(D) INVESTIGATING ACCOUNTANT

Criterion Audit Pty Ltd has acted as Investigating Accountant and has prepared the Investigating Accountant's Report which is included in Schedule 1 of this Prospectus. The Company estimates it will pay Criterion Audit Pty Ltd a total of \$5,000 (excluding GST) for these services. During the 24 months preceding lodgement of this Prospectus with ASIC, Criterion Audit Pty Ltd has not provided any other services to the Company, other than the audit services mentioned in Section 8.6(c).

(E) INDEPENDENT GEOLOGIST

CSA Global Pty Ltd has acted as Independent Geologist and has prepared the Independent Technical Assessment Report which is included in Schedule 3 of this Prospectus. The Company estimates it will pay CSA Global Pty Ltd a total of \$36,700 (excluding GST) for these services. During the 24 months preceding lodgement of this Prospectus with ASIC, CSA Global Industry Consultants Pty has not provided any other services to the Company.

(F) SOLICITORS

Blackwall legal LLP has acted as the Solicitors to the Company in relation to the Public Offer and has prepared the Solicitors' Report which is included in Schedule 2 of this Prospectus. The Company estimates it will pay Blackwall legal LLP a total of \$85,000 (excluding GST) for these services. During the 24 months preceding lodgement of this Prospectus with ASIC, Blackwall legal LLP has provided other legal services to the Company, for which it has been paid or is entitled to be paid an amount of \$75,000 (excluding GST).

(G) LEAD MANAGERS

Blue Ocean Equities and Marketech Online Trading are acting as lead managers to the Public Offer and are entitled to be paid fees in accordance with the Lead Manager Mandate summarised in Section 7.4. During the 24 months preceding lodgement of this Prospectus with ASIC, the Lead Managers have not provided any other services to the Company.

8.7 CONSENT STATEMENTS

Each of the parties referred to in this Section:

- (a) does not make, or purport to make, any statement in this Prospectus other than those referred to in this Section;
- (b) only to the maximum extent permitted by law, expressly disclaims and take no responsibility for any part of this Prospectus other than a reference to its name and a statement included in this Prospectus with the consent of that party as specified in this Section; and
- (c) has given and has not, prior to the lodgement of this Prospectus with ASIC, withdrawn its consent to the inclusion of the statements in this Prospectus that are specified below in the form and context in which the statements appear.

Computershare Investor Services Pty Limited (trading as Computershare) has given, and has not withdrawn prior to the lodgement of this Prospectus with ASIC, its written consent to being named in this Prospectus as Share Registry of the Company in the form and context in which it is named.

Criterion Audit Pty Ltd has given, and has not withdrawn prior to the lodgement of this Prospectus with ASIC, its written consent to being named in this Prospectus as auditor of the Company in the form and context in which it is named and to the inclusion of financial information from the audited financial statements of the Company and Metals Exploration Pty Ltd in the form and context in which it is included.

Criterion Audit Pty Ltd has given, and has not withdrawn prior to the lodgement of this Prospectus with ASIC, its written consent to being named in this Prospectus as the Investigating Accountant to the Company in the form and context in which it is named and has given and not withdrawn its consent to the inclusion of the Investigating Accountant's Report in the form and context in which it is included.

CSA Global Pty Ltd has given, and has not withdrawn prior to the lodgement of this Prospectus with ASIC, its written consent to being named in this Prospectus as the Independent Geologist to the Company in the form and context in which it is named and has given and not withdrawn its consent to the inclusion of the Independent Technical Assessment Report in the form and context in which it is included.

8.7 CONSENT STATEMENTS (CONTINUED)

Blackwall legal LLP has given, and has not withdrawn prior to the lodgement of this Prospectus with ASIC, its written consent to being named in this Prospectus as the Solicitors to the Company in the form and context in which it is named and has given and not withdrawn its consent to the inclusion of the Solicitors' Report in the form and context in which it is included.

Blue Ocean Equities Pty Ltd and Marketech Online Trading Pty Ltd have given, and have not withdrawn prior to the lodgement of this Prospectus with ASIC, their written consents to being named in this Prospectus as the lead managers to the Public Offer in the form and context in which they are named.

Metals X has given, and has not withdrawn prior to the lodgement of this Prospectus with ASIC, its written consents to the inclusion in the Independent Technical Assessment Report contained in this Prospectus of statements taken from and references to its internal reports and information memorandum entitled "Nickel Division Annual Mineral Resource Commentary June 2016", "Nickel Division Annual Mineral Resource Commentary June 2017", "Austral Nickel Pty Ltd Annual Technical Report Exploration Conducted on Exploration Licence: 5860 "Claude Hills" for the Period Ending 19 June 2018" and "Information Memorandum Central Musgrave (Wingellina) Nickel-Cobalt Project 15 February 2019" in the form and context in which they are included in the Independent Technical Assessment Report".

8.8 EXPENSES OF PUBLIC OFFER

The total approximate expenses of the Offers payable (inclusive of GST) by the Company are:

Items of expenditure	Minimum Subscription (\$)	Maximum Subscription (\$)
ASIC lodgement fee	3,200	3,200
ASX Lodgement fee	5,500	5,500
ASX quotation fee	92,088	94,503
Legal fees	93,500	93,500
Share registry fees	3,300	3,300
Auditing Fees	14,300	14,300
Investigating Accountant fees	5,500	5,500
Independent Geologist fees	40,370	40,370
Tenement transfer fees and stamp duty	260,000	260,000
Capital raising fees ¹	401,500	533,500
Printing, postage and administration fees	8,800	8,800
TOTAL	928,058	1,062,473

8.9 CONTINUOUS DISCLOSURE OBLIGATIONS

Following Admission, the Company will be a "disclosing entity" (as defined in section 111AC of the Corporations Act) and, as such, will be subject to regular reporting and disclosure obligations. Specifically, like all listed companies, the Company will be required to continuously disclose any information it has to the market which a reasonable person would expect to have a material effect on the price or the value of the Shares (unless a relevant exception to disclosure applies). Price sensitive information will be publicly released through ASX before it is otherwise disclosed to Shareholders and market participants. Distribution of other information to Shareholders and market participants will also be managed through disclosure to ASX. In addition, the Company will post this information on its website after ASX confirms that an announcement has been made, with the aim of making the information readily accessible to the widest audience.

8.10 LITIGATION

So far as the Directors are aware, there is no current or threatened civil litigation, arbitration proceedings or administrative appeals, or criminal or governmental prosecutions of a material nature in which the Company is directly or indirectly concerned which is likely to have a material adverse effect on the business or financial position of the Company.

For personal use only

8.11 ELECTRONIC PROSPECTUS

Pursuant to Regulatory Guide 107 ASIC has exempted compliance with certain provisions of the Corporations Act to allow distribution of an Electronic Prospectus on the basis of a paper Prospectus lodged with ASIC and the issue of Shares in response to an electronic application form, subject to compliance with certain provisions. If you have received this Prospectus as an Electronic Prospectus, please ensure that you have received the entire Prospectus accompanied by the Application Form. If you have not, please email the Company and the Company will send to you, for free, either a hard copy or a further electronic copy of this Prospectus or both.

The Company reserves the right not to accept an Application Form from a person if it has reason to believe that when that person was given access to the electronic Application Form, it was not provided together with the Electronic Prospectus and any relevant supplementary or replacement prospectus or any of those documents were incomplete or altered. In such a case, the Application Monies received will be dealt with in accordance with section 722 of the Corporations Act.

8.12 DOCUMENTS AVAILABLE FOR INSPECTION

Copies of the following documents are available for inspection during normal business hours at the registered office of the Company:

- (a) this Prospectus;
- (b) the Constitution; and
- (c) the consents referred to in Section 8.6 of this Prospectus.

8.13 STATEMENT OF DIRECTORS

The Directors report that after due enquiries by them, in their opinion, since the date of the financial statements in the Investigating Accountant's Report in Schedule 1, there have not been any circumstances that have arisen or that have materially affected or will materially affect the assets and liabilities, financial position, profits or losses or prospects of the Company, other than as disclosed in this Prospectus.

09. Authorisation

The Prospectus is issued by the Company and its issue has been authorised by a resolution of the Directors.

In accordance with section 720 of the Corporations Act, each Director has consented to the lodgement of this Prospectus with ASIC and has not withdrawn that consent.

This Prospectus is signed for and on behalf of the Company by:



Roderick Corps
Managing Director

Dated: 23 November 2021

10. Glossary of Terms

10.1 DEFINED TERMS AND EXPRESSIONS

In this Prospectus the following terms have the following meanings:

Term	Definition
A\$ or \$	Australian dollars.
AAS	The Australian Accounting Standards adopted by the Australian Accounting Standards Board.
Acquisition	The acquisition by the Company of 100% of the shares in Metals Exploration from Metals X pursuant to the Share Sale Agreement in consideration for the issue of 25,000,000 Shares to Metals X.
Admission	The admission of the Company to the Official List, following completion of the Offers.
AIG	Australian Institute of Geoscientists.
Applicant	A person who submits an Application Form.
Application	A valid application for Securities pursuant to this Prospectus.
Application Form	The IPO Application Form, or an application form accompanying this Prospectus.
Application Monies	Application monies for Shares under the Public Offer received and banked by the Company.
APY	The Anangu Pitjantjatjara Yankunytjatjara, the body corporate constituted under this name by the <i>Anangu Pitjantjatjara Yankunytjatjara Land Rights Act 1981 (SA)</i> .
ASIC	The Australian Securities and Investments Commission.
Associate	Has the meaning given to that term in sections 10 to 17 of the Corporations Act.
ASX	ASX Limited ACN 008 624 691 or, where the context requires, the financial market operated by it.
ASX Recommendations	The 4th edition of the ASX Corporate Governance Council's Corporate Governance Principles and Recommendations.
ASX Settlement	ASX Settlement Pty Limited ACN 008 504 532.

Term	Definition
ASX Settlement Rules	ASX Settlement Operating Rules of ASX Settlement.
Auditor	The Company's auditor, Criterion Audit Pty Ltd ACN 165 181 822.
AusIMM	Australasian Institute of Mining and Metallurgy.
Austral Nickel	Austral Nickel Pty Ltd ACN 092 816 558, a subsidiary of Metals Exploration and the holder of the Claude Hills Project.
Blue Ocean Equities	Blue Ocean Equities Pty Ltd ACN 151 186 935.
Board	The board of Directors of the Company as at the Prospectus Date.
CHESS	The Clearing House Electronic Sub-register System operated by ASX Settlement.
Claude Hills Project	The Tenements comprising EL5860 and EL6240.
Closing Date	The date that the Public Offer closes which is 5.00pm (WST) on 17 December 2021 or such other time and date as the Board determines.
CMP Project	The Central Musgrave Project, comprising the Wingellina Nickel Cobalt Project and the Claude Hills Project as described in Section 3.4.
Company	NICO Resources Limited ACN 649 817 425.
Company Secretary	The secretary of the Company.
Competent Person	Has the meaning given to that term in the JORC Code.
Consideration Shares	25,000,000 Shares to be issued to or at the direction of Metals X as consideration for the Acquisition.
Constitution	The constitution of the Company.
Corporations Act	The <i>Corporations Act 2001</i> (Cth).
Director Options	The 9,000,000 Options issued to the Directors on the terms and conditions set out in Section 8.3.
Directors	The directors of the Company.
Distribution	The pro rata distribution in-specie of 25,000,000 Shares (to be issued to Metals X or its nominee as consideration of the Acquisition) to Eligible Metals X Shareholders.
Distribution Offer	The offer and issue of Shares under the Distribution to Eligible Metals X Shareholders and to the Sale Agent in respect of Metals X Shareholders who are Ineligible Overseas Shareholders.
Distribution Shares	25,000,000 Shares to be issued to Metals X as consideration for the Acquisition.
Electronic Prospectus	The electronic copy of this Prospectus located at the Company's website www.nicoresources.com.au .
Eligible Countries	Australia, Hong Kong, New Zealand, Peoples Republic of China and the United Kingdom, and such other jurisdictions as the Metals X Directors consider reasonable to extend the Distribution to.
Eligible Metals X Shareholder	A Metals X Shareholder with a registered address in an Eligible Country, registered as a holder of Metals X Shares on the Record Date.
EPA	The Western Australian Environmental Protection Authority.
Equity Security	Has the meaning given to the term "equity security" in the Listing Rules, and includes shares, options and convertible securities issued by a listed entity.
Executive Director	An executive Director of the Company.
Existing Options	Options granted as at the Prospectus Date.
Existing Shares	Shares issued as at the Prospectus Date.
Existing Shareholders	Holders of Shares at the Prospectus Date.
Exploration Result	Has the meaning given to that term in the JORC Code.

Term	Definition
Exposure Period	The period of 7 days after the date of lodgement of this Prospectus, which period may be extended by the ASIC by not more than 7 days pursuant to section 727(3) of the Corporations Act.
FATA	<i>Foreign Acquisitions and Takeovers Act 1975 (Cth).</i>
FIRB	Foreign Investment Review Board.
GST	Goods and services tax.
Hinckley Range	Hinckley Range Pty Ltd ACN 052 098 496, a subsidiary of Metals Exploration and the holder of the Wingellina Project.
IFRS	The International Financial Reporting Standards and interpretations issued by the International Accounting Standards Board.
Independent Geologist	CSA Global Pty Ltd.
Independent Technical Assessment Report	The report contained in Schedule 3 prepared by the Independent Geologist.
Indicative Timetable	The indicative timetable for the Public Offer on page 3 of this Prospectus.
Ineligible Overseas Shareholders	A Metals X Shareholder registered as a holder of Metals X Shares on the Record Date, but who is not an Eligible Metals X Shareholder.
Investigating Accountant	Criterion Audit Pty Ltd ACN 165 181 822.
Investigating Accountant's Report	The report contained in Schedule 1.
IPO Application Form	The application form accompanying this Prospectus in respect of the Public Offer.
Issue Date	The date, as determined by the Directors, on which the Securities offered under Offers are issued, which is anticipated to be the date identified in the Indicative Timetable.
JORC	The Joint Ore Reserves Committee of The Australasian Institute of Mining and Metallurgy, Australian Institute of Geoscientists and Minerals Council of Australia.
JORC Code	The Australasian Code for Reporting of Exploration Results, Mineral Resources and Ore Reserves (2012 Edition) prepared by JORC.
Lead Managers	The lead managers to the Public Offer, Blue Ocean Equities and Marketech Online Trading.
Lead Manager Mandate	The Lead Managers' mandate to act as lead managers in respect of the Public Offer as summarised in Section 7.4.
Lead Manager Options	800,000 Options to be issued to Blue Ocean Equities (or its nominees) on the terms and conditions set out in Section 8.2 in consideration for lead manager services provided to the Company.
Listing Rules	The listing rules of ASX.
Marketech Online Trading	Marketech Online Trading Pty Ltd ACN 654 674 432.
Maximum Subscription	The raising of \$12,000,000 pursuant to the Public Offer.
Metals Exploration	Metals Exploration Pty Ltd ACN 005 483 009, a subsidiary of Metals X.
Metals X or MLX	Metals X Limited ACN 110 150 055, the vendor of Metals Exploration under the Share Sale Agreement.
Metals X Directors	The directors of Metals X.

Term	Definition
Metals X General Meeting	The general meeting of Metals X Shareholders convened by the Metals X Notice of Meeting to approve the Distribution.
Metals X Notice of Meeting	The notice of general meeting issued by Metals X for the purposes of Metals X Shareholders approving the Distribution.
Metals X Options	The Options issued to Metals X on the terms and conditions set out in Section 8.2.
Metals X Shareholders	Registered holders of Metals X Shares.
Metals X Shares	Fully paid ordinary shares in Metals X.
Metex Nickel	Metex Nickel Pty Ltd ACN 108 243 358, a subsidiary of Metals Exploration.
Mineral Resources	Mineral resources within the meaning of the JORC Code.
Mines Department (WA)	The Department of Mines, Industry Regulation and Safety, Government of Western Australia.
Mines Department (SA)	The Department for Energy and Mining, Government of South Australia.
Minimum Subscription	The raising of \$10,000,000 pursuant to the Public Offer.
Mining Act (SA)	The Mining Act 1971 (SA), any amendment or statutory replacement of that Act and the regulations and orders made under that Act.
Mining Act (WA)	The Mining Act 1978 (WA), any amendment or statutory replacement of that Act and the regulations and orders made under that Act.
NICO	NICO Resources Limited ACN 649 817 425.
Non-Executive Director	A non-executive Director of the Company.
Offer Period	The period between the Opening Date and the Closing Date.
Offers	The Public Offer and/or the Distribution Offer, as the context requires.
Official List	The official list of ASX.
Official Quotation	Official quotation of the Shares by ASX in accordance with the Listing Rules.
Opening Date	The date specified as the opening date of the Public Offer in the Indicative Timetable.
Option	An option issued by the Company to acquire a Share.
Ore Reserves	Ore reserves within the meaning of the JORC Code.
Projects	The Wingellina Nickel Cobalt Project and the Claude Hills Project as described in Section 3.4.
Prospectus	This prospectus.
Prospectus Date	The date of this Prospectus
Public Offer	The offer by the Company, pursuant to this Prospectus, of a minimum of 50,000,000 Shares and up to a maximum of 60,000,000 Shares at the Public Offer Price to raise a minimum of \$10,000,000 and up to a maximum of \$12,000,000 (before costs).
Public Offer Price	\$0.20 per Share under the Public Offer.
Record Date	The record date set by Metals X for determining entitlements of Metals X Shareholders to the Distribution.
Sale Agent	Blue Ocean Equities, being the broker engaged by Metals X to receive Distribution Shares that are not distributed to Ineligible Overseas Shareholders and to sell those Shares on market for the benefit of Ineligible Overseas Shareholders.
SA	South Australia
SA Tenements	The Tenements located in South Australia.
Section	A section of this Prospectus, unless the context provides otherwise.

Term	Definition
Securities	Any securities, including Shares and Options, issued or granted by the Company.
Seed Raising	Has the meaning ascribed in Section 3.1.
Share	A fully paid ordinary share in the capital of the Company.
Share Sale Agreement	The Share Sale and Subscription Agreement between the Company and Metals X as summarised at Section 7.2 pursuant to which the Company has agreed to acquire all shares in Metals Exploration and Metals X has agreed to subscribe for 20,000,00 Shares under the Public Offer.
Share Registry	The Company's share registry, Computershare Investor Services Pty Ltd.
Shareholder	A registered holder of one or more Shares.
Solicitors	The Company's solicitors, Blackwall legal LLP.
Solicitors' Report	The report on the Tenements by the Company's solicitors, Blackwall Legal LLP, contained in Schedule 2.
Tenements	The tenements comprising the Projects as described in Section 3.4.
US\$	United States of America dollars
WA	Western Australia
WA Tenements	The Tenements located in WA.
Wingellina, Wingellina Project or Wingellina Nickel Cobalt Project	The Tenements comprising E69/535, E69/3065, L69/12, L69/19 and L69/27 and the infrastructure located on these Tenements.
WST	Western Standard Time, being the time in Perth, Western Australia.

10.2 TECHNICAL AND INDUSTRY TERMINOLOGY

The following is an explanation of the various technical and industry terms used in this Prospectus. Refer also to the glossary of terms in section 12 of the Independent Technical Assessment Report at Schedule 3 of this Prospectus.

Term	Definition
Co	Cobalt
dunite	A granular igneous rock consisting chiefly of olivine.
Fe₂O₃	Iron (III) oxide (or ferric oxide)
g	Gram(s)
gabbro	A granular igneous rock composed essentially of calcic plagioclase, a ferromagnesian mineral, and accessory minerals.
ha	Hectares
HPAL	High-pressure acid leaching, a process used to extract nickel and cobalt from laterite ore bodies.
kg	Kilograms
kg/t	Kilograms per tonne
km; km²	Kilometres; square kilometres
Kt	Thousand tonnes
limonite	A mixture of fine-grained iron oxides.
mafic	Dark silicate or igneous rock rich in magnesium and iron.
Mg	Magnesium
Mn	Manganese
Mt	Million tonnes
MW	Mega watts
Ni	Nickel
olivine	An olive-green, grey-green, or brown mineral occurring widely in basalt, peridotite, and other basic igneous rocks. It is a silicate containing varying proportions of magnesium, iron and other elements.
ppb	Parts per billion
ppm	Parts per million
RC	Reverse circulation drilling
Si	Silicon
SiO₂	Silica
t	Tonnes
TJ	Terra joules
tpa	tonnes per annum
ultramafic	Igneous rocks with very low silica and very high magnesium and iron-rich minerals.

For personal use only

Schedule 1

– Investigating
Accountant's Report

CRITERION AUDIT

Criterion Audit Pty Ltd

ABN 85 165 181 822

PO Box 233 LEEDERVILLE WA 6902

Suite 2, 642 Newcastle Street
LEEDERVILLE WA 6007

Phone: 9466 9009

12 November 2021

PRIVATE & CONFIDENTIAL

The Board of Directors
NICO Resources Limited
Level 11, 216 St Georges Terrace
PERTH WA 6000

Dear Sirs

Investigating Accountants Report ("Report") on the Historical and Pro Forma Historical Financial Information of NICO Resources Limited

Introduction

Criterion Audit Pty Ltd ("Criterion") has been engaged by NICO Resources Limited ("NICO" or the "Company") to report on the historical information of the Company for the period ended 30 June 2021 and the historical information of Metals Exploration Pty Ltd for the years ended 30 June 2019, 30 June 2020 and 30 June 2021, and Pro Forma Historical Financial Information of the Company as at 30 June 2021 for inclusion in a Prospectus of the Company dated on or around 12 November 2021, to be issued in connection with the Company's initial public offer of 50,000,000 fully paid ordinary shares ("Shares") to be issued at a price of \$0.20 per Share to raise as a minimum \$10 million (before costs) and at the discretion of the Directors, the Company may accept applications for over-subscriptions to the Public Offer for up to 10,000,000 Shares to each to raise up to \$2,000,000, with a maximum of \$12,000,000 (the "Offer"), pursuant to which the Company is seeking to list on the Australia Securities Exchange ("ASX").

Expressions and terms defined in the document have the same meaning in this Report. This Report has been prepared for inclusion in the Prospectus. We disclaim any assumption of responsibility for any reliance on this Report or on the Financial Information to which it relates for any purpose other than that for which it was prepared.

Scope

You have requested Criterion to perform a limited assurance engagement in relation to the historical and pro forma historical financial information described below and disclosed in the Prospectus.

The historical and pro forma historical financial information is presented in the Prospectus in an abbreviated form insofar as it does not include all of the presentation and disclosures required by Australian Accounting Standards and other mandatory professional reporting requirements applicable to general purpose financial reports prepared in accordance with the Corporations Act 2001.

Historical Financial Information

You have requested Criterion to review the following historical financial information (together the "Historical Financial Information") of NICO included in the Prospectus:



Liability limited by a scheme approved under Professional Standards Legislation

NICO Resources Limited
Investigating Accountant's Report

- the audited historical Statement of Profit or Loss and Other Comprehensive Income and Statement of Cash flows for the years ended 30 June 2019, 30 June 2020 and 30 June 2021 for Metals Exploration Pty Ltd and 30 June 2021 for NICO Resources Limited; and
- the audited historical Statement of Financial Position for the years ended 30 June 2019, 30 June 2020 and 30 June 2021 for Metals Exploration Pty Ltd and 30 June 2021 for NICO Resources Limited.

The Historical Financial Information has been prepared in accordance with the stated basis of preparation, being the recognition and measurement principles contained in Australian Accounting Standards and the Company's adopted accounting policies. The Historical Financial Information has been extracted from the financial reports for the period ended 30 June 2019, 30 June 2020 and 30 June 2021 which were audited by Criterion in accordance with Australian Auditing Standards. Criterion issued qualified audit opinions for 30 June 2019, 30 June 2020 and 30 June 2021 on the financial reports for Metals Exploration Pty Ltd with material uncertainty related to going concern, and an unqualified audit opinion for 30 June 2021 on the financial report of NICO Resources Pty Ltd.

Pro Forma Historical Financial Information

You have requested Criterion to review the following pro forma historical financial information (together the "Pro Forma Historical Financial Information") of NICO included in the Prospectus:

- the pro forma historical Statement of Financial Position as at 30 June 2021.

The pro forma historical financial information has been derived from the historical financial information of NICO, after adjusting for the effects of the subsequent events and pro forma adjustments described in section 5 of the Prospectus. The stated basis of preparation is the recognition and measurement principles contained in Australian Accounting Standards applied to the historical financial information and the events or transactions to which the pro forma adjustments relate, as described in section 5 of the Prospectus, as if those events or transactions had occurred as at the date of the historical financial information. Due to its nature, the pro forma historical financial information does not represent the company's actual or prospective financial position.

The pro forma historical financial information has been compiled by NICO to illustrate the impact of the events or transactions described in section 5 of the Prospectus on NICO's financial position as at 30 June 2021. As part of this process, information about NICO's financial position has been extracted by NICO from its financial statements for the period ended 30 June 2021.

The pro-forma historical financial information has been prepared by adjusting the statement of financial position of the Company as at 30 June 2021 to reflect the financial effects of the following pro forma transactions which are yet to occur, but are proposed to occur following completion of the Offer:

- (a) the issue of 25,000,000 Shares totalling \$5,000,000 to Metals X for the Acquisition;
- (b) the issue of 50,000,000 Shares at \$0.20 per Share to raise \$10,000,000 before costs (Minimum Subscription) or the issue of 60,000,000 Shares at \$0.20 per Share to raise \$12,000,000 before costs (Maximum Subscription);
- (c) capital raising costs with respect to payments to the Lead Manager are estimated to be \$396,000 based on the Minimum Subscription and \$528,000 based on the Maximum Subscription;
- (d) further costs in relation to the Offer of \$532,058 and \$534,473 respectively (Minimum and Maximum Subscriptions); and
- (e) the issue of 800,000 Lead Manager Options (with an exercise price of \$0.30 and a term of 3 years) to Blue Ocean Equities (a Lead Manager) as consideration for capital raising services provided in connection with the Offer (Minimum and Maximum Subscriptions).

Directors' Responsibility

The directors of NICO are responsible for the preparation of the historical financial information and pro forma historical financial information, including the selection and determination of pro forma adjustments made to the historical financial information and included in the pro forma historical financial information. This includes responsibility for such internal controls as the directors determine are necessary to enable the preparation of historical financial information and pro forma historical financial information that are free from material misstatement, whether due to fraud or error.

Our Responsibility

Our responsibility is to express limited assurance conclusions on the Historical Financial Information and the Pro Forma Historical Financial Information based on the procedures performed and the evidence we have obtained. We have conducted our engagement in accordance with the Standard on Assurance Engagement ASAE 3420 *Assurance Engagements to Report on the Compilation of Pro Forma Historical Financial Information included in a Prospectus or other Document*.

A review consists of making enquiries, primarily of persons responsible for financial and accounting matters, and applying analytical and other review procedures. A review is substantially less in scope than an audit conducted in accordance with Australian Auditing Standards and consequently does not enable us to obtain reasonable assurance that we would become aware of all significant matters that might be identified in an audit. Accordingly, we do not express an audit opinion.

Our engagement did not involve updating or re-issuing any previously issued audit or review report on any financial information used as a source of the financial information.

Conclusion*Historical Financial Information*

Based on our review, which is not an audit, nothing has come to our attention that causes us to believe that the historical financial information for the Company comprising:

- the Statement of Profit or Loss and Other Comprehensive Income and Statement of Cash flows for the years ended 30 June 2019 ,30 June 2020 and 30 June 2021 for Metals Exploration Pty Ltd and 30 June 2021 for Nico Resources Limited;
- the Statement of Financial Position for the years ended 30 June 2019 ,30 June 2020 and 30 June 2021 for Metals Exploration Pty Ltd and 30 June 2021 for NICO Resources Limited;

are not presented fairly, in all material respects, in accordance with the stated basis of preparation, as described in section 5 of the Prospectus

Pro Forma Historical Financial Information

Based on our review, which is not an audit, nothing has come to our attention that causes us to believe that the pro forma historical financial information for the Company comprising:

- the Statement of Financial Position as at 30 June 2021.

is not presented fairly in all material respects, in accordance with the stated basis of preparation as described in section 5 of the Prospectus.

NICO Resources Limited
Investigating Accountant's Report

Restriction on Use

Without modifying our conclusions, we draw attention to Section 6 of the Prospectus, which describes the purpose of the financial information, being for inclusion in the Prospectus. As a result, the financial information may not be suitable for use for another purpose.

Consent

Criterion has consented to the inclusion of this Investigating Accountant's Report in this disclosure document in the form and context in which it is so included (and at the date hereof, this consent has not been withdrawn), but has not authorised the issue of the disclosure document. Accordingly, Criterion makes no representation or warranties as to the completeness and accuracy of any information contained in this disclosure document other than in relation to this report, and takes no responsibility for, any other documents or material or statements in, or omissions from, this disclosure document.

Liability

The Liability of Criterion Audit Pty Ltd is limited to the inclusion of this report in the Prospectus. Criterion Audit Pty Ltd makes no representation regarding, and takes no responsibility for any other statements, or material in, or omissions from the document.

Declaration of Interest

Criterion Audit Pty Ltd does not have any interest in the outcome of this transaction or any other interest that could reasonably be regarded as being capable of affecting its ability to give an unbiased conclusion in this matter. Criterion Audit Pty Ltd will receive normal professional fees for the preparation of the report.

Yours faithfully



CHRIS WATTS ca
Director
Criterion Audit Pty Ltd

For personal use only

Schedule 2

– Solicitors’
Report



11 November 2021

The Directors
 NICO Resources Limited
 Level 11, 218 St Georges Terrace
 PERTH WA 6000

Dear Sirs

SOLICITORS' REPORT ON TENEMENTS

This report on tenements (**Report**) is prepared for inclusion in a prospectus to be dated on or about 12 November 2021 to be issued by NICO Resources Limited ACN 649 817 425 (**Company**) for the offer of a minimum of 50,000,000 shares at A\$0.20 each to raise a minimum of \$10,000,000 (**Prospectus**).

1. SCOPE AND OPINION

This report relates to mining tenements located in both Western Australia and South Australia which the Company will acquire an interest in by virtue of entering into the Share Sale Agreement (**Tenements**).

Details of the Tenements as disclosed by our searches are set out in:

- (a) Schedule 1 of this Report in respect of those Tenements applied for and granted under the *Mining Act 1978* (WA) (**WA Mining Act**), being Exploration Licences E69/535 and E69/3065 and Miscellaneous Licences L69/12, L69/19 and L69/27 (**WA Tenements**); and
- (b) Schedule 2 of this Report in respect of those Tenements applied for and granted under the *Mining Act 1971* (SA) (**SA Mining Act**), being Exploration Licences EL 5860 and EL 6240 (**SA Tenements**).

This Report also contains information regarding Aboriginal heritage, native title and other interests affecting the Tenements.

Blackwall Legal has conducted due diligence investigations on the Tenements in accordance with the instructions of the Company. This Report is limited to the scope of those investigations set out in Section 9 of this Report.

Blackwall Legal LLP ABN 53 608 771 731 is a limited liability partnership incorporated in England and Wales with registration number OC401617 and its registered office at 1721 Davenport House, 207 Regent Street London W1B 3HH. References to partners are to the designated members and other members of Blackwall Legal LLP under the *Limited Liability Partnerships Act 2000* (UK). Liability limited by a scheme approved under Professional Standards Legislation.



On the basis of our due diligence investigations on the Tenements, but subject to the statements, assumptions and qualifications set out in this Report, we consider that, as at the date of the relevant Searches, this Report provides an accurate statement as to:

- (a) the Company's interest in the Tenements;
- (b) the validity and status of the Tenements; and
- (c) nature of third party rights, interests and encroachments in relation to the Tenements.

2. ACQUISITION

2.1. Share Sale Agreement

The Company has entered into a Share Sale and Subscription Agreement dated 3 November 2021 with Metals X Limited (**MLX**) (ACN 110 150 055) (**Share Sale Agreement**) pursuant to which the Company has agreed to acquire 100% of the issued capital of Metals Exploration Pty Ltd (ACN 005 483 009) (**Metex**) from MLX (**Acquisition Shares**).

Upon completion under the Share Sale Agreement, the Company will acquire the following wholly owned subsidiaries of Metex:

- (a) Hinckley Range Pty Ltd (ACN 052 098 496) (**Hinckley Range**) which is the holder of the WA Tenements;
- (b) Austral Nickel Pty Ltd (ACN 092 816 558) (**Austral Nickel**) which is the holder of the SA Tenements; and
- (c) Metex Nickel Pty Ltd (ACN 108 243 358) (**Metex Nickel**).

A summary of the material terms and conditions of the Share Sale Agreement is contained in section 7.2 of the Prospectus.

2.2. Transfer and Title Risks

As at the date of this Report, the Company does not have a legal interest in the Tenements. However, the Company holds the exclusive right to acquire an interest in the Tenements as it has the exclusive right to acquire the Acquisition Shares pursuant to the Share Sale Agreement.

All of the Tenements have been granted. However, one of the WA Tenements, E69/535, is nearing expiry and one of the SA Tenements, EL 5860, has recently expired. Applications for renewal in respect of these two Tenements have been lodged with the relevant authorities, however no outcome has been received as at the date of this Report.



SOLICITORS' REPORT ON TENEMENTS NICO Resources Limited

In the case of E69/535, this tenement is due to expire on 22 December 2021 and is only eligible for renewal for a maximum period of 12 months upon application to the Minister. There is no guarantee that any renewal or extension will be granted upon its expiry this year or any subsequent year, however we note that the term of this tenement has previously been renewed on an annual basis on past occasions and it is not uncommon for a renewal of a tenement to be granted after expiry of its current term.

A caveat was lodged against E69/535 on 25 May 2005 by Metex Nickel. We have been informed that this caveat was lodged as a result of an historical farmin arrangement between Metex Nickel and Hinckley Range which is no longer applicable. As NICO will be acquiring Metex Nickel (as it is a wholly owned subsidiary of Metex) any risk related to the existence of this caveat is mitigated.

On the basis of the WA Searches and SA Searches, other than as set out above, we confirm that:

- (a) other than the caveat noted above, no caveats have been lodged in relation to the Tenements;
- (b) the Tenements are not subject to any registered mortgages; and
- (c) the Tenements are currently in good standing and not subject to forfeiture.

3. WA TENEMENTS

3.1. Searches

We have arranged for the following searches and enquiries to be conducted in respect of the WA Tenements for the purpose of this Report:

- (a) searches of the WA Tenements in the register maintained by the Western Australian Department of Mines, Industry Regulation and Safety (**DMIRS**) pursuant to the WA Mining Act on 4 November 2021 and key details are summarised in Part 1 of Schedule 1 of this Report;
- (b) quick appraisal user searches of the WA Tenements obtained online from the Tengraph system maintained by DMIRS on 4 November 2021 and key details are summarised in Part 2 of Schedule 1 of this Report;
- (c) searches of the Register of Native Title claims maintained by the National Native Title Tribunal (**NNTT**) on 9 November 2021 in respect of the land covered by the WA Tenements and key details are summarised in Schedule 3 of this Report;
- (d) searches of Indigenous Land Use Agreements (**ILUA**) maintained by the NNTT on 4 November 2021 in relation to those registered ILUAs which affect the WA Tenements and key details are summarised in Schedule 3 and Schedule 5 of this Report; and



- (e) searches of the Aboriginal Heritage Inquiry System (**AHIS**) obtained online from the database maintained by the Department of Planning, Lands and Heritage for Aboriginal heritage sites and heritage surveys registered over the areas of the WA Tenements on 4 November 2021 and key details are summarised in Schedule 4, Parts 1, 2 and 3 of this Report,

(WA Searches).

We have made enquiries with the Company as to all material agreements relating to the WA Tenements. Details of those provided to us by the Company for the purposes of this Report are set out in Schedule 5 of this Report.

3.2. Tenements Granted under the WA Mining Act

3.2.1. Generally

Mineral exploration and development in Western Australia (other than as amended by certain State Agreement Acts) is regulated and administered under the WA Mining Act. The WA Mining Act makes provision for the grant of a number of different tenements, including prospecting and special gold prospecting licences, exploration, retention and miscellaneous licences and mining and general purpose leases.

The WA Tenements comprise of two exploration licences and three miscellaneous licences granted under WA Mining Act.

Outlined below is a summary of the key provisions that relate to exploration licences and miscellaneous licences in Western Australia. Schedule 1 of this Report describes any exclusions, encumbrances and other specific conditions which attach to the WA Tenements.

3.2.2. Exploration Licences

Once granted, an exploration licence applied for on or after 10 February 2006 will remain in force for a period of 5 years and may, in prescribed circumstances, at the discretion of the Minister, be extended over whole or part of the exploration licence for a further period of 5 years, followed by 2-year periods.

The prescribed circumstances include where the Minister is satisfied that planned exploration could not be carried out due to delay in obtaining necessary approvals or due to the land being unworkable for at least a significant part of one year of the term, or where the Minister is satisfied that work carried out justifies further exploration.

Where an exploration licence was applied for or granted prior to 10 February 2006, once the original term and two optional renewal periods have expired, such exploration licences may only be extended in exceptional circumstances by further periods of one year each.



SOLICITORS' REPORT ON TENEMENTS
NICO Resources Limited

Exploration licences are described as graticular blocks and annual rent is charged per block. Exploration licences are also subject to minimum annual expenditure requirements.

The holder of an exploration licence applied for on or after 10 February 2006 must relinquish an area which constitutes not less than 40% of the area of the licence at the end of the 6th year of term and earlier relinquishments are not required.

No legal or equitable interest in or affecting an exploration licence can be transferred or otherwise dealt with during the first year of its term without the prior written consent of the Minister. No fee is payable for the obtaining of such consent. In determining a request for consent the Minister will consider whether the exploration programme planned for the first 12 months following grant and lodged by the tenement holder at the time of applying for the tenement has been complied with.

The WA Mining Act confers on the holder of an exploration licence which is in force, the right to apply for and, subject to the WA Mining Act, have granted one or more mining leases over any part of the land the subject of that licence. The exploration licence will continue in force beyond its term if the holder has made an application for a mining lease over the area of the licence.

Upon acquiring the Shares, the Company will hold an interest in two exploration licences, E69/535 which was applied for before 10 February 2006 and E69/3065 which was applied for after 10 February 2006.

3.2.3. Miscellaneous Licences

Miscellaneous licences are granted for infrastructure or access purposes, such as a road, pipeline or water, as prescribed in the regulations to the WA Mining Act.

Miscellaneous licences applied for on or after 10 February 2006 are granted for a term of 21 years. Upon application the Minister shall renew such a miscellaneous licence for a further 21-year period and thereafter the Minister may renew the miscellaneous licence for successive periods of 21 years. No legal interest in a miscellaneous licence can be transferred or mortgaged without the prior written consent of the Minister.

Miscellaneous licences may co-exist or overlap the same land as other mining tenements. Access agreements are common in the mining industry in Western Australia to resolve overlapping tenure issues and objections made to tenement applications. Generally, such agreements contain standard provisions relating to the management of coexisting rights of two separate parties in respect of the same area of land, where each party is exercising certain rights under its own statutory licence.

Upon acquiring the Shares, the Company will hold an interest in three miscellaneous licences, L69/12, L69/19 and L69/27 which have each been granted for the sole purpose of searching for groundwater. Any expansion beyond activities associated with the search for groundwater will need to be the subject of an appropriate miscellaneous licence.



3.2.4. Tenement Conditions and Forfeiture

Mining tenements in Western Australia are granted subject to various standard conditions prescribed by the WA Mining Act, including payment of annual rent, minimum expenditure requirements (other than for miscellaneous licences and general purposes leases), reporting requirements and standard environmental conditions, as well as any conditions that may be imposed by the Minister in respect of a particular mining tenement (such as restrictions on mining or access to certain reserves).

If a tenement holder fails to comply with the terms and conditions of a tenement, the Warden or the Minister, as applicable, may impose a fine or order that the tenement be forfeited. In most cases an order for forfeiture can only be made where the breach is of sufficient gravity to justify forfeiture of the tenement. In certain cases, a third party can institute administrative proceedings under the WA Mining Act before the Warden seeking forfeiture of the tenement.

In the case of failure to comply with the annual minimum expenditure requirement, the tenement holder can apply for an exemption from compliance with that expenditure requirement on certain grounds set out in the Mining Act or at the discretion of the Minister. A failure to comply with expenditure requirements, unless exempted, renders the tenement liable to forfeiture. In addition, a third party can object to an application for exemption for expenditure. If an exemption application is refused, then it is open to the Warden or Minister (as applicable) to impose a fine or make an order for forfeiture.

The conditions imposed on the WA Tenements as indicated from the WA Searches are set out in Schedule 1, Part 1 of this Report. We note that tenement conditions can be changed and the information contained in Schedule 1, Part 1 of this Report is accurate as at the date of the most recent WA Searches for each WA Tenement.

On the basis of our searches, we are not aware of any material non-compliance with the conditions or endorsements attaching to the WA Tenements.

Mining tenements in Western Australia are also subject to statutory requirements of certain other Acts including:

- (a) the *Aboriginal Heritage Act 1972* (**WA Heritage Act**) which is discussed in Section 6.2 of this Report; and
- (b) the *Environmental Protection Act 1986*, *Rights in Water and Irrigation Act 1914* and *Conservation and Land Management Act 1984*, the full details of which are beyond the scope of this Report.

3.2.5. Mining Rehabilitation Fund

Holders of mining leases under the WA Mining Act are required by the *Mining Rehabilitation Act 2012* (WA) to report prescribed disturbance data in relation their activities and pay a mining rehabilitation levy each year.



SOLICITORS' REPORT ON TENEMENTS NICO Resources Limited

The amount of the mining rehabilitation levy payable is calculated at 1% of the rehabilitation liability estimate of the tenement, as determined by the *Mining Rehabilitation Fund Regulations 2013* (WA). Tenements with a rehabilitation liability estimate below a threshold of \$50,000 must report disturbance data but are not required to pay a levy.

We are instructed that as at the date of this Report, no mining rehabilitation levy has been payable or paid by the Company or Hinckley Range.

3.3. Land Use and Access

Mining tenements under the WA Mining Act are exclusive only for the purposes for which they are granted and are capable of co-existing with other mining tenure, private land, pastoral and other leases, various reserves and infrastructure.

The WA Searches indicate that the WA Tenements overlap certain reserves, general leases, mining tenure and groundwater areas.

Under Western Australian and Commonwealth legislation, the Company may be required, in respect of exploration or mining activities on the Tenements, to recognise the rights of, obtain the consent of, and/or pay compensation to the holders of third-party interests which overlay areas within the WA Tenements, including other mining tenure, pastoral leases, other leases, petroleum tenure or private land. This is in addition to any legislative requirements pertaining to native title or other Aboriginal land rights or heritage.

Any delays or costs in respect of conflicting third-party rights, obtaining necessary consents, or compensation obligations, may adversely impact the Company's ability to carry out exploration or mining activities within the affected areas.

Schedule 1, Part 2 of this Report contains a summary of the types and extent of each of the various encroachments affecting the WA Tenements as identified by the WA Searches.

3.3.1. Reserves

A reserve is Crown land that has been set aside or dedicated for a particular purpose in the public interest. Reserve tenure is usually applied to land, which, because of its intrinsic community value, should be preserved and maintained for the benefit of present and future generations. This is primarily because of its recreation, historical, social, natural resources, environmental, or cultural significance, or because it has special value for present or future generations. Reserve tenure is categorised into classes and restrictions on activities in reserves vary between classes.

The WA Searches indicate that all of the WA Tenements encroach on land which is classified as a Class "A" Reserve, namely Use and Benefit of Aboriginal Inhabitants Reserve 17614 (**Reserve 17614**).



Class “A” Reserve affords the greatest degree of protection for reserved lands. The Class “A” classification is used solely to protect areas of high conservation or high community value.

The terms of each WA Tenement granted over Reserve 17614 specify the activities that may be undertaken by the Company and the conditions under which any operations may be conducted. These terms and conditions must be adhered to by the Company when conducting any activities on the WA Tenements and Reserve 17614.

3.3.2. Groundwater Areas

The WA Tenements encroach on both the East Murchison and Goldfields Groundwater Areas to the extent described in Schedule 1, Part 2 of this Report. A number of endorsements are attached to the Tenements regarding water resource management which must be adhered to by the Company when conducting its activities on the WA Tenements.

3.3.3. General Lease

All of the WA Tenements encroach on land that is the subject of *Lease of Reserve No.s 17614 and 29452 and part of No. 21471 (Lease)*.

The land the subject of the Lease is within Reserve 17614 and has been leased to the Ngaanyatjarra Land Council (Aboriginal Corporation) for the use and benefit of Aboriginal Inhabitants.

The conditions of grant of each of the WA Tenements require certain consents to be obtained from the Minister by Hinckley Range before entering or commencing any mining, prospecting or exploration or other activity on Reserve 17614. This includes obtaining entry permits issued under relevant legislation.

3.3.4. Overlapping Mining Tenure

Our Searches indicate that both L69/27 and E69/535 overlap each other as described in Schedule 1, Part 2 of this Report. As the Company will be acquiring both L69/27 and E69/535 the effect of their respective overlap with each other will not be significant.

4. SA TENEMENTS

4.1. Searches

We have arranged for the following searches and enquiries to be conducted in respect of the SA Tenements for the purpose of this Report:

- (a) searches of the SA Tenements in the SARIG register maintained by the South Australian Department for Energy and Mining (**DEM**) pursuant to the SA Mining Act on 4 November 2021 and key details are summarised in Schedule 2 of this Report;



SOLICITORS' REPORT ON TENEMENTS
NICO Resources Limited

- (b) searches of the SA Tenements in the SARIG database maintained by DEM in connection with any interests held in the land underlying the SA Tenements on 8 November 2021 and key details are summarised in Schedule 2 of this Report;
- (c) searches of the Register of Native Title claims maintained by the National Native Title Tribunal (**NNTT**) on 11 November 2021 in respect of the land covered by the SA Tenements and key details are summarised in Schedule 3, Part 2 of this Report; and
- (d) searches of the Register of Aboriginal Sites and Objects kept and maintained by the South Australian Department of the Premier and Cabinet for any Aboriginal sites registered over the SA Tenements on 11 November 2021 and key details are summarised in Schedule 4, Part 4 of this Report,

(SA Searches).

We have made enquiries with the Company as to all material agreements relating to the SA Tenements. Details of those provided to us by the Company for the purposes of this Report are set out in Schedule 5 of this Report.

4.2. Tenements Granted under the SA Mining Act

4.2.1. Generally

Mineral exploration and development in South Australia is regulated and administered under the SA Mining Act and associated laws and regulations.

The SA Tenements comprise of two exploration licences granted under SA Mining Act.

Outlined below is a summary of the key provisions that relate to exploration licences in South Australia. Schedule 2 of this Report describes any exclusions, encumbrances and other specific conditions which attach to the SA Tenements.

4.2.2. Exploration Licences

An exploration licence authorises the licensee to carry out exploratory operations of a kind described in the licence in respect of the land described, or referred to, in the licence. The licensee is not permitted to carry out exploratory operations for precious stones on land within a precious stones field that is outside an opal development area.

Once granted an exploration licence will continue for an initial term not exceeding 5 years, which term may be extended at the discretion of the responsible Minister provided that the aggregate term of the licence does not exceed 5 years. If the licence is renewed, the terms and conditions may be varied, revoked or added to and the licence area may be reduced.

The Minister may, on the expiration of an exploration licence's initial 5 year term, or aggregate 5 year term, grant to the licensee an exploration licence over the area of land (or part thereof) to which the former licence applied. The subsequent tenement may be



granted for a period of up to 5 years and will be subject to conditions in accordance with the SA Mining Act.

An exploration licence may be granted, subject to such conditions as the Minister determines. Exploration licences are also issued subject to a standard schedule of general exclusions and conditions under the SA Mining Act.

The area of an exploration licence must not exceed 1,000 square kilometres unless the Minister considers there are justifiable reasons to allow a larger area.

No legal or equitable interest in or affecting an exploration licence can be assigned, transferred, mortgaged, sublet, or made the subject of any trust or otherwise dealt with (either directly or indirectly) without the written consent of the Minister.

Upon acquiring the Shares, the Company will hold an interest in two exploration licences, EL 5860 and EL 6240.

4.2.3. **Tenement conditions and Forfeiture**

Mining tenements in South Australia are granted subject to various standard conditions prescribed by the SA Mining Act, including payment of annual rent, minimum expenditure requirements, reporting requirements and those relating to the environment. In addition, more particular conditions are imposed on specific tenements.

A failure to comply with these conditions or obtain an exemption from compliance may lead to cancellation of an exploration licence. Where an exploration licence is suspended or cancelled, the licence holder may, within 28 days after the cancellation or suspension, appeal to the Environmental, Resources and Development Court who may, if it is satisfied that there is no proper ground for the cancellation or suspension, declare that cancellation or suspension void.

The conditions imposed on the SA Tenements are not contained in the publicly available searches described under clause 4.1. The conditions imposed on each of the SA Tenements are set out Schedule 2, Part 1 of this Report from the tenement grant documents provided to us by the Company. We have been informed by representatives of the Company that there have been no changes to the conditions attached to each SA Tenement.

On the basis of our searches, we are not aware of any material non-compliance with the conditions or endorsements attaching to the SA Tenements.

Mining tenements in South Australia are also subject to statutory requirements of certain other Acts including:

- (a) *Aboriginal Heritage Act 1988* (SA) (**SA Heritage Act**), which is discussed in Section 6.3 of this Report; and
- (b) various South Australian legislation regarding environmental protection, conservation and water, the full details of which are beyond the scope of this Report.



4.2.4. Bonds

The SA Searches indicate that tenement EL 5860 is subject to Bond No 467 (**Bond 467**). EL 6240 does not appear to be subject to any bonds.

Bond 467 is granted pursuant to section 62 of the SA Mining Act to the Minister in respect of any civil or statutory liability likely to be incurred in the course of carrying out mining operations on EL 5860, as well as any present and future obligations in relation to the rehabilitation of the land disturbed by mining operations. Bond 467 is in the amount of \$15,000 and is granted to the Minister subject to various terms and conditions.

4.3. Land Use and Access

The SA Searches indicate that the SA Tenements overlap a number of reserves and other tenure.

The Company may be required, in respect of exploration or mining activities on the SA Tenements, to recognise the rights of, obtain the consent of, and/or pay compensation to the holders of third-party interests which overlay areas within the SA Tenements, including other mining tenure, pastoral leases, other leases, petroleum tenure or private land. This is in addition to the legislative requirements pertaining to Aboriginal heritage, Aboriginal land rights and native title.

Any delays or costs in respect of conflicting third-party rights, obtaining necessary consents, or compensation obligations, may adversely impact the Company's ability to carry out exploration or mining activities within the affected areas.

Schedule 2, Part 2 of this Report contains a summary of the types and extent of each of the various encroachments affecting the SA Tenements as identified by the SA Searches.

4.3.1. Infrastructure

The SA Searches indicate that the SA Tenements encroach on land which is currently used for various infrastructure purposes, including minor roads, road trains, power distribution, airports and airstrips.

The terms of the SA Tenements granted over such areas only permit certain activities with the prior written consent of the Minister responsible for the SA Mining Act (which may impose conditions on the undertaking of such activities) or state that such consent has been granted subject to certain conditions.

4.3.2. Land Use

Each of the SA Tenements are located within a Landscape Management region and the Aboriginal lands belonging to the APY (defined below). APY lands are an area with restricted exploration, mining and production access. This issue is further described in Section 8 of this Report.



4.3.3. Special Locations

The SA Searches indicate that both SA Tenements are within two designated Special Locations, Aboriginal Lands (being the APY lands discussed in Section 8 of this Report) and an Indigenous Protected Area (the full details of which are beyond the scope of this Report).

5. BIOSECURITY AND STATE OF EMERGENCY

5.1.1. COVID-19 and regional travel restrictions

In response to the COVID-19 pandemic, the governments of Western Australia and South Australia both declared a State of Emergency which allowed them invoke powers to impose restrictions and issue directions and determinations regarding travel to including to, from and within regional areas.

While some of these restrictions have been revoked, the restrictions are fluid and some are still in place regarding entry to certain remote Aboriginal communities to protect the health and wellbeing of residents.

Both the WA Tenements and SA Tenements are located near or within remote Aboriginal communities and have been the subject of restrictions regarding access for some time.

Any continued or additional restrictions or directions which may be issued in response to the COVID-19 pandemic may impact on the ability of the Company to access its tenure.

5.1.2. Impact on WA Tenements

The WA Government's *Remote Aboriginal Communities Directions (No. 3)* outlines the relevant rules regulating people entering remote Aboriginal communities due to the COVID-19 pandemic. This includes the community of Wingellina which is located within close proximity of the WA Tenements and in particular the exploration camp located on the WA Tenements. The directions specify the purposes allowing certain people to enter remote Aboriginal communities and anyone attempting to enter a community for any other purpose must obtain written permission.

We are informed by the Company that the Shire of Ngaanyatjaraku also places entry conditions on any person wishing to access the area of the WA Tenements. We are instructed that the Company (via its relevant subsidiary) currently holds the appropriate entry permit.

5.1.3. Impact on SA Tenements

The South Australian Department of the Premier and Cabinet states that the previous entry restrictions applying to some remote and regional Aboriginal communities have now ended. However, some local restrictions may still apply and those wishing to enter remote Aboriginal communities should contact local Aboriginal councils.



SOLICITORS' REPORT ON TENEMENTS NICO Resources Limited

We are informed by the Company that due to several factors, including the COVID-19 pandemic, permission is required to enter onto APY lands (defined below) over which the SA Tenements are situated. We are instructed that the Company (via its relevant subsidiary) currently holds the appropriate permit to enter onto APY lands and this is subject to any further requirements which may be imposed.

6. ABORIGINAL HERITAGE

6.1. Generally

There may be sites of Aboriginal heritage or significance located on the land the subject of the Tenements which are subject to both Commonwealth and state based legislation.

Each of WA, SA and the Commonwealth maintain registers regarding Aboriginal heritage, however these are not conclusive and the results noted in our Searches may not reflect all areas of Aboriginal significance located on or under the areas of the Tenements. Further, the exact location of those that are registered is not always ascertainable from such Searches.

There may still be sites, objects, remains or relics of Aboriginal cultural significance at or on these locations even though the relevant register does not identify them. All Aboriginal sites, objects, remains or relics located within the area of the Tenements are protected under the Commonwealth Heritage Act, WA Heritage Act and SA Heritage Act (as applicable) whether they are listed in the relevant register or not.

To ensure that that it does not contravene either of the Commonwealth Heritage Act, WA Heritage Act or SA Heritage Act, while carrying out operations on the Tenements, the Company would need to conduct heritage surveys to determine if any Aboriginal sites, objects, remains or relics exist within the area of the Tenements. If so, the Company would also need to ensure that any interference with such Aboriginal sites, objects, remains or relics is in strict conformity with the provisions of the above Commonwealth Heritage Act, WA Heritage Act or SA Heritage Act (as applicable).

6.2. Commonwealth Aboriginal Heritage

The *Aboriginal and Torres Strait Islander Heritage Act 1984* (Cth) (**Commonwealth Heritage Act**) applies to the Tenements and is aimed at the preservation and protection of significant Aboriginal areas and significant Aboriginal objects. This Act only applies if, and to the extent, a declaration has been made by the Commonwealth Minister for Aboriginal Affairs.

6.3. WA Aboriginal Sites and Surveys

The WA Heritage Act applies to the WA Tenements and makes it an offence to, among other things, alter or damage an Aboriginal site or object on or under an Aboriginal site. A site is defined to include any sacred, ritual or ceremonial site which is of importance and



special significance to persons of Aboriginal descent. There is no requirement or need for a site to be registered in any public manner or, indeed, be in any way acknowledged as an Aboriginal site for it to qualify as an Aboriginal site for the purposes of the WA Heritage Act.

Our Searches of AHIS indicate that there are a number of registered and non-registered places and sites of Aboriginal heritage or significance located on the WA Tenements as well as a number of heritage surveys conducted over the WA Tenements. The results of these searches are summarised in Schedule 4, Parts 1, 2 and 3 of this Report.

6.4. SA Aboriginal Sites and Surveys

Aboriginal heritage is regulated in South Australia under the SA Heritage Act. Section 23 notes that a person must not, without the Premier's authority:

- (a) damage, disturb or interfere with any Aboriginal site (whether registered or not); or
- (b) damage any Aboriginal object (whether registered or not); or
- (c) where any Aboriginal object or remains are found:
 - (i) disturb or interfere with the object or remains; or
 - (ii) remove the object or remains.

There is also a duty under section 28 on a person to take reasonable measures to protect an Aboriginal object in that person's ownership or possession as part of a public or private collection.

An Aboriginal heritage agreement may be entered into under Division 6 of the SA Heritage Act, which, once registered, will be noted on the relevant instrument. There do not appear to be any registered Aboriginal heritage agreements with respect to the SA Tenements.

Our Searches of the Register of Aboriginal Sites and Objects indicate entries for registered Aboriginal cultural heritage sites within the boundaries of the SA Tenements. The results of these searches are summarised in Schedule 4, Part 4 of this Report.

7. NATIVE TITLE

7.1. Native Title Generally

On 3 June 1992, the High Court of Australia held in *Mabo v Queensland* that the common law of Australia recognises a form of native title. In order to maintain a native title claim, the persons making such claim must show that they enjoyed certain customary rights and privileges in respect of a particular area of land and that they have maintained their traditional connection with that land. Such a claim will not be recognised if native title has been extinguished or otherwise lost, either by voluntary surrender to the Crown, death of



SOLICITORS' REPORT ON TENEMENTS
NICO Resources Limited

the last survivor of a community entitled to native title, abandonment of the land in question by that community or the granting of an "inconsistent interest" in the land by the Crown.

Native title rights and interests can be "extinguished" by the grant of inconsistent rights. The grant of freehold land is wholly inconsistent with native title rights and interests. The granting of a non-exclusive interest will not extinguish native title unless it is wholly inconsistent with native title and native title rights will co-exist with that interest to the extent that they are not inconsistent with that interest.

The Commonwealth Parliament responded to the Mabo decision by passing the *Native Title Act 1993* (Cth) (**NTA**). Among other things, the NTA:

- (a) regulates the recognition and protection of native title;
- (b) confirms the validity of titles granted by the Federal Government prior to the commencement of that Act on 1 January 1994;
- (c) specifies the procedures to be complied with for certain future acts which affect native title; and
- (d) specifies the procedures by which Aboriginal people can claim native title and by which people determined to hold native title can claim compensation.

The NTA was extensively amended in 1998 by the Native Title Amendment Act 1998. These amendments include the validation of any titles that may have been invalidly granted over pastoral leases and certain other leasehold interests during the period 1 January 1994 to 23 December 1996. Other significant amendments include a revised threshold test for the acceptance of native title claims, confirmation of extinguishment of native title by the grant of "exclusive possession" pastoral leases and certain other leasehold interests and provisions intended to deal with overlapping claims.

The Western Australian Parliament has enacted the *Titles (Validation) and Native Title (Effect of Past Acts) Act 1995* which adopts the NTA in Western Australia.

The majority of the High Court concluded in the Ward decision (8 August 2002) that, among other things:

- (a) native title is wholly extinguished in respect of land the subject of freehold, public works or other previous "exclusive possession" acts, and in respect of minerals and petroleum which are vested in the Crown, as well as various other grants and vestings; and
- (b) native title is partially extinguished as a result of the grant of "non-exclusive possession" pastoral leases and mining leases, and also as a result of the creation of certain reserves.



7.2. Native Title Claims

Persons claiming to hold native title may lodge an application for determination of native title (being a native title claim) with the Federal Court. Applications which are lodged with the Federal Court will be referred to the NNTT for the purposes of registration of the claim.

If the Native Title Registrar is satisfied that a claim meets the registration requirements set out in the NTA (**Registration Test**), it will be entered on the Register of Native Title Claims maintained by the NNTT (**NT Register**). Claimants of registered claims are afforded certain procedural rights under the NTA including the "right to negotiate" discussed further below.

Claims which fail to meet the Registration Test are recorded on the Schedule of Applications Received maintained by the NNTT. Such claims may be entered on the NT Register at a later date if additional information is provided by the claimant that satisfies the Registration Test. Claims which are not registered do not get the right to negotiate. Claims that are deregistered lose the right to negotiate from the date of deregistration but will still remain on foot in the Federal Court until such time as they are determined by the Court.

The fact that a claim has been lodged (but not yet determined) does not necessarily mean that native title exists over the area claimed, nor does the absence of a claim necessarily indicate that no native title exists over that area. The existence of native title will be established in due course as the undetermined claims are determined by the Federal Court.

We have not undertaken, nor are we qualified to undertake, the considerable historical, anthropological and ethnographic work that would be required to determine the possibility of any further claims in respect of the area of the WA Tenements being made in the future. In some cases, more than one claim applies to the WA Tenements.

7.3. Validity of Title – Granted Tenements

The grant of a mining tenement is an act that is capable of affecting, and which may affect, native title. The future act processes of the NTA provide a mechanism for achieving the valid grant of a mining tenement in terms of native title. The validity of a mining tenement granted in Western Australia is dependent on its date of grant.

7.3.1. Tenements granted prior to 1 January 1994

Under the *Titles (Validation) and Native Title (Effect of Past Acts) Act 1995* (WA), the grant of mining tenements granted in Western Australia prior to 1 January 1994 has been validated to the extent that the grant may have been invalid as a result of the existence of native title.

One of the WA Tenements was granted during this period.



7.3.2. Tenements granted between 1 January 1994 and 23 December 1996

The Western Australian Parliament passed the *Titles Validation Amendment Act 1999* (WA) which confirmed the validity of certain acts made by the State of Western Australia between 1 January 1994 and 23 December 1996, provided such acts had met various conditions set out in the NTA, primarily that there was some form of underlying non-exclusivity at the time of grant.

None of the WA Tenements were granted during this period.

7.3.3. Tenements granted after 23 December 1996

Mining tenements granted since 23 December 1996 which are affected by native title rights and interests will be valid provided the applicable processes prescribed by the NTA were complied with. We understand that it has been the practice of the Western Australian Government to comply with these processes but we have not undertaken any independent enquiries to confirm that this is the case.

One of the WA Tenements was granted during this period and is therefore subject to the NTA.

7.4. ILUA

An ILUA is an agreement which has been authorised by the native title claimant group and has been registered with the NNTT. In such cases, the procedures prescribed by the ILUA must be followed to obtain the valid grant of the tenement and these procedures will vary depending on the terms of the relevant ILUA.

An ILUA binds the parties to the ILUA and also all persons holding native title to the relevant area that may not be a party. If an ILUA provides that any particular mining tenement(s) may be granted, then the relevant mining tenement(s) may be granted as provided for by the ILUA, generally without following other procedures, including the “right to negotiate” process or the “expedited procedure”.

7.5. Future Tenement Grants

As stated above, the valid grant of any of the WA Tenements which may affect native title requires full compliance with the “future act” provisions of the NTA, in addition to compliance with the usual procedures under the State's mining legislation. The primary future act procedure prescribed under the NTA applicable to mining tenements is the “right to negotiate” process.

The right to negotiate process involves the publishing of a notice of the proposed grant of a tenement followed by negotiation in good faith between the relevant State Government, the tenement applicant and the relevant registered native title claimant or holder. If agreement to enable the grant to occur is not reached within six months of the relevant notification, the matter may be referred to arbitration before the NNTT, which has a



further six months to make a determination. A party to a determination of the NNTT may appeal that determination to the Federal Court on a question of law.

The NTA provides that, in relation to the grant of mining tenements in certain areas, a State law can operate in lieu of the right to negotiate process of the NTA. These areas are principally areas covered by pastoral leases. The Western Australian State Government has not yet introduced such a law.

As noted above, the right to negotiate process does not have to be pursued in cases where an ILUA is negotiated with the relevant Aboriginal people and registered with the NNTT. Similarly, if any other type of agreement is reached between a mining company or other proponent and a native title group which allows the grant of future tenements, the right to negotiate process may not have to be followed with that native title group but the parties will be required to enter into a State Deed pursuant to section 31 of the NTA which refers to the existence of that other ancillary agreement and confirms that the tenement can be granted. A State Deed is a standard form document prepared by the State Government and available from DMIRS.

The right to negotiate process also doesn't apply for grants of tenure for the sole purpose of infrastructure (as defined under the NTA). Depending on the purpose for which they are sought, this applies to most miscellaneous licences and general purpose leases. For that tenure, an alternate consultative process applies. If, after consultation, the native title claimants or holders object to the grant, the matter can be referred to an "independent person" (as defined under the NTA) for assessment. Regardless of the independent person's assessment the State Minister still has the power to undertake the act.

7.6. Renewal of Titles

As with the grant of mining tenements, renewals of mining tenements granted prior to 1 January 1994, to the extent the renewals were invalid due to native title, have been validated by legislation. Renewals granted between 1 January 1994 and 23 December 1996 have been similarly validated provided certain statutory criteria have been met.

Renewals made after 23 December 1996 of tenements validly granted before that date, whether they be first renewals or subsequent renewals, will not be subject to the right to negotiate process provided:

- (a) the area to which the earlier right is made is not extended;
- (b) the term of the new right is not longer than the term of the earlier right; and
- (c) the rights to be created are not greater than the rights conferred by the earlier grant.

Other than as stated above, renewals of mining tenements are subject to the same right to negotiate (or, pending legislation, alternative State) process as is described above.



7.7. Native Title Claims, Determinations and ILUAs affecting the WA Tenements

The NNTT Searches we obtained in respect of the WA Tenements indicate that they lie within registered native title determination areas and ILUA areas. The common law holders of native title in respect of the land over which the WA Tenements have been granted are the Peoples of the Ngaanyatjarra Lands. Details of the determination and ILUA have been summarised in Schedule 3, Part 1 of this Report.

The existence of any native title claims over the area covered by the WA Tenements, or a subsequent determination of native title over the area, will not impact the rights and interests of the holder under the WA Tenements provided they have been validly granted. However, the grant of any future tenure over areas that are covered by a registered claim, positive determination of native title or ILUA will require engagement with the relevant claimants or native title holders (as relevant) in accordance with the NTA.

Our Searches indicate that an ILUA, as well as other agreements, have been entered into by representatives of the Peoples of the Ngaanyatjarra Lands and Hinckley Range in relation to the WA Tenements. A summary of this ILUA and the other agreements are contained in Schedule 5 of this Report.

7.8. Native Title Claims, Determinations and ILUAs affecting the SA Tenements

Our Searches indicate that no native title claims or determinations currently exist over the SA Tenements. However, this does not mean that no claims or determinations may exist in the future.

While there are no native title claims or determinations, the SA Tenements are subject to indigenous land rights and these rights are detailed in section 8 of this Report.

8. SA INDIGENOUS LAND RIGHTS

8.1. APY Land Rights

While no native title claims or determinations currently exist over the SA Tenements (as noted above), the SA Tenements are situated on lands belonging to the Anangu Pitjantjatjara Yankunytjatjara, the body corporate constituted under this name by the *Anangu Pitjantjatjara Yankunytjatjara Land Rights Act 1981* (SA) (APY).

APY is the registered holder in fee simple of a large area of land situated in far northwest South Australia and is responsible for the management, use and control of the Anangu Pitjantjatjara Yankunytjatjara Lands. It provides approval for the management, use and control of the lands in consultation with traditional owners.



8.2. Rights affecting the SA Tenements

Works on the APY lands can only be commenced with the consent of APY and the consent of APY may be given subject to such conditions as APY thinks fit, including the completion of heritage impact assessments by APY and entering into agreements governing activities.

In the case of the SA Tenements, access to the APY lands and the conduct of exploration, mining and associated activities on the APY lands is subject to the terms and conditions set out in two deeds of exploration (**Exploration Deeds**).

The requirement to comply with the terms of these Exploration Deeds is also set out in the conditions of grant for each SA Tenement:

- (a) the "February 2006 APY Agreement" which relates to EL 6240; and
- (b) the "May 2006 APY Agreement" which relates to EL 5860.

The Exploration Deeds set out the terms and process for access and conduct of exploration activities on the SA Tenements as well as annual and other payments to be made to APY. Mining is not permitted under the Exploration Deeds, however they do set out a process regarding the preparation of mining proposals and mining agreements.

A summary of the material terms and conditions of the Exploration Deeds is contained in Schedule 5 of this Report.

9. ASSUMPTIONS AND QUALIFICATIONS

The statements and comments in this Report are based solely on information derived from the WA Searches and SA Searches described in Sections 3.1 and 4.1 of this Report (**Searches**).

We are not in a position to confirm the reliability, accuracy or completeness of the information provided to us. Any comments made or opinions expressed assume that the information provided to us is reliable, accurate and complete.

Our report is subject to the following qualifications and assumptions:

- (a) While the status of the Tenements is dealt with in detail in Schedule 1 and Schedule 2, we point out by way of summary, that:
 - (i) we have assumed the results of the Searches which we have made or caused to be made are accurate, complete and up-to-date;
 - (ii) we have relied on the accuracy of the Registers and databases maintained by the governmental bodies referred to in Sections 3.1 and 4.1 of this Report;



SOLICITORS' REPORT ON TENEMENTS
NICO Resources Limited

- (iii) we have not obtained any further searches other than those referred to in Sections 3.1 and 4.1 of this Report; and
 - (iv) the holding of the Tenements is subject to compliance with their terms and conditions and the provisions of the Mining Act and the information available from the searches we conducted only includes information in relation to compliance with some such terms, conditions and provisions
 - (v) we have not undertaken an investigation as whether the Company complied with all the strict requirements in respect of, and when it submitted its applications for, the Tenements.
- (b) Further, we have only considered native title rights to the extent that they were recorded in the results of the Searches described in Sections 3.1 and 4.1 of this Report. As it is beyond the scope of this Report, we have not undertaken searches of:
- (i) the register of contaminated sites maintained by the Department of Water and Environmental Regulation; and
 - (ii) searches of deregistered and unregistered native claims with NNTT.
- (c) We have not expressed, and should not be taken as having expressed, any opinions as to the validity, binding effect, legality or enforceability of any documents or agreements. At the date of this Report, we have assumed that each document or agreement is properly executed and that each is valid, binding, lawful and enforceable under any applicable laws.
- (d) We have not undertaken the extensive research necessary to establish if native title claims may be made in the future over the area of the Tenements. We have not researched the area of the Tenements or undertaken searches to determine whether any native title and Aboriginal heritage sites or objects may exist in the areas covered by the Tenements that are currently not registered.
- (e) Other than as set out in this Report, we have not conducted searches of any publicly available information related to the Tenements or any of the parties described in this Report.
- (f) We have assumed the results of our Searches are accurate as at the date of our Searches. We have also relied on the information in the registers being maintained by the relevant agencies and bodies (upon which the Searches are based) being accurate, complete and up to date.
- (g) The records of the relevant agencies and bodies may not be complete or up to date and may not record details of all interests and encumbrances, lodged for registration or which may otherwise be enforced against the Tenements.

**SOLICITORS' REPORT ON TENEMENTS**
NICO Resources Limited

- (h) That we have made an assumption in this Report does not imply that we have made any enquiry to verify any assumption or are not aware of any circumstance which would affect the correctness of any assumption.
- (i) Other contractual rights in relation to the Tenements may exist that will not be reflected on the relevant mining registers. This is because it is not possible to register any contractual right, transfer or dealing in relation to an application for a mining tenement.
- (j) We cannot comment on whether any changes have occurred in respect of the Tenements between the date on which the Searches were conducted and the date of this Report.
- (k) We have assumed that the information supplied to us (including the responses to the requests for documents) is complete and accurate and is not misleading or deceptive by omission or otherwise.
- (l) The scope of this Report has necessarily precluded us from making more extensive investigations. Our investigations may not have revealed all matters that a more extensive investigation might disclose.

10. CONSENT

This Report is given solely for the benefit of the Company in connection with the Prospectus. It is not to be relied on or used for any other purpose or quoted or referred to in any public document or filed with any government body or other person without our prior consent.

Yours faithfully

BLACKWALL LEGAL LLP
Will Moncrieff, Counsel



SCHEDULES TO SOLICITORS' REPORT ON TENEMENTS
NICO Resources Limited

Schedule 1 – WA Tenements

Part 1: WA Tenement Details

Tenement	Registered Holder	% Held	Grant Date	Expiry Date	Expenditure Commitment (current year)	Annual Rent (current year)	Notes, Conditions, Endorsements and Encumbrances
E69/535	Hinckley Range	100%	23 December 1993	22 December 2021	\$108,000.00	\$24,372.00	Conditions: 1-6 Endorsements: 1, 2, 5, 7-10 Encroachments: See Schedule 1, Part 2 Caveat 662H/045 lodged on 25 May 2005 by Metex Nickel Application for renewal lodged 29 July 2021
E69/3065	Hinckley Range	100%	5 June 2013	4 June 2023	\$70,000.00	\$8,124.00	Conditions: 1-4, 7, 8 Endorsements: 2, 4,5, 10, 12, 13 Encroachments: See Schedule 1, Part 2
L69/12	Hinckley Range	100%	26 February 2009	25 February 2030	N/A	\$8,695.80	Conditions: 8-15 Endorsements: 2-4, 14, 15 Encroachments: See Schedule 1, Part 2 Purpose: search for groundwater
L69/19	Hinckley Range	100%	29 August 2013	28 August 2034	N/A	\$12,235.80	Conditions: 1-3, 8, 9, 16, 17 Endorsements: 2, 4-6, 10, 12-14 Encroachments: See Schedule 1, Part 2 Purpose: search for groundwater
L69/27	Hinckley Range	100%	13 June 2018	12 June 2039	N/A	\$3,717.00	Conditions: 2, 3, 8 Endorsements: 2, 4, 5, 7, 8, 10, 11, 14 Encroachments: See Schedule 1, Part 2 Purpose: search for groundwater



**SCHEDULES TO SOLICITORS' REPORT ON TENEMENTS
NICO Resources Limited**

Key:

- E Exploration Licence
L Miscellaneous Licence

Notes

The following notes are summaries of the conditions and endorsements of each WA Tenement as described on the WA Mining Register maintained by DMIRS. These notes are substantially the same as, but may differ in some respects, to the precise wording of the conditions on the WA Mining Register and the numbers that reference them in this document will be different to those used in the WA Mining Register.

Conditions

1. All surface holes drilled for the purpose of exploration are to be capped, filled and otherwise made safe after completion.
2. All disturbances to the surface of the land made as a result of exploration, including costeans, drill pads, grid lines and access tracks, being backfilled and rehabilitated to the satisfaction of the Environmental Officer, DMIRS. Backfilling and rehabilitation being required no later than 6 months after excavation unless otherwise approved in writing by the Environmental Officer, DMIRS.
3. All waste materials, rubbish, plastic sample bags, abandoned equipment and temporary buildings being removed from the mining tenement prior to or at the termination of exploration program.
4. Unless the written approval of the Environmental Officer, DMIRS is first obtained, the use of drilling rigs, scrapers, graders, bulldozers, backhoes or other mechanised equipment for surface disturbance or the excavation of costeans is prohibited. Following approval, all topsoil being removed ahead of mining operations and separately stockpiled for replacement after backfilling and/or completion of operations.
5. No mining on Use and Benefit of Aboriginal Inhabitants Reserve "A" 17614 without the prior written consent of the Minister for Mines.
6. Consent to Mine on Use and Benefit of Aboriginal Inhabitants Reserve 17614 given subject to Entry Permit Number M01/29 issued by Minister for Indigenous Affairs and valid from 3 September 2001.
7. The prior written consent of the Minister responsible for the Mining Act 1978 being obtained before entering or commencing any prospecting or exploration activity on Use and Benefit of Aboriginal Inhabitants Reserve 17614.
8. Consent to explore or commence activities (as applicable) on Use and Benefit of Aboriginal Inhabitants Reserve 17614 granted subject to the following conditions:
 - (a) Entry on Use and Benefit of Aborigines Reserve 17614 and activities and take undertaken on the License by any non-Aboriginal lessee, licensee, employee, contractor, or agent being authorised by an entry permit issued under the provisions of the *Aboriginal Affairs Planning Authority Act 1972*.
9. On the completion of the life of mining operations in relation to this license the holder shall:
 - remove all installations constructed pursuant to this licence;
 - cover over all wells and holes in the ground to such a degree of safety as shell can be determined by the Environmental Officer, DMIRS; and
 - on such areas cleared of natural growth by the holder or any of its agents, the holder shall plant trees and/or shrubs and/or other plant as shall conform to the general pattern and type of growth in the area and as directed by the Environmental Officer, DMIRS and properly maintain same until the Environmental Officer advises regrowth is self supporting,
 unless the Mining Registrar or Minister responsible for the Mining Act (as required) orders or consents otherwise.
10. Written notification, where practicable, of the time frame, type and extent of proposed ground disturbing activities being forwarded to the Department of Water Kalgoorlie seven days prior to commencement of those activities.
11. Exploration activities, ground-breaking activities, or mining operations that:
 - (a) disrupt the natural flow of any watercourse or hydrology of a wetland;
 - (b) disturb or remove any significant waterway (flowing or not), wetland or its fringing vegetation that may exist on site; or
 - (c) take place within 50m from a perennial waterway and 30m from the seasonal waterway,
 are prohibited without prior written approval from the Department of Water.



**SCHEDULES TO SOLICITORS' REPORT ON TENEMENTS
NICO Resources Limited**

12. The rights of ingress to and egress from the License being at all reasonable times preserved to officers of the Department of Water for inspection and investigation purposes.
13. The storage and disposal of hydrocarbons, chemicals and potentially hazardous substances being in accordance with the Department of Water's Guidelines and Water Quality Protection Notes
14. Activities requiring the abstraction of groundwater are prohibited unless a bore construction and abstraction license has been granted by the Department of Water.
15. The construction and operation of the project and measures to protect the environment to be carried out in accordance with the document titled:
- (Reg. ID33079) "Program of Work on L69/12 for Metals X Limited" dated 10 November 2011 signed by Richard Coles and retained on DMIRS file No. EARS-POW-33079
Where a difference exists between the above document and the following conditions, then the following conditions shall prevail.
 - (a) The development and operation of the project been carried out in such a manner as to create the minimum practicable disturbance to the existing vegetation and natural landform.
 - (b) All topsoil being removed ahead of mining operations from sites such as pit areas, waste disposal areas, ore stockpile areas, pipeline, haul roads and new access roads and being stockpiled for later respreading or immediately respread as rehabilitation progresses.
16. The Licensee submitting a plan of proposed operations and measures to safeguard the environment to the Executive Officer, Environment Division, DMIRS for assessment and written approval prior to commencing any development or construction.
17. Where surface disturbance activities are proposed on the licence which are not associated with development or construction proposals, the prior written approval of the Environmental Officer, DMIRS, must be obtained before the use of drilling rigs, scrapers, graders, bulldozers, backhoes or other mechanised equipment for proposed surface disturbance activities. Following approval, all topsoil being removed ahead of mining operations and separately stockpiled for replacement after backfilling and/or completion of operations.

Endorsements

1. Pursuant to the *Savings and Transitional Provisions of the Mining Amendment Act 1990* all and surrendered, forfeited (other than forfeiture by plaintiff action) or expiring from a non-gratular exploration licence will automatically be included into a gratular exploration licence, provided the surrender, forfeiture or expiry occurred after the grant of the gratular licence.
2. The Licensee's/Lessee's attention is drawn to the provisions of the *Aboriginal Heritage Act 1972* and any Regulations thereunder.
3. The Licensee's attention is drawn to the provisions of the:
 - (a) *Water and Rivers Commission Act 1995* and any Regulations thereunder
 - (b) *Rights in Water and Irrigation Act 1914* and any Regulations thereunder
 - (c) Draft Environmental Protection Groundwater Policy 1998
4. The Licensee's/Lessee's attention is drawn to the *Environmental Protection Act 1986* and *Environmental Protection (Clearing of Native Vegetation) Regulations 2004* which provides for the protection of all native vegetation from damage unless prior permission is obtained.
5. In respect to Water Resource Management Areas (WRMA) the following endorsements apply:
 - (a) The Lessee's attention is drawn to the provisions of the:
 - (i) *Waterways Conservation Act 1976*
 - (ii) *Rights in Water and Irrigation Act 1914*
 - (iii) *Metropolitan Water Supply, Sewage and Drainage Act 1909*
 - (iv) *Country Areas Water Supply Act 1947*
 - (v) *Water Agencies (Powers) Act 1984*
 - (b) The rights of ingress and egress from, and to cross over and through, the mining tenement being at all reasonable times preserved to officers of Department of Water and Environmental Regulation (previously known as Department of Water or DoW (**DWER**) for inspection and investigation purposes.
 - (c) The storage and disposal of petroleum hydrocarbons, chemicals and potentially hazardous substances being in accordance with the current published version of the DWER relevant Water Quality Protection Notes and Guidelines for mining and mineral processing.
6. In respect to Water Resource Management Areas (WRMA) the following endorsements apply:
 - (a) The Lessee's attention is drawn to the provisions of the:
 - (i) *Water Resources Legislation Amendment Act 2007*



**SCHEDULES TO SOLICITORS' REPORT ON TENEMENTS
NICO Resources Limited**

7. Measures such as draining controls and stormwater retention facilities are to be implemented to minimise erosion and sedimentation of adjacent areas, receiving catchments and waterways.
8. All activities to be undertaken so as to avoid or minimise damage, disturbance or contamination of waterways, including their beds and banks, and riparian and other water dependent vegetation.
9. The taking of groundwater and the construction or altering of any well is prohibited without current licences for these activities issued by DWER, unless an exemption otherwise applies.
10. The taking of groundwater from an artesian well and the construction, enlargement, deepening or altering of any artesian well is prohibited unless current licenses for these activities have been issued by DWER.
11. The taking of groundwater and the construction or altering of any well is prohibited without current licenses for these activities issued by DWER, unless an exemption otherwise applies.
12. In respect of Waterways the following endorsement applies:
 - (a) Advice shall be sought from DWER if proposing any exploration within a defined waterway and within a lateral distance of:
 - 50m from the outer-most water dependent vegetation of any perennial waterway; and
 - 30m from the outer-most water dependent vegetation of any seasonal waterway
13. In respect to Proclaimed Groundwater Areas the following endorsement applies:
 - (a) The abstraction of groundwater is prohibited unless a current license to construct/alter a well and a licence to take groundwater has been issued by DWER.
14. Any expansion beyond activities associated with the search for groundwater is to be subject to an appropriate form of miscellaneous licence.
15. Persons claiming native titles to the land the subject of this mining tenements entered into a deed under the NTA with the State of Western Australia, the Minister responsible for the Mining Act and the tenement holder agreeing to the grant of the tenements. Copies of the deed were given to the NNIT pursuant to section 34 of the NTA and filed at DMIRS.

Part 2: WA Tenement Encroachments

Encroaching Land ID	Purpose / Name	WA Tenements Affected	Encroachment Area	Encroachment Percentage
HSA 23016 1	Aboriginal Heritage Survey Areas	E69/535 L69/27	11078.25Ha 3.47Ha	100% 0.06%
HSA 22302 1	Aboriginal Heritage Survey Areas	E69/535 L69/27	11078.25Ha 3.47Ha	100% 0.06%
HSA 22092 1	Aboriginal Heritage Survey Areas	E69/535 L69/27	11074.02Ha 23.19Ha	99.96% 0.37%
HSA 103368 1	Aboriginal Heritage Survey Areas	E69/535	924.79Ha	8.35%
HSA 103368 2	Aboriginal Heritage Survey Areas	E69/535	924.79Ha	8.35%
GWA 21	Groundwater Area Goldfields	L69/12	2001.04Ha	13.81%

personal use only



SCHEDULES TO SOLICITORS' REPORT ON TENEMENTS
NICO Resources Limited

Encroaching Land ID	Purpose / Name	WA Tenements Affected	Encroachment Area	Encroachment Percentage
GWA 15	Groundwater Area East Murchison	E69/535	11078.25Ha	100%
		E69/3065	3700.53Ha	100%
		L69/12	12491.46Ha	86.19%
		L69/19	20392.72Ha	100%
		L69/27	6194.99Ha	100%
GE I798552	General Lease (P)	E69/535	11078.25Ha	100%
		E69/3065	3700.53Ha	100%
		L69/12	14492.50Ha	100%
		L69/19	20392.72Ha	100%
		L69/27	6194.99Ha	100%
R 17614	"A" Class Reserve – Use and Benefit of Aboriginal Inhabitants	E69/535	11078.25Ha	100%
		E69/3065	3700.53Ha	100%
		L69/12	14492.50Ha	100%
		L69/19	20392.72Ha	100%
		L69/27	6194.99Ha	100%
L69/27	Exploration Licence held by Hinckley Range Pty Ltd	E69/535	3.47Ha	0.03%
E69/535	Miscellaneous Licence held by Hinckley Range Pty Ltd	L69/27	3.47Ha	0.06%



SCHEDULES TO SOLICITORS' REPORT ON TENEMENTS
NICO Resources Limited

Schedule 2 – SA Tenements

Part 1: SA Tenement Details

Tenement	Registered Holder	% Held	Grant Date	Expiry Date	Expenditure Commitment	Annual Fees	Notes, Conditions, Endorsements and Encumbrances
EL 5860	Austral Nickel	100%	20 June 2016	19 June 2021	\$170,000.00 for year ended 19 June 2021	\$7,665.20 for year ended 19 June 2021 No invoice issued for year ending 19 June 2022	Conditions: 1-18, 20-27, Encroachments: See Schedule 2, Part 2 Bond 467 Renewal application lodged 27 April 2021 – decision pending
EL 6240	Austral Nickel	100%	24 September 2017	23 September 2022	\$475,000.00 for year ending 23 September 2022	\$4,774.80 for year ending 23 September 2022	Conditions: 1-17, 19-26, 28-30 Encroachments: See Schedule 2, Part 2

Key:

EL Exploration Licence

Notes

The following notes are summaries of the conditions of each SA Tenement as described on the SA Mining Register maintained by DEM. These notes are substantially the same as, but may differ in some respects, to the precise wording of the conditions on the SA Mining Register and the numbers that reference them in this document will be different to those used in the SA Mining Register.

Conditions

- The Licensee is authorised to explore for all minerals except extractive minerals or precious stones within the area of the Licence excluding that part of such area being land comprised in a precious stones field, subject to a mining tenement or comprised in a private mine.
- The Licence is, if the Licensee has complied with the SA Mining Act and the Regulations and the conditions of the License during the term for which the license was granted or last renewed, entitled to the renewal of the License for a further term as determined by the Minister (but not so the aggregate term of the license exceeds 5 years) upon making application for renewal to the Minister in accordance with section 30A of the SA Mining Act.

Prescribed Conditions

- The Minister may, at any time, require the holders to pay to any person an amount of compensation, stipulated by the Minister, to which that person is, in the opinion of the Minister, entitled in consequence of loss or damage suffered by him as a result of operations conducted in pursuance of the Licence.
- The Licensee must, as soon as reasonably practicable, report to the Director the discovery on the land of minerals potentially capable of economic production.
- The Licensee must give written notice of the following matters to the Director
 - a proposal to carry out an airborne survey of the land (including details of the type of survey, the area to be surveyed, flight line spacing and flight height); or
 - a proposal to investigate the use of groundwater on the land for the purpose of water supplies, de-watering, in-situ leaching, waste disposal or other purpose.



SCHEDULES TO SOLICITORS' REPORT ON TENEMENTS NICO Resources Limited

6. The Licensee must within 60 days after making a request to the Minister for a reduction in the area of the land in respect of which the Licence operates submit to the Minister a technical report of the exploratory operations carried out in the area sought to be excluded from the Licence.

Standard Conditions

7. This Licence confers no right on the Licensee to carry out operations on "native title land" (as defined in the *Native Title (South Australia) Act 1994*) within the area of the exploration licence other than in accordance with Part 9B of the Act.
8. The Licensee shall conduct operations so as not to disturb the environment except in so far as it is necessary to undertake the relevant programme of exploration required by the Licence.
9. Unless otherwise specified under conditions of the Licence, all low impact exploration activities must be undertaken in accordance with Ministerial Determination 001; *Generic Program for Environmental Protection and Rehabilitation – Low Impact Mineral Exploration in South Australia* (Generic Low Impact Exploration PEPR).
10. Prior to conducting any on-ground exploration activity outside the scope of the Generic Low Impact Exploration PEPR, an application in accordance with Part 10A of the SA Mining Act and Ministerial Determination 013 shall be submitted to, and approved in writing by, the Minister (or delegate).
11. Prior to commencing construction of major campsites, intensive track networks, airstrips and other major support facilities, an application in accordance with Part 10A of the SA Mining Act and Ministerial Determination 013 shall be submitted to, and approved in writing by, the Minister (or delegate).
12. Failure to comply with an approved PEPR will constitute a failure to comply with the conditions of the Licence.
13. The Licensee must comply with the laws in force in South Australia in the course of undertaking any activities pursuant to this Licence, including but not limited to the SA Heritage Act, *Environmental Protection Act 1993* and *Work Health and Safety Act 2012*.
14. The Minister (or delegate) may request the Licensee to review and resubmit a revised PEPR for further approval at any time during the term of the Licence (Part 10A of the SA Mining Act).
15. In the event the Licensee encounters significant underground water during drilling operations, the Licensee shall notify the exact location of such underground water to the Director of Mines and shall, if practicable, collect samples and forward to the Director of Mines.
16. The Licensee must conduct exploratory operations in a manner that will prevent contamination or wastage of groundwater at all exploration drillhole sites and is required to complete all exploration drillholes in accordance with Information Sheet M21 - Mineral Exploration Drillholes - General specification for construction and backfilling, approved by the Director of Mines, or as amended from time to time.
17. At least 14 days prior to commencing drilling operations that are likely to intersect significant groundwater the Licensee must advise the Drilling Inspector. In the event of artesian conditions being encountered during drilling, the Drilling Inspector must be contacted within 24 hours. Drilling Inspector contact details can be found within the Department for Environment and Water advice accompanying this Licence.
18. The Licensee must provide a Six-Monthly Summary Report to the Director of Mines within 30 days after the expiry of each 6 calendar month period from the date the Licence is granted. The Report must contain information as required by the *Mineral Exploration Reporting Guidelines – A guide to the preparation and submission of technical reports for exploration in South Australia* approved by the Director of Mines, or is amended from time to time.
19. The Licensee must provide an Annual Expenditure Report to the Director of Mines within 60 days after the expiry of each 12 calendar month period from the date the Licence is granted. The Report must contain information as required by the *Mineral Exploration Reporting Guidelines – A guide to the preparation and submission of technical reports for exploration in South Australia* approved by the Director of Mines, or is amended from time to time.
20. The Licensee must provide an Annual Technical Report to the Director of Mines within 60 days after the expiry of each 12 calendar months from the date the Licence is granted, and a Final Annual Technical Report within 60 days after the expiry or surrender of the Licence. The Reports must contain information as required by the *Mineral Exploration Reporting Guidelines – A guide to the preparation and submission of technical reports for exploration in South Australia* approved by the Director of Mines, or is amended from time to time.
21. In accordance with Regulation 47 and prescribed conditions of the Licence, in the event the Licensee requests the Minister to consider reducing the area of the Licence, the Licensees must submit a Partial Surrender Report within 60 days of making its application to the Minister. The Report must contain information about the exploration undertaken in the proposed exclusion area and other information as



**SCHEDULES TO SOLICITORS' REPORT ON TENEMENTS
NICO Resources Limited**

required by the *Mineral Exploration Reporting Guidelines – A guide to the preparation and submission of technical reports for exploration in South Australia* approved by the Director of Mines, or is amended from time to time.

22. Representative drillhole samples are offered to the Geological Survey of South Australia on completion of the program or expiry of the tenement as per the Department's Information Sheet MG18, *Submission of Representative Samples for Mineral Exploration Drillholes*.
23. Exploration reports, data and samples required to be submitted under the SA Mining Act by the Licensee must be in a manner and form acceptable to the Director of Mines.
24. The Minister will endeavour to keep exploration reports, data and samples submitted in accordance with the Licence confidential while the Licence is in force except where:
 - (a) the Licensee has agreed that reports may be released;
 - (b) the reports deal with exploration conducted on areas that have ceased to be part of the licence under the SA Mining Act;
 - (c) the releases will take place in accordance with section 77D of the Act (for example data/samples that have been held for at least 5 years); or
 - (d) documents must be released pursuant to the provisions of the Freedom of Information Act 1991.
25. At the planning stage of any aerial survey, the Licensee shall provide details to the Director of Mines of the type of airborne survey, area to be surveyed, flight-line spacing, flight height and method by which landowners have been notified of low level surveys. The "Notification of an airborne survey on a Mineral Exploration Licence" form must be used for this notification.

Additional Conditions

26. Unless the Minister otherwise determines, if the Expenditure commitment of the License is not satisfied, the area of land to which the current licence applies shall be reduced by at least 25% by the end of the current term. The boundaries of the reduced area must coincide with whole minutes of latitude and longitude.
27. The Licensee shall abide by the Deed of Exploration negotiated with the Anangu Pitjantjatjara Yankunytjatjara Land Council dated 1 February 2006.
28. Prior to commencing any exploration activity involving the intensive use of vehicles, the use of declared equipment/drilling equipment within 100m of known locations of Black-footed Rock-wallaby (*Petrogale Lateralis MacDonnell Ranges race*), a PEPR in accordance with Part 10A the SA Mining Act and Ministerial Determination 013 shall be submitted to and approved in writing by the Minister (or delegate).
29. The Licensee shall abide by the Deed of Exploration negotiated with the Anangu Pitjantjatjara Yankunytjatjara Land Council dated 18 May 2006.
30. No alcohol or firearms are to be brought onto the Anangu Pitjantjatjara Yankunytjatjara Lands.



SCHEDULES TO SOLICITORS' REPORT ON TENEMENTS
NICO Resources Limited

Part 2: SA Tenement Encroachments

Purpose / Name	SA Tenements Affected
Infrastructure: Road Traffic Volumes	EL 5860 EL 6240
Infrastructure: Road Approved for HML	EL 5860 EL 6240
Infrastructure: Gazetted B-Double Routes	EL 5860 EL 6240
Infrastructure: Gazetted Road Train Routes	EL 5860 EL 6240
Infrastructure: Airports and Airstrips	EL 5860 EL 6240
Infrastructure: Power Distribution Network (SAPN)	EL 6240
Infrastructure: Minor Roads	EL 5860 EL 6240
Land Use – administration boundaries: Landscape Management Region	EL 5860 EL 6240
Land Use – restricted exploration and production access: Aboriginal Lands	EL 5860 EL 6240



Schedule 3 - Native Title and Aboriginal Land Rights

Part 1: WA Tenements

Native Title Details Claims, Determinations and ILUAs

NNTT No.	Federal Court No.	Native Title Party	NT Status	ILUA Details	Affected WA Tenement	Overlap %
WCD 2005/002	WAD 6004/2004	Ngaanyatjarra Lands (Part A)	Determined Within ILUA Area	ILUA ID: WI2011/007 (Parties as set out in Schedule 5 under "Wingellina ILUA")	E69/535 E69/3065 L69/12 L69/19 L69/27	100% 100% 100% 100% 100%

Part 2: SA Tenements

Aboriginal Land Rights

Legislation	Registered Holder of APY Lands	Affected SA Tenement	Overlap %
<i>Anangu Pitjantjatjara Yankunytjatjara Land Rights Act 1981 (SA) (APY Act)</i>	Anangu Pitjantjatjara Yankunytjatjara, the body corporate constituted under this name by the APY Act	EL 5860 EL 6240	100% 100%

Native Title Details Claims, Determinations and ILUAs

Our searches indicate that no Native Title claims or determinations are registered in respect of the SA Tenements.



SCHEDULES TO SOLICITORS' REPORT ON TENEMENTS
NICO Resources Limited

Schedule 4 – Aboriginal Heritage

Part 1: Western Australia – Aboriginal Heritage Sites

Our searches of AHIS indicate that Aboriginal Sites have only been registered over the following WA Tenements.

Tenement	Site ID	Site Name	Restrictions	Status	Site Type	Knowledge Holders
E69/535	2828	Mumpulpeni	File and Boundary Restricted No Gender Restrictions	Registered Site	Mythological, Water Source	Registered Knowledge Holder names available from DAA
	2872	Tjakura Kalpurrngarantja	File and Boundary Restricted No Gender Restrictions	Registered Site	Mythological	Registered Knowledge Holder names available from DAA
	2873	Urumpu	File and Boundary Restricted No Gender Restrictions	Registered Site	Mythological	Registered Knowledge Holder names available from DAA
	2901	Ngangku (Ngangkunya)	File and Boundary Restricted No Gender Restrictions	Registered Site	Man-Made Structure, Mythological, Rockshelter	Registered Knowledge Holder names available from DAA
	2902	Nyukarli Standing	File and Boundary Restricted No Gender Restrictions	Registered Site	Mythological	Registered Knowledge Holder names available from DAA
	2903	Jilijildjara	File and Boundary Restricted No Gender Restrictions	Registered Site	Mythological	Registered Knowledge Holder names available from DAA
	2906	Irruntju	File and Boundary Restricted No Gender Restrictions	Registered Site	Artefacts / Scatter, Ceremonial, Engraving, Man-Made Structure, Mythological, Water Source	Registered Knowledge Holder names available from DAA
	2953	Tjitji Ngarlparringu	File and Boundary Restricted No Gender Restrictions	Registered Site	Ceremonial, Mythological	Registered Knowledge Holder names available from DAA

Notes:

- These places/sites have all been assessed as meeting Section 5 of the *Aboriginal Heritage Act 1972* (WA)
- Our WA Searches did not indicate any registered places/sites of Aboriginal heritage or significance located on the other WA Tenements



Part 2: Western Australia – Other Aboriginal Heritage Places

Our searches of AHIS indicate that Other Aboriginal Heritage Places have been listed in respect of the following WA Tenements.

Tenement	Site ID ar	Site Name	Restrictions	Status	Type	Knowledge Holders
E69/535	1391	YILIPALKU	File and Boundary Restricted No Gender Restrictions	Stored Data Not a Site	Artefacts / Scatter, Mythological	Registered Knowledge Holder names available from DAA
	2820	YAPPA	File and Boundary Restricted No Gender Restrictions	Stored Data Not a Site	Ceremonial, Man-Made Structure, Mythological	Registered Knowledge Holder names available from DAA
	2821	WEEPIN	File and Boundary Restricted No Gender Restrictions	Stored Data Not a Site	Mythological	Registered Knowledge Holder names available from DAA
	2900	JILIBALGU 1	File and Boundary Restricted No Gender Restrictions	Stored Data Not a Site	Mythological	Registered Knowledge Holder names available from DAA
	25152	Wingellina Scatter 1	No File and Boundary Restriction No Gender Restrictions	Lodged	Artefacts / Scatter	Registered Knowledge Holder names available from DAA
	25153	Wingellina Scatter 2	No File and Boundary Restrictions No Gender Restrictions	Lodged	Artefacts / Scatter, Grinding Patches / Grooves	Registered Knowledge Holder names available from DAA
	25154	Wingellina Scatter 3	No File and Boundary Restrictions No Gender Restrictions	Lodged	Artefacts / Scatter, Grinding Patches / Grooves	Registered Knowledge Holder names available from DAA
	25155	Wingellina Scatter 4	No File and Boundary Restrictions No Gender Restrictions	Lodged	Artefacts / Scatter, Grinding Patches / Grooves	Registered Knowledge Holder names available from DAA
	25156	Wingellina Scatter 5	No File and Boundary Restrictions No Gender Restrictions	Lodged	Artefacts / Scatter, Other: Isolated grinding material	Registered Knowledge Holder names available from DAA
	25157	Wingellina Scatter 6	No File and Boundary Restrictions No Gender Restrictions	Lodged	Artefacts / Scatter	Registered Knowledge Holder names available from DAA
	25158	Wingellina Scatter 7	No File and Boundary Restrictions No Gender Restrictions	Lodged	Artefacts / Scatter	Registered Knowledge Holder names available from DAA
25159	Wingellina Scatter 8	No File and Boundary Restrictions No Gender Restrictions	Lodged	Artefacts / Scatter, Grinding Patches / Grooves	Registered Knowledge Holder names available from DAA	

personal use only



SCHEDULES TO SOLICITORS' REPORT ON TENEMENTS
NICO Resources Limited

Part 2: Western Australia – Other Aboriginal Heritage Places (cont)

Tenement	Site ID ar	Site Name	Restrictions	Status	Type	Knowledge Holders
E69/535	25160	Wingellina Scatter 9	No File and Boundary Restrictions No Gender Restrictions	Lodged	Artefacts / Scatter	Registered Knowledge Holder names available from DAA
	25161	Wingellina Scatter 10	No File and Boundary Restrictions No Gender Restrictions	Lodged	Artefacts / Scatter	Registered Knowledge Holder names available from DAA
	25162	Wingellina Scatter 11	No File and Boundary Restrictions No Gender Restrictions	Lodged	Artefacts / Scatter	Registered Knowledge Holder names available from DAA
	25163	Wingellina Scatter 12	No File and Boundary Restrictions No Gender Restrictions	Lodged	Artefacts / Scatter	Registered Knowledge Holder names available from DAA
	25164	Wingellina Scatter 13	No File and Boundary Restrictions No Gender Restrictions	Lodged	Artefacts / Scatter	Registered Knowledge Holder names available from DAA
	25165	Wingellina Scatter 14	No File and Boundary Restrictions No Gender Restrictions	Lodged	Artefacts / Scatter	Registered Knowledge Holder names available from DAA
	25166	Wingellina Scatter 15	No File and Boundary Restrictions No Gender Restrictions	Lodged	Artefacts / Scatter, Grinding Patches / Grooves	Registered Knowledge Holder names available from DAA
	25167	Wingellina Scatter 16	No File and Boundary Restrictions No Gender Restrictions	Lodged	Artefacts / Scatter	Registered Knowledge Holder names available from DAA
	25168	Wingellina Scatter 17	No File and Boundary Restrictions No Gender Restrictions	Lodged	Artefacts / Scatter	Registered Knowledge Holder names available from DAA
	25169	Wingellina Scatter 18	No File and Boundary Restrictions No Gender Restrictions	Lodged	Artefacts / Scatter	Registered Knowledge Holder names available from DAA
	25170	Wingellina Scatter 19	No File and Boundary Restrictions No Gender Restrictions	Lodged	Artefacts / Scatter	Registered Knowledge Holder names available from DAA
	25171	Wingellina Scatter 20	No File and Boundary Restrictions No Gender Restrictions	Lodged	Artefacts / Scatter, Grinding Patches / Grooves, Modified Tree	Registered Knowledge Holder names available from DAA
25172	Wingellina Scatter 21	No File and Boundary Restrictions No Gender Restrictions	Lodged	Artefacts / Scatter, Grinding Patches / Grooves	Registered Knowledge Holder names available from DAA	



SCHEDULES TO SOLICITORS' REPORT ON TENEMENTS
NICO Resources Limited

Part 2: Western Australia – Other Aboriginal Heritage Places (cont)

Tenement	Site ID ar	Site Name	Restrictions	Status	Type	Knowledge Holders
E69/535	25173	Wingellina Knapping 1	No File and Boundary Restrictions No Gender Restrictions	Lodged	Artefacts / Scatter, Quarry	Registered Knowledge Holder names available from DAA
	25174	Wingellina Knapping 2	No File and Boundary Restrictions No Gender Restrictions	Lodged	Artefacts / Scatter, Quarry	Registered Knowledge Holder names available from DAA
	25175	Wingellina Knapping 3	No File and Boundary Restrictions No Gender Restrictions	Lodged	Artefacts / Scatter	Registered Knowledge Holder names available from DAA
	25176	Wingellina Knapping 4	No File and Boundary Restrictions No Gender Restrictions	Lodged	Artefacts / Scatter, Quarry	Registered Knowledge Holder names available from DAA
	25177	Wingellina Knapping 5	No File and Boundary Restrictions No Gender Restrictions	Lodged	Artefacts / Scatter, Quarry	Registered Knowledge Holder names available from DAA
	25178	Wingellina Grinding 1	No File and Boundary Restrictions No Gender Restrictions	Lodged	Artefacts / Scatter, Grinding Patches / Grooves	Registered Knowledge Holder names available from DAA
	25179	Wingellina Grinding 2	No File and Boundary Restrictions No Gender Restrictions	Lodged	Artefacts / Scatter, Grinding Patches / Grooves	Registered Knowledge Holder names available from DAA
	25180	Wingellina Grinding 3	No File and Boundary Restrictions No Gender Restrictions	Lodged	Artefacts / Scatter, Grinding Patches / Grooves	Registered Knowledge Holder names available from DAA
	25181	Wingellina Grinding 4	No File and Boundary Restrictions No Gender Restrictions	Lodged	Artefacts / Scatter, Grinding Patches / Grooves	Registered Knowledge Holder names available from DAA
	25182	Wingellina Arrangement 1	No File and Boundary Restrictions No Gender Restrictions	Lodged	Man-Made Structure	Registered Knowledge Holder names available from DAA
	25183	Wingellina Arrangement 2	No File and Boundary Restrictions No Gender Restrictions	Lodged	Man-Made Structure	Registered Knowledge Holder names available from DAA
	25184	Wingellina Arrangement 3	No File and Boundary Restrictions No Gender Restrictions	Lodged	Man-Made Structure	Registered Knowledge Holder names available from DAA
	25185	Wingellina Stone Structure 1	No File and Boundary Restrictions No Gender Restrictions	Lodged	Artefacts / Scatter, Man-Made Structure	Registered Knowledge Holder names available from DAA



SCHEDULES TO SOLICITORS' REPORT ON TENEMENTS
NICO Resources Limited

Part 2: Western Australia – Other Aboriginal Heritage Places (cont)

Tenement	Site ID ar	Site Name	Restrictions	Status	Type	Knowledge Holders
E69/535	25186	Wingellina Engraving 1	No File and Boundary Restrictions No Gender Restrictions	Lodged	Engraving	Registered Knowledge Holder names available from DAA
	36679	Urryurpi	File and Boundary Restricted Female Access Only	Lodged	Ceremonial, Historical, Mythological	Registered Knowledge Holder names available from DAA
	36680	Papa Purrtjuta Ngurra	File and Boundary Restricted Unknown other restrictions	Lodged	Mythological	Registered Knowledge Holder names available from DAA

Notes:

- The status of four of these sites is listed as “Stored Data / Not a Site” meaning the place has been assessed as not meeting section 5 of the *Aboriginal Heritage Act 1972* (WA).
- The status of the remaining 37 of these sites is listed as “Lodged” meaning information has been received in relation to the place, but an assessment has not been completed at this stage to determine if it meets section 5 of the *Aboriginal Heritage Act 1972* (WA).
- Our WA Searches did not indicate any unregistered places/sites of Aboriginal heritage or significance located on the other WA Tenements.



SCHEDULES TO SOLICITORS' REPORT ON TENEMENTS
NICO Resources Limited

Part 3: Western Australia – Heritage Surveys

Our searches of AHIS indicate that Heritage Surveys have only been conducted over the following WA Tenements.

Tenement	Survey Report ID	Report Title	Area Number	Survey Type	Area Description	Spatial Accuracy
E69/535 L69/27	22092	The chrysoprase and moss agate deposits at Wingellina and Mt Davies in the north-western region of the Musgrave range in central Australia	1	Archaeological & Ethnographic	At Wingellina and Mt Davies in the north-western region of the Musgrave range in central Australia.	Unreliable
E69/535 L69/27	22302	Work program clearance for Metex Nickel Pty Ltd EL69/535 tenement	1	Ethnographic	Metex Nickel Pty Ltd EL69/535 tenement	Moderate
E69/535 L69/27	23016	Archaeological survey of Tenement E69/535, Irrunytju Community, Ngaanyatjarra Lands	1	Archaeological	Mining Tenement - E69/535	Good
E69/535	103368	Visit to the Great Victoria Desert (South and Western Australia) September-October 1966.	1	Archaeological	The survey area comprises Aboriginal sites in the Great Victoria Desert - DIA IDs 1332, 2740, 2784, 2847, 3083, 3121	Indeterminate
		Visit to the Great Victoria Desert (South and Western Australia) September-October 1966.	2	Archaeological	The survey area comprises heritage locations in the Great Victoria Desert - Closed sites:1391, 2747, 2788, 2888, 2889, 2891, 2901, 2902, 3046 and 3057. The survey area location and extent are as per the AHMS and are indeterminate due to restrictions.	Indeterminate

Notes:

- Our WA Searches did not indicate any Heritage Surveys as having been conducted on the other WA Tenements.



SCHEDULES TO SOLICITORS' REPORT ON TENEMENTS
NICO Resources Limited

Part 4: South Australia – Aboriginal Sites and Objects

Our searches indicate that Aboriginal sites and objects have only been registered over the following SA Tenements.

Tenement	Map Number	Site Number	Site Type	Area / Point	Site Status	Restricted
EL 5860	4745	17	Cultural	Point	Registered	Yes
		18	Cultural	Point	Registered	Yes
		430	Cultural	Point	Registered	Yes

Notes:

- Our SA Searches did not indicate any registered Aboriginal sites and objects located on the other SA Tenement.

personal use only



Schedule 5 – Agreements affecting Tenements

Tenement Affected	Agreement Description	Summary of Terms
WA Indigenous Agreements		
E69/535 E69/3065 L69/12 L69/19 L69/27	Wingellina Project Agreement dated 15 July 2010 between Hinckley Range, Yarnangu Ngaanyatjarraku Parna (Aboriginal Corporation) (YNP), Ngaanyatjarra Land Council (Aboriginal Corporation) (NLC) and Ngaanyatjarra Council (Aboriginal Corporation) (NC) and registered by the NNTT as an Indigenous Land Use Agreement on 21 October 2011 (ILUA ID: WI2011/007) (Wingellina ILUA)	<p>The Wingellina ILUA sets out the rights and obligations of all parties in relation to the conduct of the Project, being the mining and processing of nickel and cobalt ores from within a designated area, within which we are informed by the Company that all the WA Tenements are located.</p> <p>Hinckley Range is obliged to adhere to the terms of the Wingellina ILUA in carrying out its exploration and mining activities in respect of the Project.</p> <p>The Wingellina ILUA provides for various aspects of the Project, including the grant of mining leases, construction and operation of the mine site and processing facilities, location of infrastructure and associated compensation payments. It sets out the process and rules which the parties will be obliged to comply with in order for Hinckley Range to conduct its operations, including (without limitation) land access and entry permitting, tenure approval and grant, conduct of works, location of infrastructure, cultural protection protocols and management plans, audit rights, governance requirements for all parties, employment opportunities and education to Ngaanyatjarra People, environmental requirements and remedial actions and relocation of the community.</p> <p>While a number of payments have already been made under the Wingellina ILUA, further compensation payments will be required by Hinckley Range to YNP following the announcement of a final investment decision being made in respect of the Project. Hinckley Range is also required to make payments to YNP on account of anthropological costs, administrative and other expenses associated with the implementation of the matters contained in the Wingellina ILUA.</p> <p>Due to standard confidentiality provisions, the terms and conditions of indigenous land use agreements are not available for public access or dissemination.</p>

personal use only



SCHEDULES TO SOLICITORS' REPORT ON TENEMENTS
NICO Resources Limited

Tenement Affected	Agreement Description	Summary of Terms
<i>WA Indigenous Agreements (cont)</i>		
E69/3065	Ngaantayjarra Lands (Part III Reserves) Mineral Exploration Access Agreement dated 20 February 2013 between Hinckley Range, NC, NLC and YNP (Access Agreement)	<p>The Access Agreement sets out the process and rules under which Hinckley Range can enter onto and conduct exploration within the area of E69/3065. These include (without limitation) compliance with the Aboriginal Heritage Protocols set out in the Wingellina ILUA, heritage protection, conduct of airborne surveys, giving preference to Ngaanyatjarra People and entities and reporting obligations.</p> <p>Hinckley Range is also required to make payments to NC on account of their administrative and other expenses.</p> <p>No mining is authorised under this agreement.</p> <p>The Access Agreement is not intended to amend or modify the Wingellina ILUA and in the event of any inconsistency between the Access Agreement and the Wingellina ILUA, the terms of the Wingellina ILUA will prevail except in regard to any exploration on the area of E69/3065 by Hinckley Range.</p>
E69/535 L69/12	Deed of Agreement dated 2 July 2001 between Hinckley Range, the NLC and Stanley Mervyn (on behalf of the Irrunytju Papulankutua being the registered native title applicant at the time) (Exploration Agreement)	<p>The Exploration Agreement sets out the process and rules under which Hinckley Range could enter onto and conduct exploration within E69/535.</p> <p>As a result of the parties entering into the Wingellina ILUA, the Exploration Agreement:</p> <ul style="list-style-type: none"> (a) is currently suspended and of no force or effect other than in respect of continued annual payments; and (b) will be terminated upon the commencement of certain compensation payments outlined under the Wingellina ILUA. <p>Matters relating to the conduct of activities within E69/535 are addressed under the Wingellina ILUA.</p>



SCHEDULES TO SOLICITORS' REPORT ON TENEMENTS
NICO Resources Limited

Tenement Affected	Agreement Description	Summary of Terms
WA Indigenous Agreements (cont)		
L69/12	Deed of Agreement dated 19 June 2008 between Hinckley Range, NC, NLC and YNP (Water Agreement)	<p>The Water Agreement sets out the processes and rules under which Hinckley Range could enter onto and conduct searches for ground water within the area of L69/12 and L69/13.</p> <p>As a result of the parties entering into the Wingellina ILUA, the Water Agreement is currently suspended and of no force or effect, and will remain so while the Wingellina ILUA is in effect other than in respect of:</p> <ul style="list-style-type: none"> (a) specified clauses regarding environmental protection and rehabilitation, groundwater monitoring; and (b) all obligations that accrued prior to the commencement of the Wingellina ILUA, which continue to apply to the parties. <p>Matters relating to the continued search for groundwater are addressed under the Wingellina ILUA to the extent such activities are not within the continued scope of the Water Agreement.</p>
E69/535 E69/3065 L69/12 L69/19 L69/27	Wingellina Project Agreement Parent Company Guarantee dated 16 July 2010 between MLX, YNP, NLC and NC (Wingellina PCG)	<p>Certain payments and obligations due by Hinckley Range to YNP, NC and NLC under the Wingellina ILUA are currently secured and guaranteed by MLX by the Wingellina PCG.</p> <p>The Wingellina PCG will continue to operate until the earlier of MLX being released from its obligations under the Wingellina PCG (by the assignment and assumption of MLX's obligations to NICO) and Hinckley Range being released from those obligations under the Wingellina ILUA which are secured by parent company guarantee.</p> <p>Upon completion occurring under the Share Sale Agreement, the Company has agreed to indemnify MLX against any claims incurred by or against MLX or arising in connection with MLX's obligations under the Wingellina PCG.</p>

personal use only



SCHEDULES TO SOLICITORS' REPORT ON TENEMENTS
NICO Resources Limited

Tenement Affected	Agreement Description	Summary of Terms
<i>SA Indigenous Agreements</i>		
EL 6240	Deed of Exploration dated 1 February 2006 between APY, Delta Gold Limited (Delta) and Rio Tinto Exploration Pty Ltd (Rio), as assigned and assumed (February 2006 APY Agreement)	<p>Austral Nickel became a party to the February 2006 APY Agreement via a series of transactions. The conditions attached to the grant of EL 6240 also specifically require that Austral Nickel abide by the terms of the February 2006 APY Agreement.</p> <p>This agreement sets out the various processes and rules under which Austral Nickel may enter onto and conduct exploration on EL 6240 within APY lands. This includes (without limitation) submitting proposed work programs, undertaking heritage clearance surveys, land access and entry permits, exploration payments, environmental matters and rehabilitation, and employment and training of aboriginal workers.</p> <p>While no mining operations are permitted to be undertaken by Austral Nickel under this agreement, it does provide a process for consultations with the APY regarding mining proposals and the process for the development of a mining agreement in the future.</p> <p>This agreement also provides for a number of payments to be made by Austral Nickel to APY in respect of annual exploration, use of roads/airstrip, water use and maintenance and administration.</p>
EL 5860	Deed of Exploration dated 18 May 2006 between APY and Austral Nickel (May 2006 APY Agreement)	<p>Austral Nickel is a direct party to the February 2006 APY Agreement. The conditions attached to the grant of EL 5860 also specifically require that Austral Nickel abide by the terms of the May 2006 APY Agreement.</p> <p>This agreement sets out the various processes and rules under which Austral Nickel may enter onto and conduct exploration on EL 5860 within APY lands. This includes (without limitation) submitting proposed work programs, undertaking heritage clearance surveys, land access and entry permits, exploration payments, environmental matters and rehabilitation, and employment and training of aboriginal workers.</p> <p>While no mining operations are permitted to be undertaken by Austral Nickel under this agreement, it does provide a process for consultations with the APY regarding mining proposals and the process for the development of a mining agreement in the future.</p> <p>This agreement also provides for a number of payments to be made by Austral Nickel to APY in respect of annual exploration, use of roads/airstrip, water use and maintenance and administration.</p>



SCHEDULES TO SOLICITORS' REPORT ON TENEMENTS
NICO Resources Limited

Tenement Affected	Agreement Description	Summary of Terms
Royalties		
E69/535 E69/3065 L69/12 L69/19 L69/27 EL 6240 EL 5860	Royalty Deed between MLX, Austral Nickel and Hinckley Range dated 17 May 2021 (MLX Royalty Deed)	Hinckley Range and Austral Nickel have agreed to grant a 1.75% net smelter return royalty to MLX. This royalty is payable in respect of any mineral or metallic product extracted or recovered from the area of the WA Tenements and the SA Tenements, which is capable of being sold or otherwise disposed of. The MLX Royalty Deed otherwise contains terms and conditions considered standard for agreements of this nature.
EL 6240	Giles Complex Royalty Deed between Rio Delta and Delta Gold Exploration Pty Ltd dated 8 April 1998, as assigned and assumed (Giles Royalty Deed)	Following a series of transactions, Barrick (PD) Australia Pty Ltd is the current holder of a royalty equal to 1.5% of gross sale revenue received by Austral Nickel. This royalty is payable in respect of any marketable mineral or other commodities recovered or produced from that part of EL 6240 as informed to us by the Company. The Giles Royalty Deed otherwise contains terms and conditions considered standard for agreements of this nature.

personal use only

For personal use only

Schedule 3

– Independent Technical
Assessment Report



CSA Global
Mining Industry Consultants
an ERM Group company

NICO RESOURCES LIMITED

**Technical Assessment
Report of the Central
Musgrave Nickel-Cobalt
Project**

REPORT N° R308.2021
30 August 2021

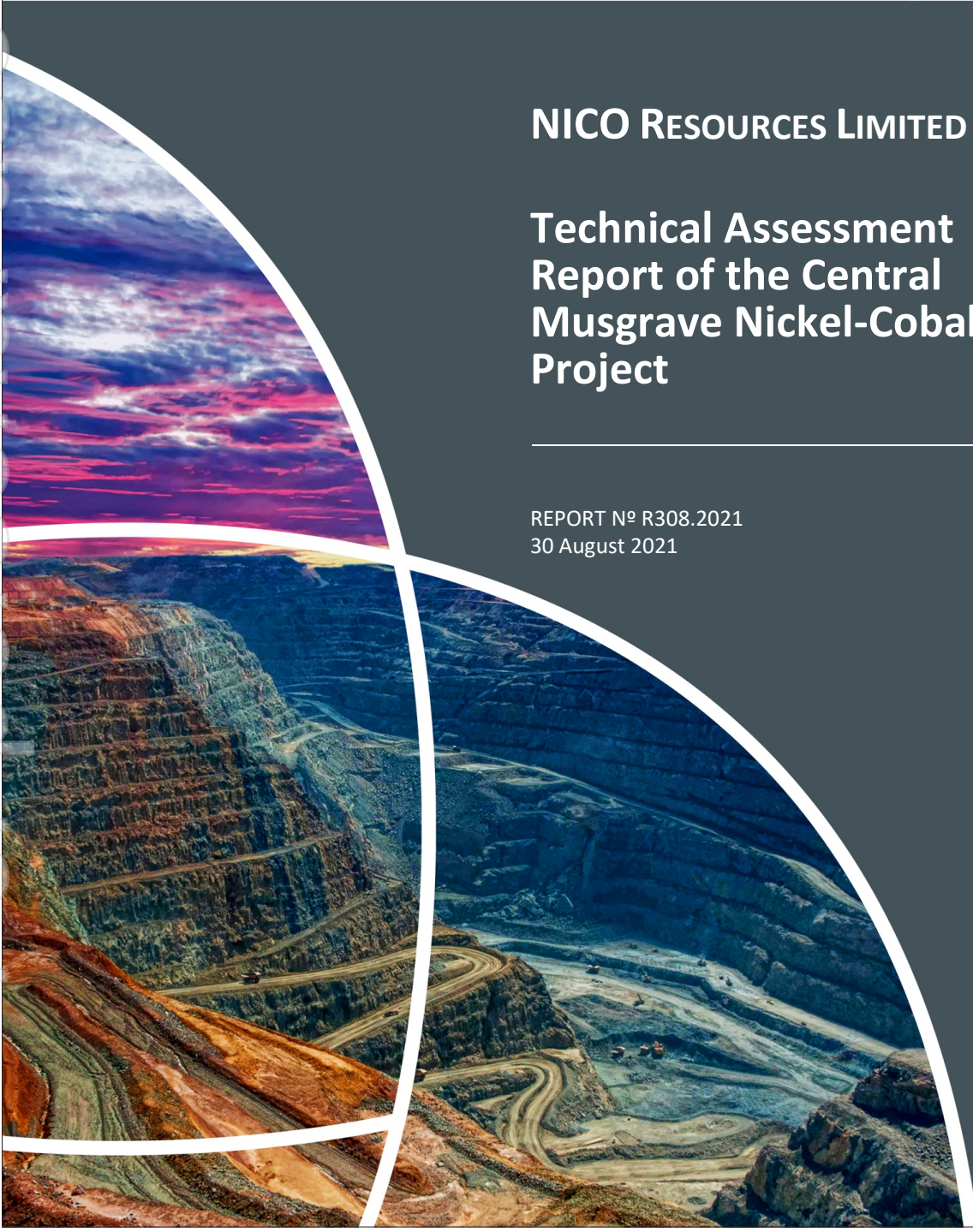

For personal use only

NICO RESOURCES LIMITED
TECHNICAL ASSESSMENT REPORT



Report prepared for

Client Name	NICO Resources Limited
Project Name/Job Code	NICITA01
Contact Name	Warren Hallam
Contact Title	Chairman
Office Address	Level 11 London House, 216 St Georges Terrace, Perth WA 6000, Australia

Report issued by

CSA Global Office	<p>CSA Global Pty Ltd Level 2, 3 Ord Street West Perth WA 6005 AUSTRALIA</p> <p>T +61 8 9355 1677 F +61 8 9355 1977 E info@csaglobal.com</p>
Division	Corporate

Report information

Filename	R308.2021 NICITA01 NICO TAR - Final 20211105
Last Edited	8/11/2021 3:11:00 PM
Report Status	Final

Author and Reviewer Signatures

Coordinating Author	Ivy Chen BAppSc (Geology), Postgrad Dip. Nat Res., FAusIMMM, GAICD	Electronic signature not for duplication. Electronic signature not for duplication. Electronic signature not for duplication. Electronic signature not for duplication. Electronic signature not for duplication. Electronic signature not for duplication.
Contributing Author	Tony Donaghy BSc (Hons), Associate Diploma of Civil Engineering, P.Geo.	Electronic signature not for duplication. Electronic signature not for duplication. Electronic signature not for duplication. Electronic signature not for duplication. Electronic signature not for duplication. Electronic signature not for duplication.
Contributing Author	Mark Laing BEng (Mining) Hons, MAusIMM	Electronic signature not for duplication. Electronic signature not for duplication. Electronic signature not for duplication. Electronic signature not for duplication. Electronic signature not for duplication. Electronic signature not for duplication.
Peer Reviewer	Mick Elias BSc (Hons) Geology, FAusIMM (CP), MGSA	Electronic signature not for duplication. Electronic signature not for duplication. Electronic signature not for duplication. Electronic signature not for duplication. Electronic signature not for duplication. Electronic signature not for duplication.
CSA Global Authorisation	Graham Jeffress BSc (Hons) Applied Geology, RPGeo (Mineral Exploration), FAIG, FAusIMM, FSEG, MGSA	Electronic signature not for duplication. Electronic signature not for duplication. Electronic signature not for duplication. Electronic signature not for duplication. Electronic signature not for duplication. Electronic signature not for duplication.

© Copyright 2021

For personal use only



Executive Summary

CSA Global Pty Ltd (CSA Global), an ERM Group company, was requested by NICO Resources Limited (NICO) to prepare a Technical Assessment Report (“Report”) for use in a prospectus to support the acquisition of the Wingellina Nickel Project (“Wingellina Project” or “Wingellina”), the Claude Hills Nickel Project (“Claude Hills Project”, or “Claude Hills”) and Mount Davies Nickel Project (“Mount Davies Project” or “Mount Davies”), collectively, the Central Musgrave Project (“CMP” or the “Project”) – Figure 1 – from Metals X Limited (Metals X, or MLX).

The CMP comprises two lateritic nickel-cobalt resource areas; Wingellina located within Western Australia and Claude Hills located within South Australia. NICO intends to undertake an initial public offering (IPO) and seek a listing on the Australian Securities Exchange (ASX). The funds raised will be used for the exploration and evaluation of the project areas.

Central Musgrave Project

NICO will hold a 100% interest in the CMP through the wholly-owned subsidiaries of Metals Exploration of Hinckley Range Pty Ltd in Western Australia and Austral Nickel Pty Ltd in South Australia. The CMP comprises four granted Exploration Licences (E69/0535 and E69/3065 in Western Australia; EL5860 and EL6240 in South Australia) and three granted Miscellaneous Licences (L69/0012, L69/0019 and L69/0027 in Western Australia). The seven tenements combined cover a total area of 1,468.6 km².

The CMP represents a good opportunity to evaluate development options for the economic extraction of nickel, cobalt and scandium from the significant laterite profile developed over ultramafic lithologies of the Giles Complex at Wingellina and Claude Hills. The Project comprises advanced exploration with significant resources identified and a range of mining, processing and saleable product options identified for further evaluation as to their economic potential. The Project has good potential, but further work is required.

The CMP has a long history of exploration for nickel laterite dating back to the 1960s, culminating in a Mineral Resource estimate compliant with the JORC Code 2012 (Table 1).

NICO RESOURCES LIMITED
TECHNICAL ASSESSMENT REPORT



Table 1: Mineral Resource estimation for the Wingellina Project

0.5% Ni cut-off grade	Classification	2008			2016 Metals X			% Difference tonnes	% Difference metal
		Tonnes	Grade	Metal	Tonnes	Grade	Metal (t)		
Wingellina									
Nickel	Measured	68,847,000	1.00	688,500	37,600,000	0.98	368,000	-45%	-47%
	Indicated	98,623,000	0.97	956,600	130,900,000	0.91	1,193,000	33%	25%
	Inferred	15,727,000	0.97	152,600	14,100,000	0.87	122,000	-10%	-20%
	Total	183,197,000	0.98	1,798,000	182,600,000	0.92	1,684,000	0%	-6%
Cobalt	Measured	68,847,000	0.08	53,700	37,600,000	0.075	28,000	-45%	-48%
	Indicated	98,623,000	0.08	74,000	130,900,000	0.072	94,600	33%	28%
	Inferred	15,727,000	0.07	11,000	14,100,000	0.065	9,100	-10%	-16%
	Total	183,197,000	0.08	138,700	182,600,000	0.07	131,700	0%	-5%
Fe ₂ O ₃	Measured	68,847,000	48.71	33,535,000	37,600,000	45.94	17,260,000	-45%	-49%
	Indicated	98,623,000	46.39	45,751,000	130,900,000	45.55	59,611,000	33%	30%
	Inferred	15,727,000	42.73	6,720,000	14,100,000	41.25	5,832,000	-10%	-13%
	Total	183,197,000	46.95	86,006,000	182,600,000	45.30	82,701,000	0%	-4%
Claude Hills 2010									
Nickel	Measured	-	-	-	-	-	-	-	-
	Indicated	-	-	-	-	-	-	-	-
	Inferred	-	-	-	33,000,000	0.81	270,000	-	-
	Total	-	-	-	33,000,000	0.81	270,000	-	-
Cobalt	Measured	-	-	-	-	-	-	-	-
	Indicated	-	-	-	-	-	-	-	-
	Inferred	-	-	-	33,000,000	0.07	22,700	-	-
	Total	-	-	-	33,000,000	0.07	22,700	-	-
Total Central Musgrave Project									
Nickel	Total	-	-	-	215,600,000	0.91	1,954,000	-	-
Cobalt	Total	-	-	-	215,600,000	0.07	154,400	-	-

Notes: Mineral Resources are reported inclusive of Mineral Resources modified to produce the Ore Reserve.

Figures have been rounded to the appropriate number of significant figures.

The 2016 MLX MRE was reported in accordance with the current 2012 edition of the JORC Code

The 2008 Wingellina MRE and 2010 Claude Hills MRE were reported in accordance with the 2004 edition of the JORC Code

Source: Metals X (2017)

There was an Ore Reserve declared by Metals X as of 30 June 2016 (Table 2).

Table 2: Ore Reserve estimation for the Wingellina Project

Project	Ore Reserve category ¹	Ore (Mt)	Nickel		Cobalt	
			Grade (% Ni)	Nickel (kt Ni ²)	Grade (% Co)	Cobalt (kt Co ²)
Wingellina	Proved	-	-	-	-	-
	Probable	168.4	0.93%	1,561	0.07%	122.6
	Total	168.4	0.93%	1,561	0.07%	122.6

Notes:

- The Ore Reserve is based on the Wingellina Mineral Resource estimate as of 30 June 2016 with applied modifying factors, at a cut-off grade of 0.5% Ni.
- Tonnes are reported as million tonnes (Mt) and rounded to nearest 100,000; nickel tonnes are reported as thousand tonnes (kt) and rounded to the nearest 1,000 tonnes; cobalt tonnes are reported as thousand tonnes (kt) and rounded to the nearest 100 tonnes; rounding may result in some slight apparent discrepancies in totals.

Source: Metals X (2016).

CSA Global is of the opinion that the 2016 Metals X Mineral Resource estimation parameters, methodologies and conclusions are in accordance with good industry practice and the JORC Code guidelines. A detailed peer



review of the resource model is recommended to examine all relevant parameters in the updated Mineral Resource estimate. With expected changes to these parameters and other modifying factors, it is anticipated a new Ore Reserve estimate would need to be declared with an updated Pre-feasibility Study (PFS).

A Feasibility Study was conducted for the Wingellina Project in 2008. CSA Global has reviewed this work, as well as a range of other process technology, mining and product option studies conducted by Metals X since 2008. CSA has reviewed the validity of the Ore Reserves which were compiled in 2016 and is of the view that the Reserves are valid and have been reported in accordance with the JORC Code.

CSA Global has made a series of recommendations on the best approach required to update the results of these studies and move the Project forward to a PFS-level of confidence in accordance with the JORC and VALMIN reporting standards and regulatory requirements of the Australian Securities and Investments Commission (ASIC) and ASX. It is understood that NICO plans to carry out the required work to advance the project to PFS within the first two years after listing.

Exploration potential in the CMP is in three broad categories of confidence level:

- 1) Delineation of cohesive domains of higher-grade material within the existing resource envelopes at Wingellina and Claude Hills for metals of interest such as nickel, cobalt, and scandium. The presence of such cohesive domains of higher-grade material could potentially allow a favourable start-up scenario for extraction.
- 2) Continuation of the laterite mineralisation systems beyond the current resource envelopes at Wingellina and Claude Hills.
- 3) Regional exploration for other mineralised systems within the current exploration leases.

Other work is also required to delineate the calcrete resource at Lewis for potential use in the laterite extractive process system flowchart. Current drilling has only covered approximately 20% of the outlined calcrete system mapped at surface.

Risks

A key risk, common to all exploration companies, is that expected mineralisation may not be present or that it may be too low-grade or too small to warrant commercial exploitation.

The ability of any project to achieve forward-looking production and economic targets is dependent on numerous factors that are beyond CSA Global's control and that CSA Global cannot anticipate. These factors include, but are not limited to, site-specific mining and geological conditions, management and personnel capabilities, availability of funding to properly operate and capitalize the operation, variations in cost elements and market conditions, developing and efficiently operating the mine, unforeseen changes in legislation and new industry developments. Any of these factors may substantially alter the performance of any mining operation.

The interpretations and conclusions reached in this Report are based on current geological understanding and the best evidence available to the authors at the time of writing. It is the nature of all scientific conclusions that they are founded on an assessment of probabilities and, however high these probabilities might be, they cannot provide absolute certainty.

CSA Global cannot guarantee certainty regarding the future economic viability of the Project. NICO plans to conduct the economic and engineering studies required to determine the economic viability of the CMP.

The CMP comprises a range of stages of advancement from early exploration through to advanced exploration. Risk is reduced at each stage. Exploration is an intrinsically risky process, particularly at an early-stage.

The Closure Management Plan falls within Aboriginal land both within Western Australia and South Australia. CSA Global understands there is a mining agreement in place, and the Company conducts regular consultation meetings with the community involved. NICO will need to maintain good working relationships with the local communities to maintain access for work, and may require additional formal agreements for



any future development works. There will be a need to consider the potential impact of an operating mine site on the nearby Wingellina community. The impact of mining and processing operations, which potentially include impacted by dust, noise and other emissions were considered as part of the EPA approval which was received in 2016, and will need to be monitored on an on-going basis, and any impacts mitigated. CSA Global notes that the EPA approval was granted 01/09/2016 and there is a 5 year time limit on substantial commencement, and a possibility exist that the EPA approval may be reassessed.

Archaeological sites and heritage exclusion zones may sometimes represent a restriction to mining operations. However, in this instance, Metals X has completed significant archaeological studies which have delineated the sensitive sites and heritage exclusion zones. Metals X has mining agreement with the local Aboriginal landholder group in place covering 18,000sq kms for mining, water, roads and other infrastructure. The Company is aware that that this broad scale agreement may need to be refined as project development progresses, should any localised site specific issues arise.

The processing testwork conducted to date is considered to be at a PFS level. Further processing testwork including geometallurgical studies is required. CSA Global notes that Metals X has commenced this body of work.

Designing, building and operating nickel laterite plants is a complex process and comprises numerous risks from a design, construction, operation, environmental and occupational health and safety standpoint. Project delays, cost overruns, processing issues, increased operational costs etc. have the potential to negatively impact the project value. Detailed feasibility studies at the appropriate stages of project maturity will be completed to manage and contain these risks. The site is isolated, and this represents logistical challenges for developing and operating a mine and processing facilities.

Further investigation of a firm market for the nickel and cobalt products is needed. The end product can be varied to suit the market, and at this stage of the Project long-term forecasts for product demand and pricing carries inherent risks from unforeseen external circumstances affecting future market conditions.

Long-term metal prices should be reviewed, and the pit optimisation updated as a significant change in metals pricing assumptions would make a material impact on the pit and waste designs. More detailed mine scheduling of the process feed material will improve the optimised output by maximising grade and reducing variability.

Use of Funds

NICO provided CSA Global with a copy of its planned expenditure for the CMP for an initial two-year period following listing on the ASX (Table 3). CSA Global understands the budget in Table 3 will be scaled proportionally based on any oversubscription funds raised. All costs included are in Australian dollars (A\$).

Table 3: Proposed exploration expenditure summary by activity

Use of funds	Year 1	Year 2
Drilling and assays	\$450,700	\$854,400
Contractors, consultants and staff	\$556,100	\$532,000
Land access and compensation	\$200,400	\$192,000
Travel to site	\$200,000	\$200,000
Permits, rents and rates	\$77,100	\$76,200
Supplies and other	\$100,300	\$140,000
Feasibility studies	\$259,200	\$259,000
Directors' fees and remuneration	\$400,000	\$400,000
General administration & working capital	\$786,200	\$586,200
Capital	\$12,000	\$12,000
Future Acquisitions	\$850,000	\$500,000
Estimated Expenditure of Offer	\$928,100	0
Transfer duty	\$260,000	-

NICO RESOURCES LIMITED
TECHNICAL ASSESSMENT REPORT



Total funds allocated	\$5,080,100	\$3,751,800
-----------------------	-------------	-------------

NICO has prepared staged exploration and evaluation programs, specific to the potential of the CMP, which are consistent with the budget allocations, and warranted by the exploration and technical potential of the CMP. CSA Global considers that the relevant areas have sufficient technical merit to justify the proposed programs and associated expenditure. The budgeted expenditure is also considered sufficient to meet the minimum statutory expenditure on the tenements.

For personal use only



Contents

Report prepared for	I
Report issued by	I
Report information	I
Author and Reviewer Signatures	I
EXECUTIVE SUMMARY	II
Central Musgrave Project	II
Risks IV	
Use of Funds	V
1 INTRODUCTION	1
1.1 Context, Scope and Terms of Reference	1
1.2 Compliance with the VALMIN and JORC Codes	2
1.3 Principal Sources of Information and Reliance on Other Experts	2
1.4 Prior Association and Independence	3
1.5 Authors of the Report	3
1.6 Declarations	4
1.6.1 Competent Person's Statement	5
1.6.2 No Site Inspection	5
2 PROJECT TENURE AND LOCATION	6
3 MINERALISATION AND GEOLOGY	8
3.1 Mineralisation Model	8
3.2 Geology	9
3.2.1 Regional Geology	9
3.2.2 Local Geology and Mineralisation – Wingellina	13
3.2.3 Local Geology and Mineralisation – Claude Hills	16
3.2.4 Local Geology and Mineralisation – Lewis Calcrete	17
4 PREVIOUS EXPLORATION	19
4.1 Wingellina Laterite	19
4.1.1 Southwestern Mining Ltd, Nickel Mines of Australia NL – 1956 to 1975	19
4.1.2 Hinckley Range Pty Ltd (Acclaim Exploration Ltd and Metals X Ltd) – 2000 to 2008	19
4.2 Claude Hills/Mount Davies Laterite	20
4.3 Mount Davies Regional	20
4.4 Lewis Calcrete	21
5 MINERAL RESOURCES	22
5.1 Previous Resource Estimates	22
5.2 2016 Mineral Resource and Reserve Estimate	23
6 MINERAL PROCESSING STUDIES	25
6.1 Aker Feasibility Study	25
6.2 Metallurgical Testwork for 2008 Feasibility Study	25
6.3 Metallurgical Testwork Review (2009 to 2018)	27
6.4 Processing Technology Options	28
6.5 Product Options	31



6.6	Recommendations.....	32
6.6.1	Resource Estimate	32
6.6.2	Mine Plan.....	32
6.6.3	Aker Phase 1 Feasibility Study	32
6.6.4	Processing Technologies.....	33
6.6.5	Product Options.....	35
6.6.6	Market Study	35
7	MINING STUDIES	36
7.1	Introduction	36
7.2	Mining Study Gaps.....	36
7.2.1	Hydrogeological Model.....	36
7.2.2	Geotechnical Model.....	36
7.2.3	Resource Model.....	36
7.2.4	Ore Reserves.....	37
7.2.5	Mine Optimisation and Pit Designs.....	41
7.2.6	Mine Scheduling	42
7.2.7	Capital Costs	42
7.2.8	Operating Costs	42
7.2.9	Waste Rock Characterisation.....	42
7.2.10	Infrastructure Requirements	43
7.2.11	Other Mining-Related Matters	43
8	EXPLORATION POTENTIAL AND PROPOSED WORK.....	45
8.1	Internal High-Grade Resource Domain Delineation	45
8.2	Extension of Existing Mineralisation.....	47
8.3	Regional Exploration.....	47
8.4	Lewis Calcrete Deposit.....	47
9	RISKS AND OPPORTUNITIES.....	49
9.1	Risks.....	49
9.2	Opportunities	50
9.3	Climate Change-Related Risks and Opportunities with Increased Global Focus on Environment, Social and Governance Factors	51
10	USE OF FUNDS.....	53
10.1	Use of Funds Summary	53
11	REFERENCES	54
12	GLOSSARY	55
13	ABBREVIATIONS AND UNITS OF MEASUREMENT	57

For personal use only



Figures

Figure 1:	Location of the CMP, Western Australia and South Australia	1
Figure 2:	Stylised generic nickel-cobalt laterite profile and preferred process routes.....	9
Figure 3:	Regional geology of the Musgrave Province.....	10
Figure 4:	Simplified outcrop geological map of the Western and Central Musgraves area.....	11
Figure 5:	Simplified geological setting of the Wingellina, Beadell and Claude Hills laterite deposits.....	12
Figure 6:	Simplified geological setting of the Wingellina deposit (section lines correspond to Figure 7).....	14
Figure 7:	Generalised cross-sections through the Wingellina deposit, view looking northwest (section lines correspond to Figure 6)	15
Figure 8:	Claude Hills deposit geology and drillhole locations.....	17
Figure 9:	Lewis calcrete deposit geology	18
Figure 10:	Wingellina 2008 Phase 1 Feasibility Study – indicative site layout	43
Figure 11:	Wingellina Resource outline with high-grade cobalt domains	46
Figure 12:	Drill plan for the Lewis calcrete deposit	48
Figure 13:	Impact of 1.5°C and 2.0°C global warming.....	51

Tables

Table 1:	Mineral Resource estimation for the Wingellina Project.....	III
Table 2:	Ore Reserve estimation for the Wingellina Project	III
Table 3:	Proposed exploration expenditure summary by activity	V
Table 4:	Tenement schedule for the CMP.....	6
Table 5:	Mineral Resource estimation for the Wingellina Project.....	23
Table 6:	Ore Reserve estimation for the Wingellina Project	24
Table 7:	CMP Mineral Resource estimate.....	37
Table 8:	Wingellina nickel-cobalt project Ore Reserve estimate.....	38
Table 9:	Wingellina nickel-cobalt deposit – gap analysis	38
Table 10:	Proposed exploration expenditure summary by activity	53

Appendices

Appendix A	JORC Table 1
------------	--------------



1 Introduction

1.1 Context, Scope and Terms of Reference

CSA Global Pty Ltd (CSA Global), an ERM Group company, was requested by NICO Resources Limited (NICO) to prepare a Technical Assessment Report (“Report”) for use in a prospectus to support the acquisition of the Wingellina Nickel Project (“Wingellina Project” or “Wingellina”), its Claude Hills Nickel Project (“Claude Hills Project” or “Claude Hills”) and Mount Davies Nickel Project (“Mount Davies Project” or “Mount Davies”), collectively, the Central Musgrave Project (“CMP” or the “Project”) – Figure 1 – from Metals X Limited (Metals X).

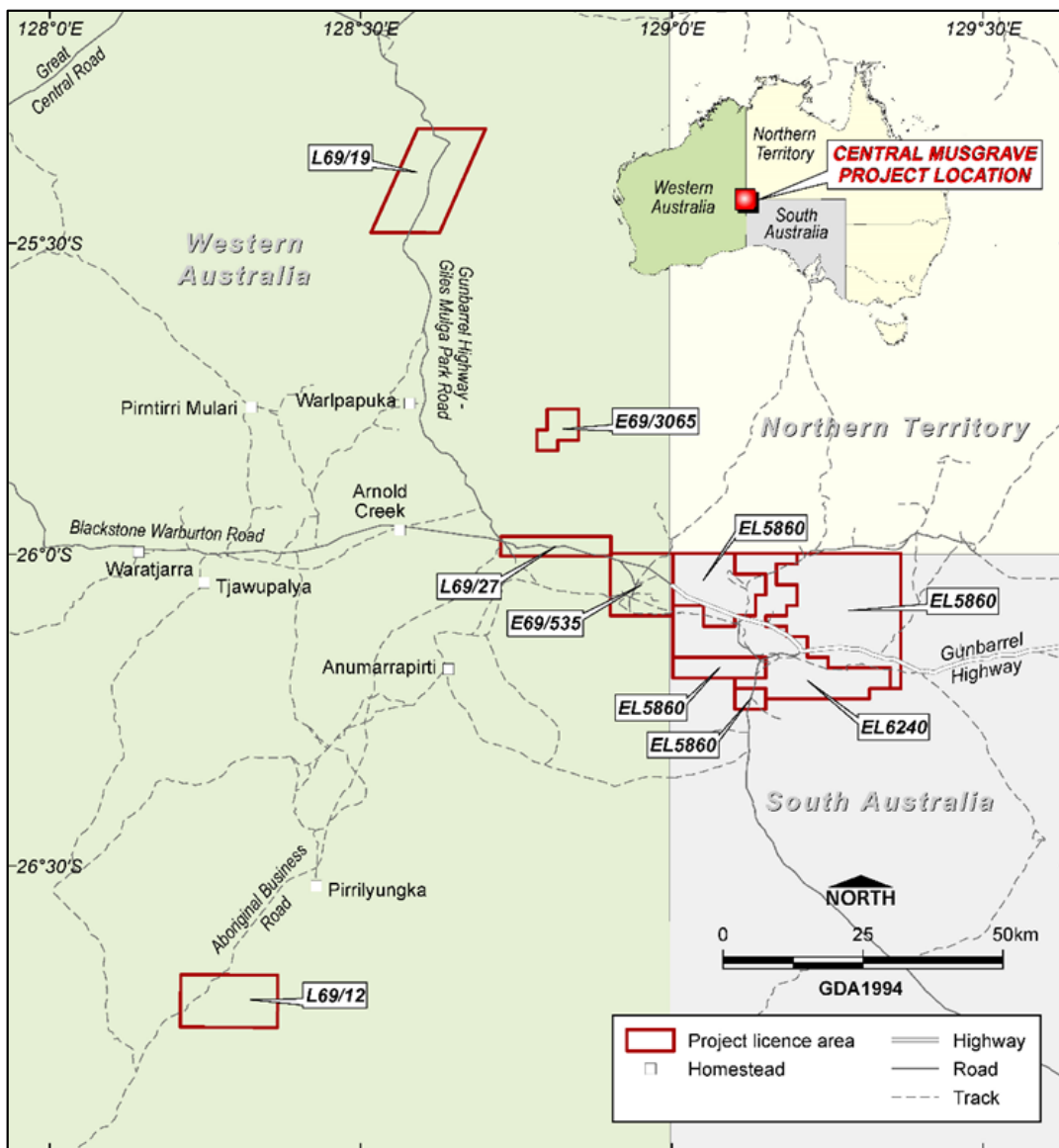

Figure 1: Location of the CMP, Western Australia and South Australia

For personal use only



The CMP comprises two lateritic nickel-cobalt resource areas; Wingellina located within Western Australia, and Claude Hills located within South Australia. NICO intends to undertake an IPO and seek a listing on the Australian Securities Exchange (ASX). This Report is a Technical Assessment Report subject to the Australasian Code for Public Reporting of Technical Assessments and Valuations of Mineral Assets 2015 (“VALMIN¹ Code”).

In preparing this Report, CSA Global:

- Relied on the accuracy and completeness of the data provided to it by NICO, and that NICO made CSA Global aware of all material information in relation to the CMP.
- Relied on NICO’s representation that it will hold adequate security of tenure for exploration and assessment of the CMP to proceed.
- Has independently verified the data used to prepare this Report and concludes that the data provide reasonable grounds for CSA Global’s conclusions reached in this Report.

1.2 Compliance with the VALMIN and JORC Codes

The Report has been prepared in accordance with the VALMIN Code, which is binding upon Members of the Australian Institute of Geoscientists (AIG) and the Australasian Institute of Mining and Metallurgy (AusIMM), the JORC² Code, and the rules and guidelines issued by such bodies as the ASIC and ASX that pertain to Independent Expert Reports.

1.3 Principal Sources of Information and Reliance on Other Experts

CSA Global has based its review of the Project on the information made available to it by NICO, along with technical reports prepared by consultants, government agencies and previous tenements holders, and other relevant published and unpublished data. CSA Global has also relied upon discussions with NICO’s management for the information contained within this assessment. This Report has been based upon information available up to and including 30 August 2021.

CSA Global has endeavoured, by making all reasonable enquiries, to confirm the authenticity, accuracy, and completeness of the technical data upon which this Report is based. Unless otherwise stated, information and data contained in this technical report or used in its preparation have been provided by NICO in the form of documentation.

NICO was provided with a final draft of this Report and requested to identify any material errors or omissions prior to its lodgement.

Descriptions of the mineral tenure (tenure agreements, encumbrances, and environmental liabilities) were provided to CSA Global by NICO or its technical consultants. NICO has warranted to CSA Global that the information provided for preparation of this report correctly represents all material information relevant to the CMP. CSA Global has not reviewed the status of NICO’s tenure agreements for the Project, and has relied on information provided by NICO, and its independent solicitors, about the status of the tenements.

Neither CSA Global, nor the authors of this Report, is qualified to provide comment on any legal issues associated with the CMP. The property descriptions presented in this report are not intended to represent a legal opinion as to the nature and status of the tenure, but to provide a simplified summary to assist the reader and provide context to the Report following the JORC and VALMIN codes.

This Report contains statements attributable to third parties. These statements are made or based upon statements made in previous technical reports that are publicly available from either government departments or the ASX. The authors of these previous reports have not consented to the statements’ use

¹ Australasian Code for Public Reporting of Technical Assessments and Valuations of Mineral Assets (The VALMIN Code), 2015 Edition, prepared by the VALMIN Committee of the Australasian Institute of Mining and Metallurgy and the Australian Institute of Geoscientists. <<http://www.valmin.org>>

² Australasian Code for Reporting of Exploration Results, Mineral Resources and Ore Reserves. The JORC Code, 2012 Edition. Prepared by: The Joint Ore Reserves Committee of The Australasian Institute of Mining and Metallurgy, Australian Institute of Geoscientists and Minerals Council of Australia (JORC). <<http://www.jorc.org>>



in this report, and these statements are included in accordance with ASIC Corporations (Consents to Statements) Instrument 2016/72.

CSA Global's statements and opinions contained in this Report are given in good faith and in the belief that they are not false or misleading. The conclusions are based on the reference date of 30 August 2021 and could alter over time depending on exploration results, mineral prices, and other relevant market factors.

1.4 Prior Association and Independence

Neither CSA Global, nor the authors of this Report, have or have had previously, any material interest in the Wingellina, Claude Hills or Mount Davies projects, the mineral properties in which NICO will have an interest. CSA Global's relationship with NICO is solely one of professional association between a client and an independent consultant.

CSA Global is an independent geological and mining consultancy. This Report is prepared in return for professional fees based upon agreed commercial rates and the payment of these fees is not contingent on the results of this Report.

No associate or employee of CSA Global is, or is intended to be, a director, officer, or other direct employee of NICO. There is no agreement between CSA Global and NICO as to either company providing further work for CSA Global.

CSA Global has in the past completed work for Metals X on various discrete studies, comprising assessment of exploration and resources, nickel and cobalt end product market studies, and advice on potential process options and scoping a potential PFS.

The work completed by CSA Global was not influenced by NICO and reflects its objective critical analysis and professional judgement.

1.5 Authors of the Report

CSA Global, an ERM Group company, is a privately owned, mining industry consulting company headquartered in Perth, Western Australia. CSA Global provides geological, resource, mining, management and corporate consulting services to the international resources sector and has done so for more than 30 years.

This Report has been prepared by a team of consultants sourced principally from CSA Global's Perth, Western Australia office. The individuals who have provided input to this Report have extensive experience in the mining industry and are members in good standing of appropriate professional institutions:

- Coordinating Author – Ms Ivy Chen (Manager Corporate and Principal Consultant with CSA Global in Perth, Western Australia) is responsible for the entire Report
- Contributing Author – Mr Tony Donaghy (Principal Geologist and Nickel Technical Director with CSA Global in Perth, Western Australia) is responsible for the entire Report
- Contributing Author – Mr Mark Laing (Principal Mining Engineer with CSA Global in Perth, Western Australia) is responsible for the entire Report
- Peer Reviewer – Mr Mick Elias (Principal Consultant with CSA Global in Perth, Western Australia) is responsible for the entire Report
- Partner in Charge – Mr Graham Jeffress (Partner in Charge APAC and Principal Geologist with CSA Global in Perth, Western Australia) is responsible for the entire Report.

Ms Ivy Chen is a corporate governance specialist, with over 30 years' experience in mining and resource estimation. Ivy served as the national geology and mining adviser for the ASIC from 2009 to 2015. Ivy's experience in the mining industry in Australia and China as an operations and consulting resource geologist includes open pit and underground mines for gold, manganese and chromite, and as a consulting geologist, she has conducted mineral project evaluation, strategy development and implementation, through to senior corporate management roles. Recent projects completed include listings and other commercial transactions



on the Australian, Singapore, Hong Kong, and UK stock exchanges. Ivy is a company director and a member of the VALMIN Committee. Ivy manages CSA Global's Corporate Team and coordinates and participates in CSA Global's activities providing expert technical reviews, valuations, and independent reporting services to groups desiring an improved understanding of the value, risks and opportunities associated with mineral investment opportunities.

Mr Tony Donaghy is a Principal Consultant and Technical Director Nickel with CSA Global in Perth, Western Australia. Tony is an internationally recognised expert in the global search for nickel, copper, cobalt and platinum group elements (PGEs), and a skilled exploration geologist who is familiar with most geological environments and a broad variety of mineral commodities. He has more than 25 years' experience covering all continents and all aspects of the industry – from leading continental-scale grassroots targeting exercises, through greenfields and brownfields exploration project design and execution, mining, property evaluation and due diligence, to board level strategy development and guidance. Tony is a Registered Professional Geoscientist with the Association of Professional Geoscientists of Ontario, an RPO and has sufficient experience that is relevant to the Technical Assessment of the Mineral Assets under consideration, the style of mineralisation and types of deposit under consideration and to the activity being undertaken to qualify as a Practitioner as defined in the 2015 Edition of the "Australasian Code for the public reporting of technical assessments and Valuations of Mineral Assets", and as a Competent Person as defined in the 2012 Edition of the "Australasian Code for Reporting of Exploration Results, Mineral Resources and Ore Reserves".

Mr Mark Laing is a mining engineer with more than 35 years' experience, in both open pit and underground mining. Mark holds First Class Mine Manager tickets in Western Australia, Queensland, and Tasmania. He has specialised skills in open pit and underground mine design, pit and waste dump optimisation, mine scheduling, Ore Reserve reporting, project evaluation, due diligence and feasibility studies. Mark's extensive operational experience, built over 30 years of site-based work for a variety of mining companies operating throughout Australia and overseas, has provided both practical as well as management and corporate experience. He has strong expertise in precious (gold, silver), base metals (nickel, manganese, zinc, lead), and coal.

Mr Mick Elias is a Principal Consultant with CSA Global in Perth, Western Australia. Mick specialises in all aspects of the nickel resources industry, both in sulphides and laterites. He has 40 years' experience in mine geology, project generation and evaluation, exploration planning and management and development studies, much of it in senior management positions during a 21-year career with WMC Resources involving both nickel and gold. During this time, and since joining CSA Global in 2001, Mick has seen and investigated most of the substantial nickel deposits known worldwide. He has published a number of professional papers in the field of lateritic nickel and presented at numerous conferences.

Mr Graham Jeffress is a geologist with over 30 years' experience in exploration geology and management in Australia, Papua New Guinea, and Indonesia. Graham is Partner APAC and Principal Geologist with CSA Global in Perth and manages the APAC region for CSA Global. Graham has worked in exploration (ranging from grassroots reconnaissance through to brownfields, near-mine, and resource definition), project evaluation and mining in a variety of geological terrains, commodities, and mineralisation styles within Australia and internationally. He is competent in multidisciplinary exploration, and proficient at undertaking prospect evaluation and all phases of exploration. Graham has completed numerous independent technical reports (IGR, CPR, QPR) and valuations of mineral assets. Graham was a Federal Councillor of the AIG for 11 years and joined the Joint Ore Reserves Committee in 2014.

1.6 Declarations

This Report has been prepared by CSA Global at the request of, and for the sole benefit of NICO. Its purpose is to provide an independent Technical Assessment Report of NICO's CMP.

The Report is to be included in its entirety or in summary form within a prospectus to be prepared by NICO in connection with an IPO. It is not intended to serve any purpose beyond that stated and should not be relied upon for any other purpose.



The statements and opinions contained in this Report are given in good faith and in the belief that they are not false or misleading. The conclusions are based on the reference date of 30th August 2021 and could alter over time depending on exploration results, mineral prices, and other relevant market factors.

1.6.1 *Competent Person's Statement*

The information in this Report that relates to Exploration Targets, Exploration Results, and *in situ* Mineral Resources for the Project is based on information reviewed by Mr Jake (Jacob) Russell from Metals X, who was previously an employee of Metals X, and is a members of the AIG, and has sufficient experience, which is relevant to the style of mineralisation and type of deposit under consideration, and to the activity he is undertaking, to qualify as a Competent Persons in terms of the "Australasian Code for Reporting of Exploration Results, Mineral Resources and Ore Reserves" (JORC Code, 2012 Edition).

The Exploration Targets, Exploration Results and Mineral Resources information has been reviewed by Mr Tony Donaghy is a Principal Consultant and Technical Director Nickel with CSA Global in Perth, Western Australia. Mr Donaghy takes overall responsibility for the Report as Competent Person. Mr Donaghy is a Registered Professional Geoscientist with the Association of Professional Geoscientists of Ontario, an RPO and has sufficient experience that is relevant to the Technical Assessment of the Mineral Assets under consideration, the style of mineralisation and types of deposit under consideration and to the activity being undertaken to qualify as a Practitioner as defined in the 2015 Edition of the "Australasian Code for the public reporting of technical assessments and Valuations of Mineral Assets", and as a Competent Person as defined in the 2012 Edition of the "Australasian Code for Reporting of Exploration Results, Mineral Resources and Ore Reserves" The Competent Person, Mr Donaghy has reviewed the Mineral Resources statement and given permission for the publication of this information in the form and context within which it appears in this report.

The information in this Report that relates to Ore Reserves is based on information compiled by Mr Michael Poepjes, who was a previous employee of Metals X in 2016, and a Member of the AusIMM at the time. This information has been reviewed by Mr Mark Laing, an employee of CSA Global. Mr Laing takes overall responsibility for the Report as a Competent Person. Mr Laing is a Member of the AusIMM and has sufficient experience, which is relevant to the style of mineralisation and type of deposit under consideration, and to the activity he is undertaking, to qualify as a Competent Person in terms of the JORC Code (2012 Edition). The Competent Person, Mr Laing has reviewed the Ore Reserve statement and given permission for the publication of this information in the form and context within which it appears in this report.

1.6.2 *No Site Inspection*

The CMP is at an advanced exploration stage, with limited site infrastructure and little outcropping geology pertinent to the Project assessment process. No site visit was made to the CMP in connection with this Report, as the authors have sufficient prior knowledge of the area, the mineralisation type, and the experience to assess the Project.

In CSA Global's professional judgement, given the stage of the CMP, an additional site visit is unlikely to materially improve its understanding of the Project.



2 Project Tenure and Location

Tenement details are listed in Table 4. CSA Global is not qualified to give opinions on legal matters of tenement status or liabilities. CSA Global relies on the legal opinion of Blackwall legal LLP, Level 26, 140 St Georges Terrace, Perth, Western Australia, 6000. NICO has advised CSA Global that the due diligence on matters in respect of the Project's tenure is covered by an Independent Solicitor's Report prepared by Blackwall Legal that appears in the Prospectus.

NICO has a 100% interest in the CMP (Figure 1, Table 4) through wholly-owned subsidiaries Hinckley Range Pty Ltd in Western Australia and Austral Nickel Pty Ltd in South Australia. The CMP comprises four granted Exploration Licences (E69/0535 and E69/3065 in Western Australia; EL5860 and EL6240 in South Australia) and three granted Miscellaneous Licences (L69/0012, L69/0019 and L69/0027 in Western Australia). The seven tenements combined cover a total area of 1,468.6 km².

Table 4: Tenement schedule for the CMP

Tenement ID	State	Status	Holders	Application	Grant	Expiry	Current area (km ²)	Tenement type
E69/0535	WA	Granted	Hinckley Range Pty Ltd	5 Aug 1991	23 Dec 1993	22 Dec 2021	110.78	Exploration Licence
E69/3065	WA	Granted	Hinckley Range Pty Ltd	24 May 2012	5 Jun 2013	4 Jun 2023	37.01	Exploration Licence
L69/0012	WA	Granted	Hinckley Range Pty Ltd	23 Oct 2007	26 Feb 2009	25 Feb 2030	144.93	Miscellaneous Licence
L69/0019	WA	Granted	Hinckley Range Pty Ltd	05 Dec 2012	29 Aug 2013	28 Aug 2034	203.93	Miscellaneous Licence
L69/0027	WA	Granted	Hinckley Range Pty Ltd	12 Apr 2017	13 Jun 2018	12 Jun 2039	61.95	Miscellaneous Licence
EL5860	SA	Granted	Austral Nickel Pty Ltd	18 Mar 2016	20 Jun 2016	19 Jun 2021	572	Exploration Licence
EL6240	SA	Granted	Austral Nickel Pty Ltd	19 Jun 2017	24 Sep 2017	23 Sep 2021	338	Exploration Licence
Total							1,468.6	

The Application for an Extension of Term to 22 December 2022 for E69/0535 is currently in process. An Application for an Extension of Term for EL5860 was submitted in April 2021.

The CMP is located along the Great Central Road immediately to the southwest, south and southeast of Surveyor General's Corner, the border junction between Western Australia, Northern Territory and South Australia. The north-eastern corner of Exploration Licence E69/0535 and the north-western corner of EL5860 are coincident with Surveyor General's Corner.

Exploration Licence E69/0535 encloses the small community of Wingellina (Irrunytju), which serves inhabitants of Aboriginal Reserve A17614. The Wingellina townsite grew at the location of the 1960s International Nickel Company (INCO) exploration camp, due to the availability of potable bore water.

Permits from the Ngaanyatjarra Land Council are required for all personnel entering the area on the Western Australia side of the border.

Exploration licences EL5860 and EL6240 are centred on the Aboriginal communities of Kalka and Pipalyatjara within Anangu Pitjantjatjara Yankunytjatjara (APY) Lands in South Australia. These communities serve the inhabitants of the extreme northwest of the APY Land. Permits from the appropriate Land Councils are required for all personnel working in the region. The tenement lies within the recently declared Kalka-Pipalyatjara Indigenous Protected Area.

The area can be accessed from Warburton or Giles, both of which are on the Great Central Road connecting Laverton in Western Australia to Uluru in the Northern Territory. Alternative access can be gained from the

NICO RESOURCES LIMITED
TECHNICAL ASSESSMENT REPORT



east via the Giles-Mulga Park Road in South Australia (the Gunbarrel Highway). Travel within the Project area is via a few major and minor unsealed roads and rough bush tracks.

All the communities have airstrips suitable for small-scale charter flight and Royal Flying Doctor Service aircraft.

For personal use only



3 Mineralisation and Geology

3.1 Mineralisation Model

Nickel-cobalt laterite processes, and mineralisation in the CMP, have been reviewed extensively by Marsh et al. (2013) and Metals X (2021). The following is a synopsis of their work.

Nickel-cobalt laterites are supergene deposits formed from the pervasive chemical and mechanical weathering of olivine-rich ultramafic rocks. Unweathered olivine-rich ultramafic rocks can contain as much as 0.3% Ni, the nickel and cobalt residing in the olivine mineral lattice. These rocks occur within komatiites and intrusive complexes as peridotites and dunites. The extreme weathering breaks down all susceptible primary minerals and releases the nickel and cobalt into solution. The released chemical components are dispersed in groundwater or become incorporated into altered or new minerals that are stable in the weathering environment.

Nickel-cobalt laterites are classified based on their mineralogical characteristics. The factors involved in the development of the weathering profile are key to the concentration of nickel and cobalt into certain minerals. The mineralogical characteristics subdivide the nickel-bearing ores into subtypes, which have critical differences in their profile development, structure and chemistry that affect extraction and processing techniques. Typically, laterite zones represent a condensing of the original profile, occupying a smaller volume than the original rock that has weathered to form the laterite, with the material lost having been leached away by groundwater resulting in residual concentration of the elements that are left.

In basic terms, two different ore types are the most commonly developed: limonite types and silicate types:

- Limonite-type laterites (or oxide type) are highly enriched in iron due to very strong leaching of magnesium and silica. They consist largely of goethite and contain 1–2% Ni incorporated in goethite. The absence of a limonite zone in a mineral deposit is usually due to erosion.
- Silicate type (or saprolite type) nickel ore occurs beneath the limonite zone. It contains generally 1.5–2.5% Ni and consists largely of weathered silicate minerals or serpentine in which nickel is incorporated. In pockets and fissures of the saprolite zone green garnierite can be present in minor quantities, but with high nickel contents (mostly 20–40%). It is bound in newly formed phyllosilicate minerals. All the nickel in the silicate zone is leached downwards from the overlying goethite zone.

All mineralogical types of ore may be present in a single nickel-cobalt laterite deposit (Figure 2). The relative proportions in a single laterite profile between limonite and silicate depend on several interplaying factors such as water table depth, climate, regolith chemistry/rates of chemical weathering, drainage, and tectonics. The prevalence of any portion of laterite type in the overall profile for an individual deposit will have significant ramifications on the optimum process route required to extract nickel (and other elements) from that profile type.

Laterite deposits in the arid environment of Western Australia are generally of the limonite-type with condensed silicate zones on the bedrock interface at the base of oxidation.

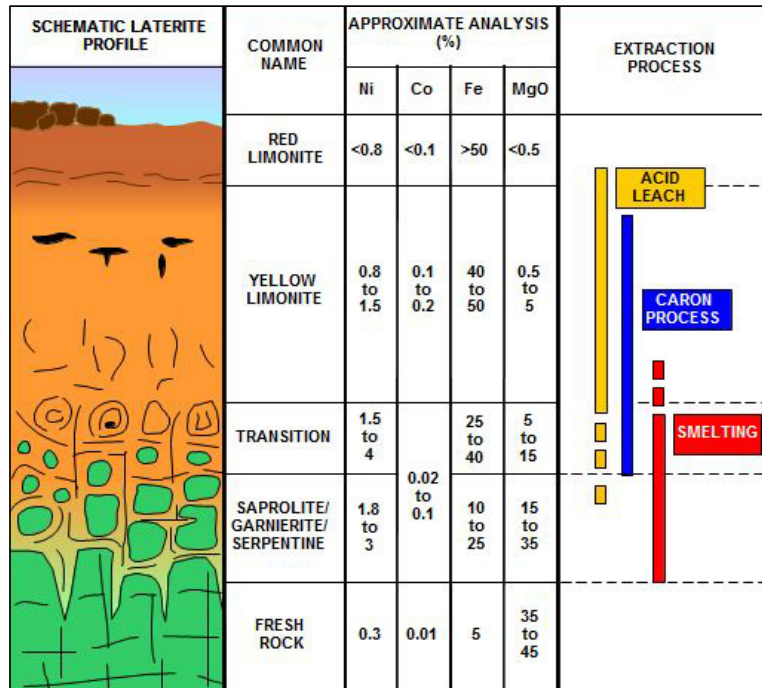

Figure 2: Stylised generic nickel-cobalt laterite profile and preferred process routes

3.2 Geology

3.2.1 Regional Geology

The geology of the Musgrave Province has been extensively reviewed by Seat et al. (2007), Seat et al. (2009), Seat et al. (2011), Godel et al. (2011), Joly et al. (2014), Seubert (2017), Walsh (2017), Quentin de Gromard et al. (2017), and Grguric et al. (2018). The following is a synopsis of their work.

The Musgrave Province is a Mesoproterozoic belt covering an area up to 800 km long and 350 km wide that straddles the borders between the Northern Territory, Western Australia, and South Australia. It lies at the convergence of Australia's main Proterozoic structural trends that reflect the amalgamation of the North, West, and South Australian cratons (Figure 3).

For personal use only

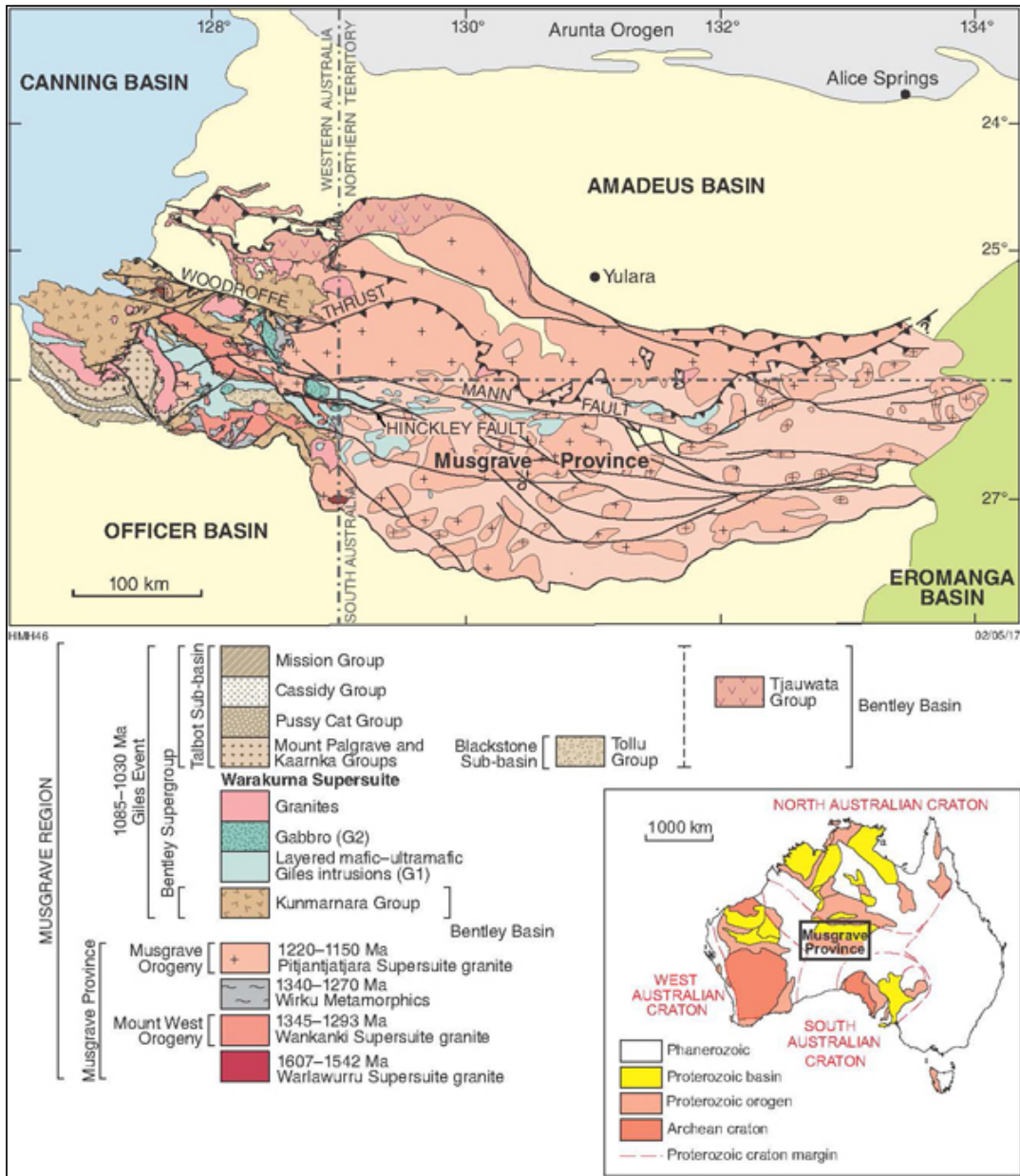

Figure 3: Regional geology of the Musgrave Province

Source: <http://dmp.wa.gov.au/Geological-Survey/West-Musgrave-Province-21418.aspx>

Exposures are largely confined to the prominent ranges (Figure 4) separated by alluvium/colluvium outwash plains and aeolian dunes. Regional magnetic and gravity surveys, and reconnaissance seismic traverses indicate the boundaries with the Neoproterozoic and Palaeozoic basins to the north and south are largely tectonic.

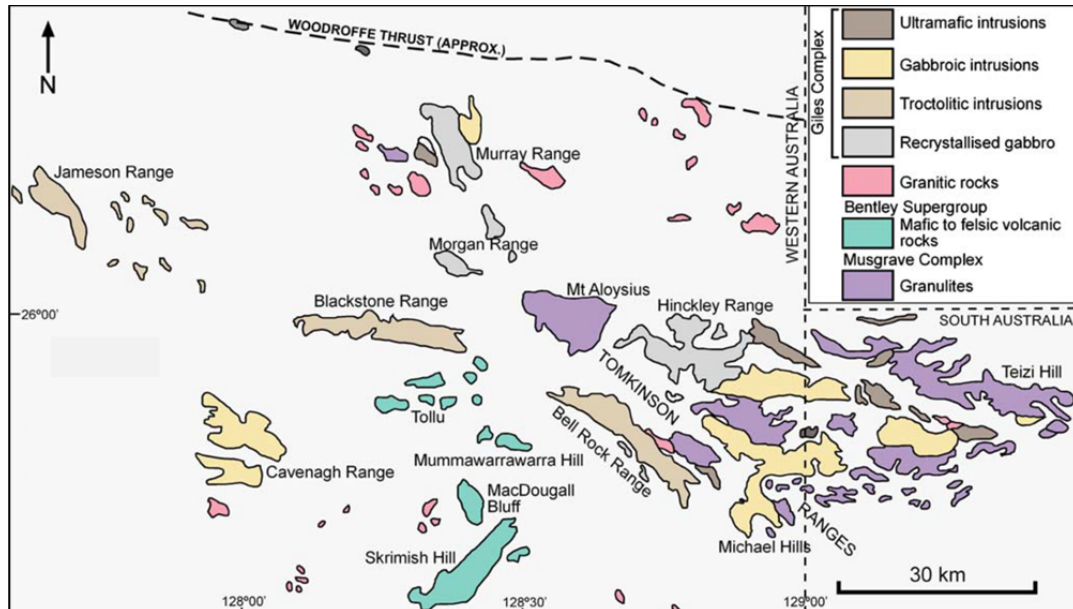

Figure 4: Simplified outcrop geological map of the Western and Central Musgraves area
Source: After Seat et al. (2007)

The Proterozoic basement geology of the Musgrave Province is composed of seven main rock groups:

- c. 1600–1300 Ma well-layered, amphibolite to granulite facies, felsic and mafic orthogneiss and quartzofeldspathic, pelitic and calc-silicate paragneiss basement rocks. Metamorphism during the c. 1200–1170 Ma Musgrave Orogeny caused anhydrous melting, producing migmatites, granitic intrusions, and pegmatites.
- c. 1200 Ma highly metamorphosed suite of metagranites.
- c. 1080 Ma variably metamorphosed granite.
- c. 1085–1030 Ma variably metamorphosed intrusive rocks of the mafic-ultramafic Giles Complex.
- c. 1080–1050 Ma surficial volcanics, both mafic (Mummawarrawarra Basalt) and andesitic to rhyolitic (Tollu, Smoke Hill Volcanics), including the c. 1080 Ma Bentley Supergroup volcanics and sediments.
- c. 1080–1050 Ma large caldera type granite intrusive complexes (Palgrave, Skrimish Hill, Smoke Hill).
- c. 1050 Ma intrusive suite of typically un-metamorphosed granites.

The Musgrave Province is traversed by a series of east-west trending major shear zones, which impart a prominent east-west structural “grain” to the country. The main shear zones are the Hinckley-Scarface, Mann-Ferdinand, Davenport and Woodroffe systems, and these may have originally developed during the c. 1200–1170 Ma Musgravian Orogeny. Reactivation during the c. 550 Ma Petermann Orogeny resulted in the development of high strain mylonite and ultra-mylonite zones along these major pre-existing structures.

The Giles Complex is the name given to a regionally extensive complex of multiple ultramafic, mafic and anorthositic intrusions with a combined surface area of at least 1,200 km². The Complex comprises a series of stacked sills and dykes that were intruded at successively shallower crustal levels. Intrusions north and east of the Hinckley Fault were emplaced at approximately 20 km depth within the crust and had the most primitive, least evolved parental magmas. The Blackstone Range Gabbro intruded along the unconformity between the Bentley Supergroup and basement granulites and has intruded coeval volcanic units in the Tollu Group, implying emplacement at very shallow crustal levels. The Bell Rock Range and Michael Hills intrusions are interpreted to have been emplaced at intermediate depths of 10–12 km. The intrusive rocks represent the most extensive mafic igneous activity recognised in exposed deep levels of the continental crust in Australia.

For personal use only



The rocks of the Giles Complex exhibit considerable compositional variation, ranging from olivine accumulates (dunites) through to anorthosite, with rocks of noritic composition also common. The higher-level intrusions are generally more gabbroic and formed from more evolved or fractionated magmas. The individual complexes vary in character, particularly regarding the amount of constituent ultramafic rock, with some complexes containing almost none. The intrusions are interpreted to be genetically related to each other, being produced by crystal fractionation processes from a common parental magma.

The Giles Complex hosts regionally significant nickel-copper-PGE sulphide mineralisation at Nebo-Babel and Succoth in the West Musgraves of Western Australia, currently being investigated for potential mining by OZ Minerals Ltd.

Seven distinct intrusive episodes of basic dykes and sills, mainly gabbros and dolerites were emplaced post-Giles; these include the Alcurra and Amata Dyke swarms. Two of the earlier mafic dyke suites intruded while the Giles Complex was still cooling resulting in these dykes experiencing contact metamorphism upon intrusion. The majority of the mafic dykes pre-date movement on the Woodroffe Thrust. However, small un-metamorphosed dolerite dykes and sills have intruded the Woodroffe Thrust mylonite zone. These dykes are potentially younger than mid-Cambrian.

The Musgrave Province is flanked by several Proterozoic to Palaeozoic sedimentary basins, whose sedimentary history is linked to tectonic events in the Musgrave Province post-1080 Ma. These include the Proterozoic Amadeus and Officer basins.

Laterite mineralisation is developed on portions of the ultramafic sections of the Giles Complex intrusive units, including the Wingellina, Beadell and Claude Hills deposits (Figure 5).

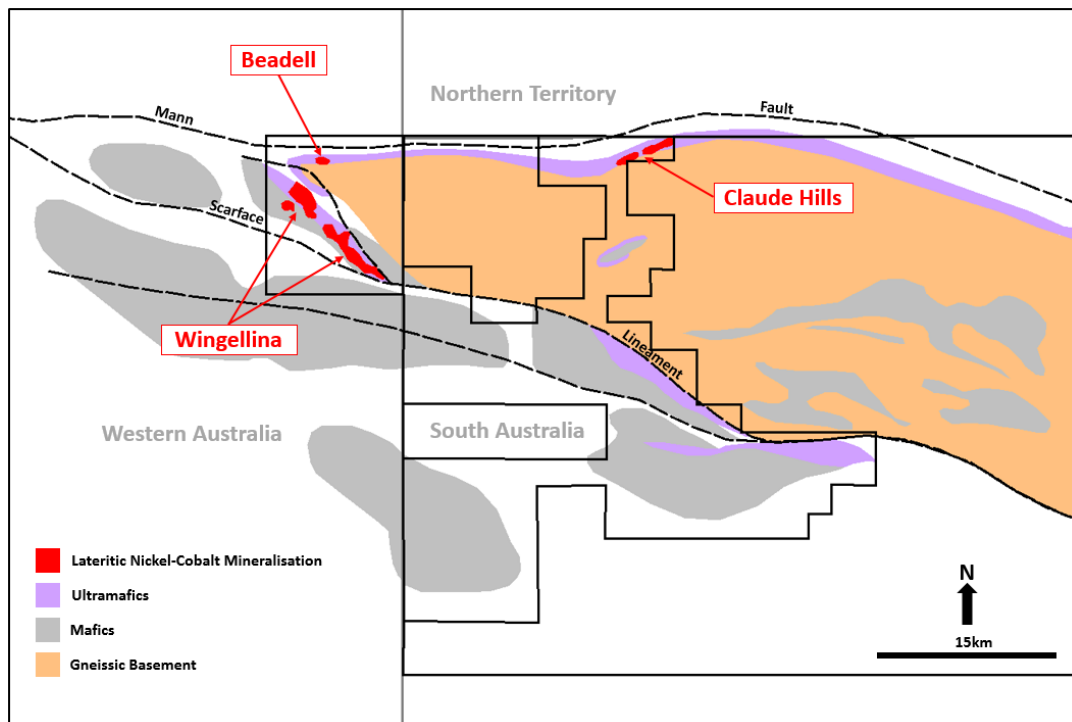

Figure 5: Simplified geological setting of the Wingellina, Beadell and Claude Hills laterite deposits
Source: Metals X (2019)



3.2.2 Local Geology and Mineralisation – Wingellina

The local geology and mineralisation in the CMP have been reviewed extensively by Metals X (2018a, 2021). The following is a synopsis of those reports.

The Wingellina nickel-cobalt oxide deposits occur in deeply weathered ultramafic (olivine-rich) members of the Hinckley Range Gabbro, a component of the Giles Complex (Figure 4). The Wingellina deposits lie within the Wingellina Hills, a northwest-trending mafic-ultramafic set of ridges and valleys hosting gabbros, pyroxenites and dunites.

Layering in the intrusions was caused by fractionation and crystal settling within multiple successive magma injections. At Wingellina, this resulted in the formation of a series of ultramafic units overlain by thin pyroxenites and mafic to leucocratic gabbro. Detailed drill core logging has shown that the rhythmic layering of the differentiated mafic-ultramafic sequence is present on a centimetre to 10 m scale, and compositional variation (both chemical and mineralogical) in the parent rock influences the composition of the weathered product.

Steeply southwest dipping (75–85°) shear zones occur parallel to the length of the central part of the Wingellina Hills and affect the ultramafic units and the margins of most gabbros seen in outcrop. Shearing varies in intensity from strong to mylonitic, and has strongly influenced weathering depth, leaching, and limonite formation. East-west, sinistral, brittle cross-structures are also present across the sequence, and are seen to offset the geology in places.

The Wingellina Nickel Deposit is classified as a nickeliferous limonite resource with high iron (as hydrated oxides) and low magnesium oxide, with the higher grades of nickel and cobalt mineralisation being associated with manganese-rich pods and layers that occur in the upper parts of the mineralised profiles. The weathering of the feldspathic components of the intervening gabbro and minor pyroxenite units are major contributors to the relatively high aluminium composition of the mineralisation.

The Wingellina nickel-cobalt oxide mineralisation comprises two main zones which contain several semi-linear northwesterly striking sub-zones of limonitic (iron-rich) and lesser saprolitic (clay-rich) styles of laterite mineralisation.

A separate small deposit, the Beadell Zone to the north of the main deposits at Wingellina, strikes in an east-west direction parallel to and near the Mann Fault (Figure 6). The intrusion hosting the Beadell deposit is inferred to dip steeply to the north. The Beadell deposit does not form part of the Mineral Resource estimate for the Wingellina deposit.

The lateritic nickel deposits have an aggregate strike length (northwesterly) of about 8.5 km and an average width across strike of about 1 km. They cover a combined area of about 1,700 ha. An approximate width for individual oxidised ultramafic units is about 80 m, and their surface expressions in the form of surficial haematitic accretions and associated magnesite nodules can be traced over strike distances of several kilometres.

The nickel mineralisation was produced by deep weathering, facilitated by shearing, of olivine-rich ultramafic units in the Wingellina Hills near the northern contact of the Hinckley Range Gabbro. Olivine crystals within the ultramafic units originally contained background values of about 0.15% to 0.3% Ni. The almost complete removal of magnesium oxide and silica by downward percolating groundwaters during weathering resulted in extreme volume reductions and consequently significant upgrading of Fe₂O₃, Al₂O₃ and the metal elements nickel and cobalt in the weathered profile. The ultramafic units are deeply weathered into asymmetric trough-like shapes that are up to 250 m deep in places. The geological contacts between the completely weathered ultramafic units and the intervening gabbroidal units are transitional (Figure 7).

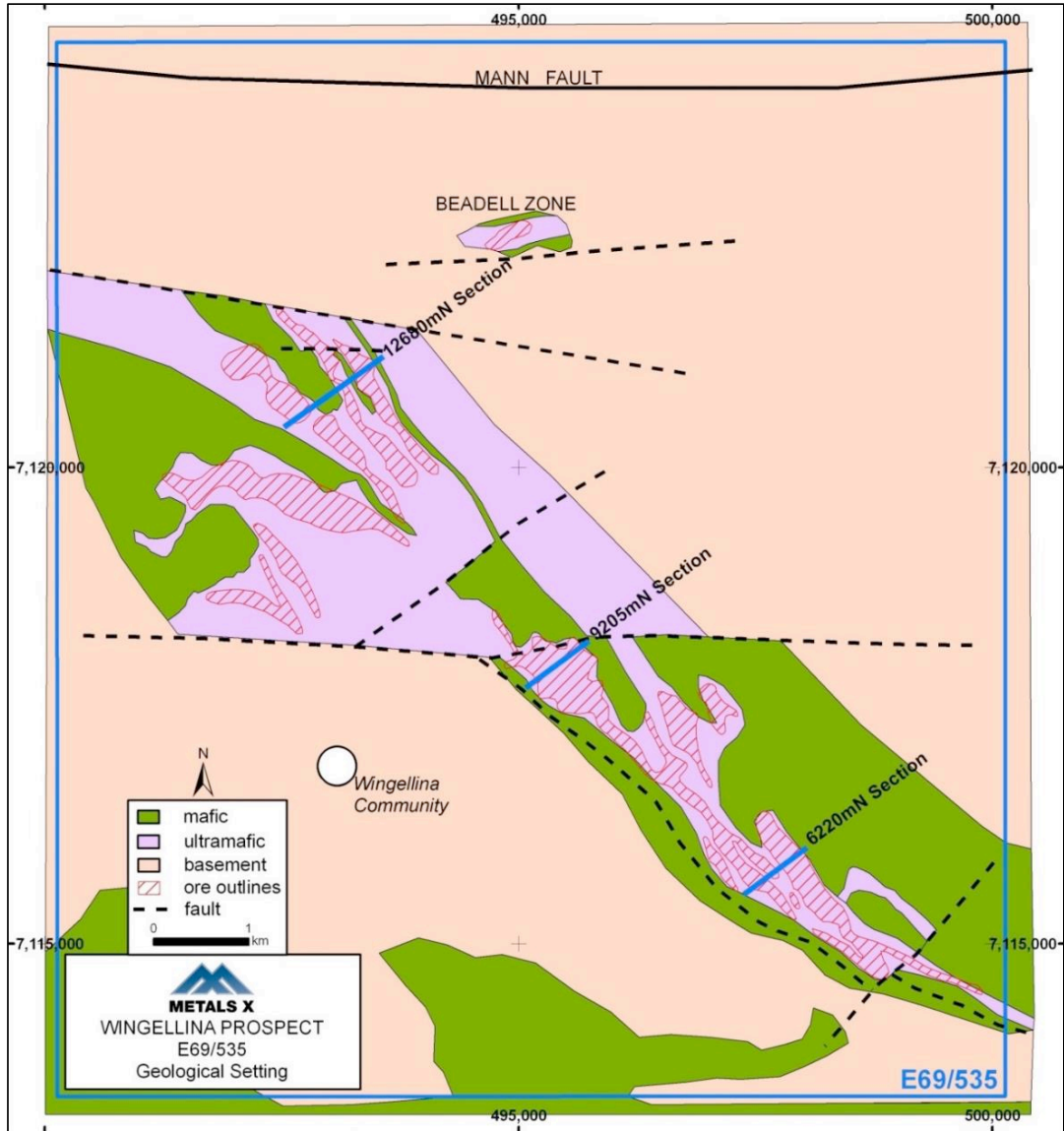

Figure 6: Simplified geological setting of the Wingellina deposit (section lines correspond to Figure 7)
Source: Metals X (2019)

For personal use only

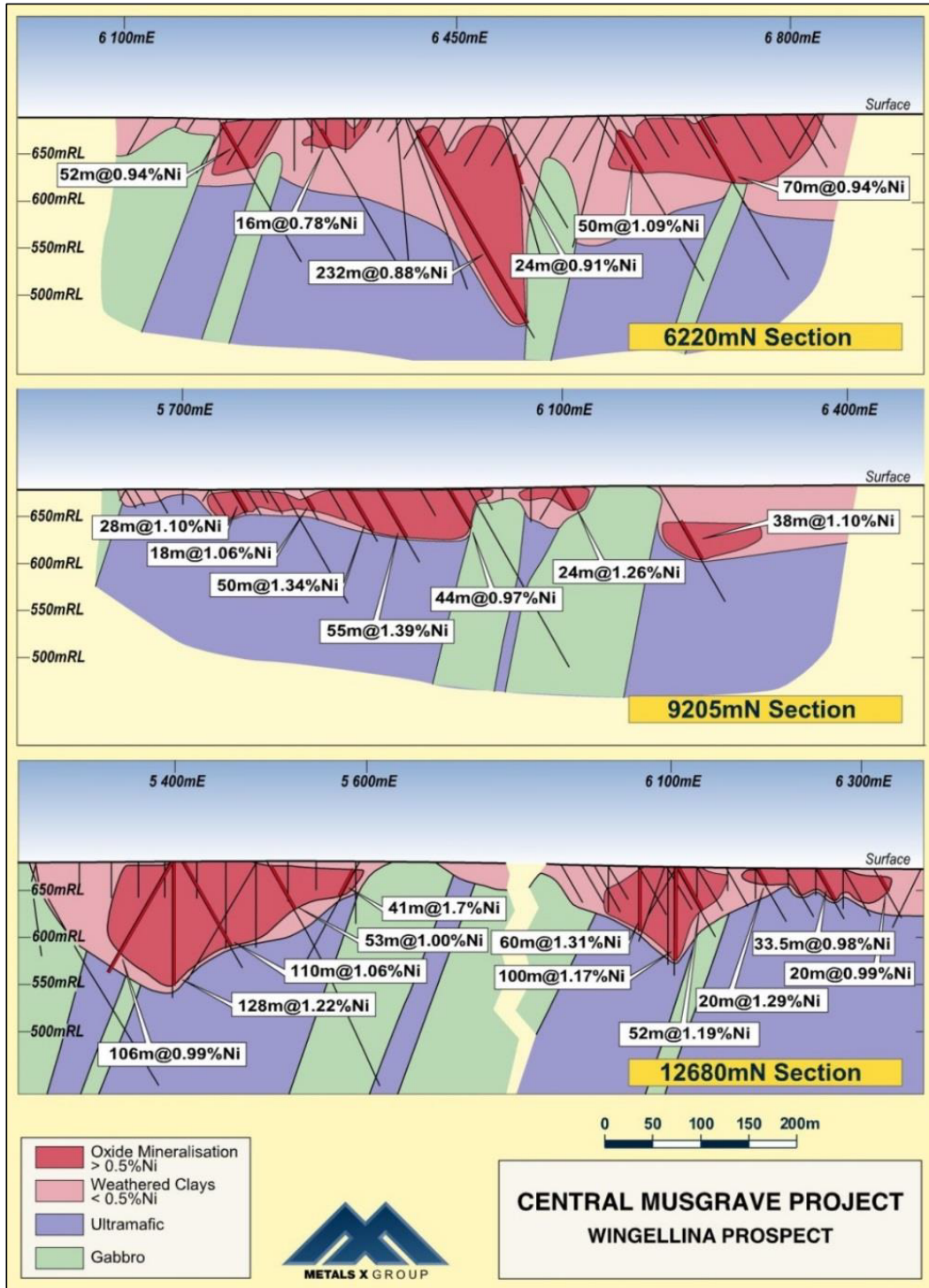

Figure 7: Generalised cross-sections through the Wingellina deposit, view looking northwest (section lines correspond to Figure 6)
Source: Metals X (2019)



The sheared nickel-rich deposits are bounded by hills of resistant noritic gabbros with minor pyroxenites, which have protected the soft laterite from later erosion. The basal ultramafic unit on the northeast contact with the basement gneisses is up to 600 m thick but does not appear to have been deeply sheared or lateritised and contains no nickel oxide mineralisation.

The intensity of weathering decreases with depth, and the removal of the soluble components becomes less complete. This leads to the development of more saprolitic ores toward the base of the deposit, which contain smectitic clays, serpentine, kaolin, and magnesite.

Proximal to the contacts between the ultramafic and the more gabbroic units, the breakdown of plagioclase from the gabbro results in the formation of hydrated aluminosilicates (clayey minerals) that bind some of the magnesium liberated from the weathering of olivines in transitional saprolite zones. Smectite saprolite and nontronite clays and veinlets of magnesite mark the transition into adjacent mafic units.

Manganese is known to be highly mobile in the weathering environment, and irregular pods and layers of manganese oxide, enriched in nickel but especially in cobalt, have formed within the mineralised zones. The distribution of the higher-grade cobalt zones is constrained by their association with high-grade nickel mineralisation within relatively shallow upper parts of the deposit. The high-grade mineralised zones show strong continuity over several hundred metres of strike.

3.2.3 Local Geology and Mineralisation – Claude Hills

The local geology and mineralisation in the CMP have been reviewed extensively by Metals X (2018b, 2019). The following is a synopsis of those reports.

The Claude Hills nickel oxide deposits occur in deeply weathered ultramafic members of the Giles Complex, which has intruded gneisses of the Musgrave Province. The Claude Hills comprise a sequence of pyroxenites and lesser dunites, with minor gabbros, striking east-northeast and facing upward to the south. The sequence is different from that seen at Wingellina, and the Claude Hills belt is now thought to be a separate intrusion. It contains a larger proportion of pyroxenite and a smaller percentage of gabbroic rocks. This means the parent rocks to the Claude Hills laterites are much lower in aluminium than the Wingellina belt, and the resultant nickel-bearing laterites are commensurately lower in Al_2O_3 . The lateritic profile contains a high proportion of ferruginous silcrete layers.

To the north, the sequence is truncated by the Mann Fault, which strikes along the northern boundary of the Exploration Licence. A series of north-northwest-trending brittle (?) dextral faults are also seen to offset the geology in several places.

Layering in the intrusions was caused by crystal fractionation and settling within individual melts of multiple magma injections. The basal dunitic part of the sequence does not outcrop, and it may have been removed by movement along the Mann Fault.

Nickeliferous laterite is restricted to a layered mafic-ultramafic intrusion with substantial thicknesses of dunite and/or peridotite ultramafic. The nickel oxide mineralisation comprises three parallel zones of limonitic and saprolitic styles of laterite mineralisation (Figure 8). The exact relationship between these zones is yet uncertain and further drilling is required to resolve the association. These zones strike east-northeast over approximately 5.5 km. The widths of individual mineralised zones occasionally exceed 300 m, with depths greater than 50 m also observed.

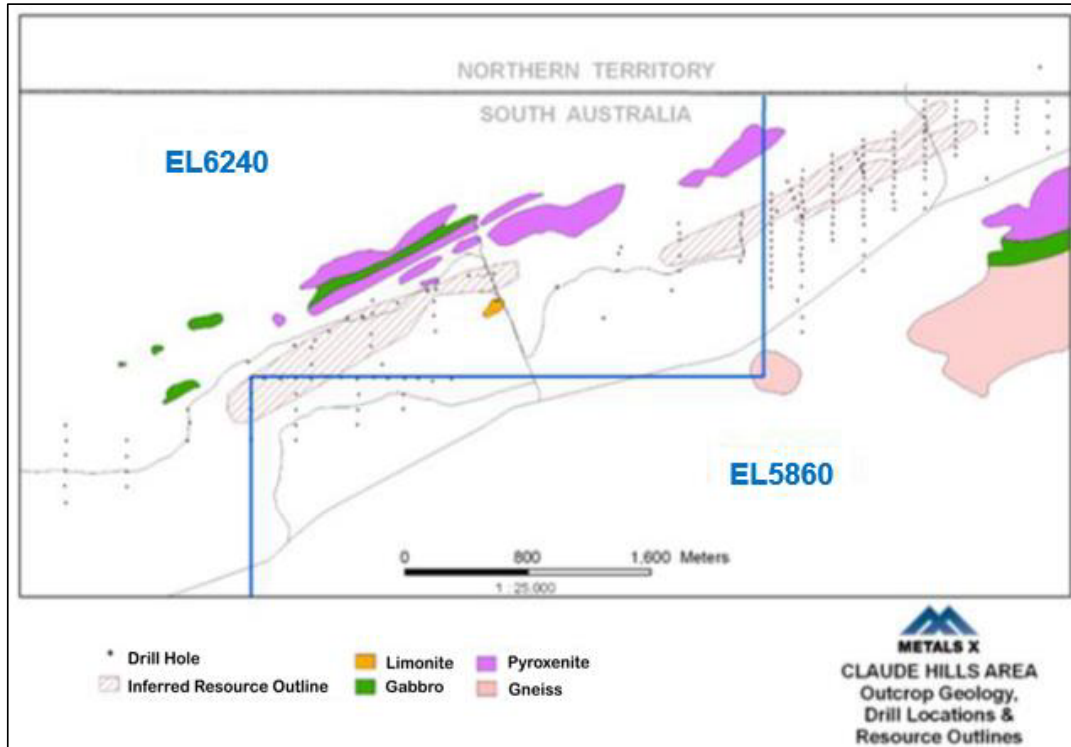

Figure 8: Claude Hills deposit geology and drillhole locations
Source: Metals X (2019)

Deep weathering of olivine-rich ultramafic units has resulted in the concentration of nickel mineralisation. The olivines in the ultramafic units have background values of approximately 0.15% to 0.30% Ni. The almost complete removal of magnesium oxide and silica to groundwaters during the weathering of olivines in the ultramafic units resulted in extreme volume reductions and consequent significant upgrading of other rock-forming oxides (Fe_2O_3 , Al_2O_3) and metal element concentrations in the weathered profile. The ultramafic units are weathered into asymmetric trough-like formations that are up to about 100 m deep in places. Weathering has not been as intense, deep or widespread in the Claude Hills dunites as at Wingellina, and relatively fresh dunite was intersected at shallow depths in some marginal areas. Silica dissolved from the olivines during weathering has accumulated into more defined silcrete layers in the laterite profile at Claude Hills than that seen at Wingellina.

Manganese is known to be highly mobile in the weathering environment, and irregular pods and layers of manganese oxide, enriched especially in cobalt, have formed within the mineralised zones. This is not as pronounced as at Wingellina. The distribution of these zones is poorly defined.

The deposits at Claude Hills are characterised by the presence of barren (yet to be conclusively confirmed by sampling) secondary silica layers.

In general, the deposits at Claude Hills can be classified as nickeliferous laterite with high iron (as hydroxides) and low magnesium and aluminium oxides, with the main source of cobalt mineralisation being associated with manganese-rich pods and layers that occur in the upper parts of the mineralised profiles.

3.2.4 Local Geology and Mineralisation – Lewis Calcrete

The local geology and mineralisation in the Lewis Calcrete have been reviewed extensively by Metals X (2020). The following is a synopsis of that report.



The tenement is entirely underlain by basement granites and gneisses. The basement rocks are overlain by colluvium and sand dune deposits. The tenement encompasses an assumed small Tertiary-Recent palaeovalley that has developed locally. The palaeovalley contains relatively thin deposits of calcrete (Figure 9).

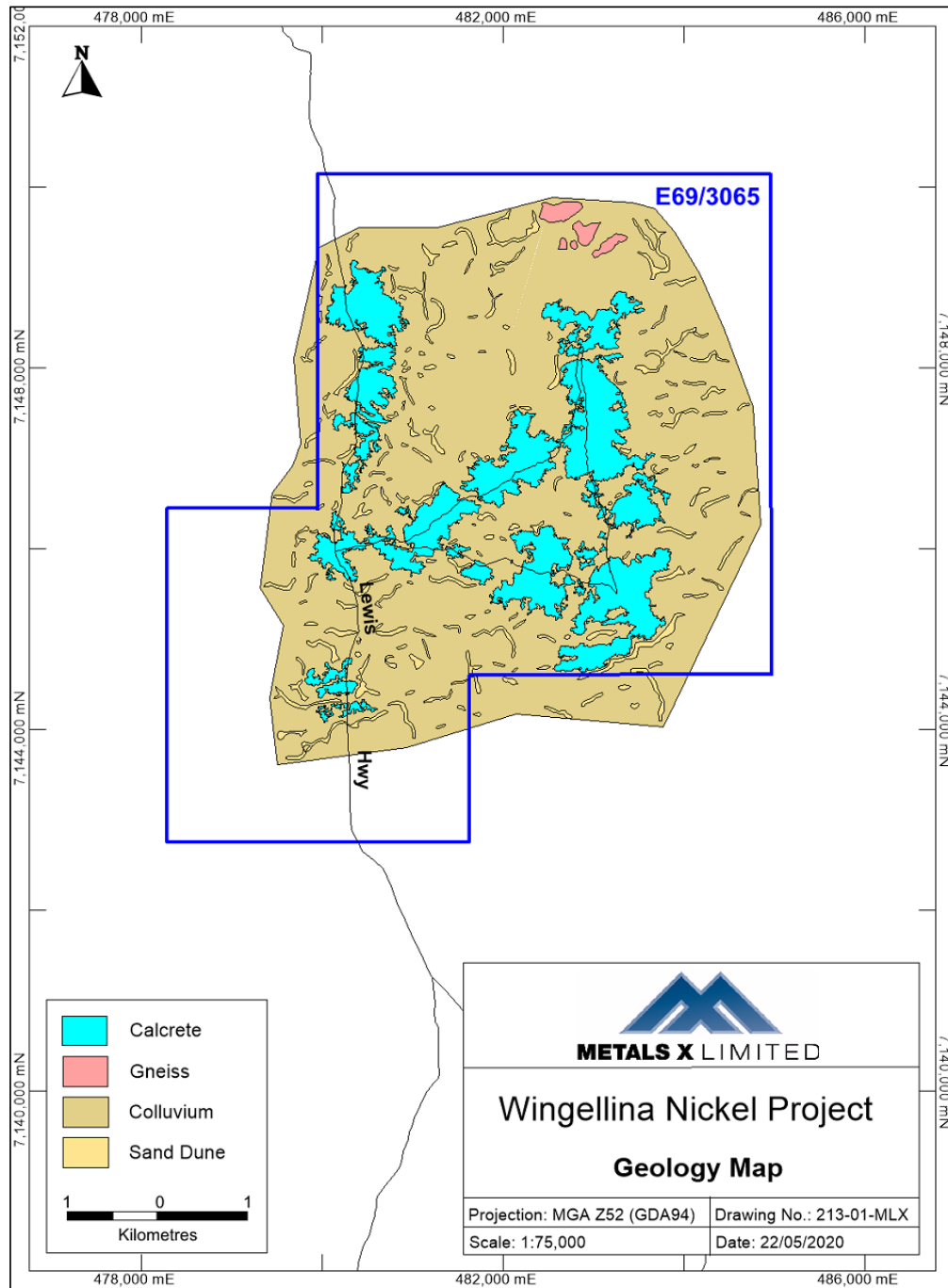

Figure 9: Lewis calcrete deposit geology
Source: Metals X (2020)

For personal use only



4 Previous Exploration

Previous exploration in the CMP has been reviewed extensively by Metals X (2018a, 2018b, 2019, 2020). The following is a synopsis of those reports. To avoid confusion, in the following the present company name “Metals X” is used to denote the same entity previously known as “Metals Exploration” before merging with Bluestone Tin and formally adopting the name Metals X in 2007.

4.1 Wingellina Laterite

4.1.1 Southwestern Mining Ltd, Nickel Mines of Australia NL – 1956 to 1975

Southwestern Mining Ltd (SML), a wholly-owned subsidiary of International Nickel Company (INCO), discovered the Wingellina nickel oxide deposit in 1956 by surface mapping, pitting and hand-auger drilling. SML held the ground as TR1498H until 1960, and subsequently as TR2661H between 1965 and 1975.

SML completed a total of 97,585 m of drilling in 2,943 drillholes over the ensuing 18 years, using a variety of drilling techniques, including churn drilling, wagon drilling, diamond drilling, Becker drilling, percussion drilling and rotary air blast (RAB) drilling. They sampled at 5 ft intervals (1.52 m) and assayed 65,057 samples for nickel, cobalt, and iron. Not all holes lie within the current nickel oxide resource.

In 1959, to more accurately assess the subsurface ore configuration, SML sank four vertical shafts to depths of up to 151 ft (46 m) below the surface for a total 448 ft (136 m) of shafts plus 720 ft (220 m) of cross-drive development. Channel samples indicated that the shafts were sunk in high-grade limonite zones. Additional samples were collected by horizontal augering from the ends of crosscuts. SML also carried out airborne magnetic surveys, ground gravity surveys and ground electromagnetic surveys during this period.

Between 1965 and 1970, in a joint venture with Nickel Mines of Australia NL (NMA), SML completed gridding, mapping, geophysical surveys and a considerable amount of RAB drilling to further test the deposit.

In 1966, a 500-tonne parcel of ore previously excavated from the shafts dug in 1959 was sent to Canada for pilot plant scale metallurgical testwork. A second bulk sample of 842 t from shafts and trenches dug into the deposit was shipped to Canada for testing in 1969. Testing assessed several possible extraction methods and concluded that good nickel extractions could be achieved using the reduction roast-ammonium carbonate leach route (Caron process).

In 1970, a feasibility study by SML indicated that the deposit was marginal, and the company withdrew from the area under an arrangement whereby NMA acquired full rights to the property. The ground was retained under SML’s TR2661H which “reverted to Nickel Mines of Australia N/L with the assent of the Western Australian Government”. From 1970 to 1973, NMA drilled a large number of diamond drillholes within and outside the deposit. The sample and drilling records are incomplete for this work.

Following the proclamation of Aboriginal Reserve 17614 in 1975, exploration and mining were no longer permitted in the region, with the resultant withdrawal of NMA from the project.

4.1.2 Hinckley Range Pty Ltd (Acclaim Exploration Ltd and Metals X Ltd) – 2000 to 2008

Exploration activities did not recommence in the area until July 2001 when Hinckley Range Pty Ltd, a subsidiary of Acclaim Exploration Ltd (Acclaim), entered into an Access Agreement with the local aboriginal owners. Acclaim farmed out Hinckley Range to Metals X in 2005 and subsequently sold it to Metals X in 2006.

From 2001 to the end of 2008, Hinckley Range Pty Ltd completed 685 reverse circulation percussion (RC) drillholes for a total of 57,586 m to test the resource at Wingellina. Metals X also completed 18 diamond drillholes to collect samples for density measurements and metallurgical work.

Since 2008, Metals X has completed engineering studies, bench-scale metallurgical testwork, geotechnical diamond drilling, flora and fauna studies, site engineering testing, and logistics investigations. Bulk samples



of the ore were collected for metallurgical testing in 2013 (by wide-diameter (Bauer) drilling) and in 2014 (by trenching).

Since 2016, Metals X has undertaken further metallurgical optimisation studies, processing options studies, investigated infrastructure options, and undertaken an infill drilling program of 41 RC holes within the Mineral Resource area testing higher-grade nickel and cobalt zones. No exploration activity has been conducted since 2018 mainly due to remote community access restrictions as a result of COVID-19.

4.2 Claude Hills/Mount Davies Laterite

Geologists from the South Australian Geological Survey (SAGS) visited the Mount Davies area in 1953–1954. The Mount Davies nickeliferous laterites were discovered at this time. Subsequent work between 1960 and 2001 consisted of various government and academic regional mapping programs and regional geophysical data acquisition.

In November 2001, Austral Nickel Pty Ltd (Austral), a subsidiary of Acclaim, conducted a drilling program consisting of six wide-spaced RC drillholes within EL2777. In 2004, Acclaim completed ground magnetics over selected targets, four diamond drillholes, 557 auger-geochemical drillholes and a high-resolution aeromagnetic survey over the northern half of the tenement. Acclaim initially farmed out in 2005 and then sold Austral to Metals X in 2006.

Work completed from 2006 to 2008 included three areas of RAB drilling totalling 2,550 m in 178 holes, two RC drill programs totalling 730 m in 26 holes, and a ground electromagnetic survey.

Field work for 2009 included geological mapping of the Claude Hills area and the Pipalyatjara calcrete zone, 11,032 m (165 holes) of RC drilling in three areas, diamond drilling in one area, and limited metallurgical testing. The drilling tested for extensions to known nickeliferous laterites at Claude Hills, nickel sulphide and PGE potential in the Claude Hills differentiated mafic sequence, and calcretes in the Pipalyatjara airstrip area.

From 2010 to 2014, Austral completed 582 m of RC drilling in 46 holes, rockchip sampling and mapping, groundwater sampling for both water quality and subterranean fauna, flew an airborne electromagnetic survey over the Giles Formation rocks within the tenement, completed ground electromagnetic surveys, soil sampling, diamond core drilling, and metallurgical testwork.

Fourteen vertical RC reconnaissance holes were drilled in late 2014 to test for nickel laterite mineralisation at the Scarface Zone that lies immediately east of Kalka and Pipalyatjara communities. No significant mineralisation was encountered deemed capable of supporting a resource. No exploration activity has been conducted since 2015.

4.3 Mount Davies Regional

The South Australian government carried out a program of stratigraphic drilling in 2002, which located anomalous copper mineralisation in a diamond hole (DAV-13) west of Kalka. Bornite veinlets (5 m at 0.86% Cu) were intersected marginal to a micro gabbro dyke traversing the Kalka North gabbroic body.

The Mount Davies tenement area was previously held by Delta Gold Limited as EL2584 in a joint venture with Rio Tinto Exploration (RTE). Exploration activities on that tenement include:

- Review of the geology and the nickel exploration potential of the tenement, and petrographic descriptions of 40 samples of various mafic and ultramafic rock types.
- The petrophysical (magnetic and density) properties of 12 samples of ultramafic and mafic rocks from three ultramafic-mafic intrusions were determined.
- A total of 239 stream sediment samples, 44 rockchip and 28 colluvium samples failed to identify any significant geochemical anomalism. A total of 50 laterite samples confirmed the presence of high-grade nickel laterite mineralisation at Scarface and Claude Hills.



- A helicopter-borne electromagnetic survey utilising the low-power frequency-domain GEM2A system and totalling 2,615 line-km was completed over the entire tenement. Total magnetic intensity and digital terrain model (DTM) data were also collected. No high-priority targets were generated by the survey.
- Three trial ground electromagnetic lines were surveyed across three selected prospect areas (i.e. Mount Davies, Scarface-The Hook, and Claude Hills) but the results proved inconclusive.
- Six vertical RC holes (RC00PWN001-006), totalling 713 m, tested a weak helicopter-borne electromagnetic conductor on the eastern edge of the Michael Hills intrusion. The holes intersected some minor disseminated fine-grained sulphide within pyroxenite and norite. Scanning electron microscopy (SEM) probing of selected sulphide-bearing samples identified pyrrhotite, chalcopyrite and traces of pentlandite that, combined, comprised less than 1% of the sample. No significant assays were returned from the drill samples.

Exploration in 2009–2015 was carried out on EL5184 by Austral under the terms of the Farm-In and Joint Venture Agreement and subsequent purchase agreement with RTE. Work completed included low-impact seismic surveys, geochemical sampling, airborne and ground electromagnetic surveys, RAB, RC and diamond drilling. In 2012, a SPECTREM airborne electromagnetic survey was flown over the tenement. In 2013, follow-up ground electromagnetic surveys of anomalies defined by the SPECTREM survey defined several drill targets in the Ilitjata Homelands area, 7 km south of Pipalyatjara. Heritage surveys of the electromagnetic target areas denied access to the best electromagnetic anomalies. A diamond drillhole was completed on one of the secondary targets in 2013–2014, locating barren sulphides and graphite. No exploration activity has been conducted since 2015.

4.4 Lewis Calcrete

Before the granting of E69/3065, no mineral exploration had been carried out previously on the tenement. The geology of the Bates 1:100,000 map sheet was published by the Geological Survey of Western Australia (GSWA) in 2011.

Detailed mapping of the extensive calcrete deposit outcrops was undertaken from August 2015 to October 2015 to use as a basis for planning future work programs. In 2015, Metals X completed drilling of 89 shallow RC holes to test the calcrete deposits. A total of 579 RC samples were assayed for a 17-element suite by fused disc x-ray fluorescence (XRF), and one water sample was assayed. Selected samples of five RC holes were tested for acid reactivity.

Metals X carried out drilling of a total of 91 shallow vertical RC holes in December 2019 for a total of 618 m. Sampling was undertaken at 1 m intervals vis a cyclone splitter. The majority of the holes were drilled to a depth of 6 m below surface, with six holes drilled to 18 m depth to be used for future environmental monitoring of the water table.

The drill sampling was undertaken at 100 m centres and is part of a longer-term drill program that has been planned to define the total resource of the calcrete deposits. Drilling completed to date has achieved coverage of about 20% of the mapped calcrete deposit.



5 Mineral Resources

5.1 Previous Resource Estimates

Historical Mineral Resource and Reserve estimates are discussed here in the Report. However, a Competent Person has not undertaken the work necessary to verify the historical estimates as current estimates under JORC (2012). As such, the historical estimates should be considered to be indicative only and should not be relied upon. The historical estimates are not considered to be current Mineral Resources or Ore Reserves, as they are superseded by the current Mineral Resource estimates, prepared in accordance with JORC (2012) guidelines, presented in Section 5.2 of this Report.

In 1967, INCO completed a small estimate for Wingellina – estimating less than a third of the contemporary Mineral Resource estimate tonnages, but with a very similar grade tenor. A dry bulk density factor of 1.0 t/m³ was applied and the estimate was reported above a cut-off grade of 1% Ni.

In 2001, Peebles, using all of INCO's historical drilling data for Wingellina, estimated initial unconstrained Inferred oxide resources for the project, which was slightly larger than the current estimate, but at a slightly lower grade tenor. A slightly higher bulk density factor of approximately 1.2 t/m³ was used in this instance, but a reported above a lower cut-off grade (0.5% Ni).

In January 2002, following Acclaim's first drill program at Wingellina and using a nominal bulk density factor of 1.5 t/m³, Geostat Services calculated a global Mineral Resource estimate reported above a 0.5% Ni cut-off, and producing an estimate similar in magnitude to the current Mineral Resource estimate; the resource was considered to be Indicated.

In July 2002, the geological model was significantly revised by Acclaim following the completion of a geological base map compiled from drillhole geological information (both newly compiled from INCO's logs and newly acquired by Acclaim's drilling), geophysical interpretation and limited traverse mapping which enhanced understanding of the geological lateral and depth constraints, and other factors determining the limits to mineralisation. The new geological model resulted in a significant increase in the number and complexity of sectional mineralisation outlines during interpretation. Outlines were initially interpreted on paper sections and later digitised in Micromine. The outlines were then wireframed in Micromine. The validated wireframes, along with drillhole data, were sent to Geostat Services, for geostatistical analysis of nickel, cobalt and iron distributions and block modelling. An unsupported nominal dry bulk density factor of 1.5 t/m³ was again applied for the derivation of the resource (July 2002).

In November 2005, Metals X re-interpreted the sectional resource to confirm the previous interpretation. The sectional model was wireframed in Vulcan, with ordinary kriging used to estimate grade. A cut-off grade of 0.5% Ni and a global density of 1.5 t/m³ was used to allow comparison with the Acclaim calculations. Only nickel was estimated in this preliminary work, with a substantially larger tonnage estimate, 66% of which was considered Measured and Indicated.

In March 2006, DataGeo Geological Consultants was contracted to undertake an updated Mineral Resource estimate for Metals X for the Wingellina deposit. A sectional mineralisation interpretation was created by Metals X geologists based on the geological interpretation of the mineralised zones. A 0.5% Ni envelope was applied to constrain the resource estimate. The sections were modelled in Vulcan, with grade estimated utilising ordinary kriging for nickel, cobalt, and Fe₂O₃. This model was subsequently updated in March 2008, and then again in April 2008, as new data was acquired. The resulting estimate generated a reportable resource again similar in terms of tonnage and grade tenor to the current 2016 estimate using a global dry bulk density of 1.28 t/m³.

In 2010, Metals X undertook a Mineral Resource estimate for the Claude Hills deposit which resulted in the definition of a small Inferred Resource. The resource was estimated using an inverse distance squared method and represents an equivalent to approximately 1% of the Wingellina estimate at a similar grade



tenor, but the estimate is considered to be an early-stage estimate and not yet materially significant to the overall resource base for NICO.

5.2 2016 Mineral Resource and Reserve Estimate

Mineral Resource estimations completed by Metals X in 2008 and 2016 for the Wingellina Project are shown in Table 5.

Table 5: Mineral Resource estimation for the Wingellina and Mt Claude Projects

0.5% Ni cut-off grade	Classification	2008			2016 Metals X			% Difference tonnes	% Difference metal
		Tonnes	Grade	Metal	Tonnes	Grade	Metal (t)		
Wingellina									
Nickel	Measured	68,847,000	1.00	688,500	37,600,000	0.98	368,000	-45%	-47%
	Indicated	98,623,000	0.97	956,600	130,900,000	0.91	1,193,000	33%	25%
	Inferred	15,727,000	0.97	152,600	14,100,000	0.87	122,000	-10%	-20%
	Total	183,197,000	0.98	1,798,000	182,600,000	0.92	1,684,000	0%	-6%
Cobalt	Measured	68,847,000	0.08	53,700	37,600,000	0.075	28,000	-45%	-48%
	Indicated	98,623,000	0.08	74,000	130,900,000	0.072	94,600	33%	28%
	Inferred	15,727,000	0.07	11,000	14,100,000	0.065	9,100	-10%	-16%
	Total	183,197,000	0.08	138,700	182,600,000	0.07	131,700	0%	-5%
Fe ₂ O ₃	Measured	68,847,000	48.71	33,535,000	37,600,000	45.94	17,260,000	-45%	-49%
	Indicated	98,623,000	46.39	45,751,000	130,900,000	45.55	59,611,000	33%	30%
	Inferred	15,727,000	42.73	6,720,000	14,100,000	41.25	5,832,000	-10%	-13%
	Total	183,197,000	46.95	86,006,000	182,600,000	45.30	82,701,000	0%	-4%
Claude Hills 2010									
Nickel	Measured	-	-	-	-	-	-	-	-
	Indicated	-	-	-	-	-	-	-	-
	Inferred	-	-	-	33,000,000	0.81	270,000	-	-
	Total	-	-	-	33,000,000	0.81	270,000	-	-
Cobalt	Measured	-	-	-	-	-	-	-	-
	Indicated	-	-	-	-	-	-	-	-
	Inferred	-	-	-	33,000,000	0.07	22,700	-	-
	Total	-	-	-	33,000,000	0.07	22,700	-	-
Total Central Musgrave Project									
Nickel	Total	-	-	-	215,600,000	0.91	1,954,000	-	-
Cobalt	Total	-	-	-	215,600,000	0.07	154,400	-	-

Notes: Mineral Resources are reported inclusive of Mineral Resources modified to produce the Ore Reserve. Figures have been rounded to the appropriate number of significant figures. The 2016 MLX MRE was reported in accordance with the current 2012 edition of the JORC Code. The 2008 Wingellina MRE and 2010 Claude Hills MRE were reported in accordance with the 2004 edition of the JORC Code. Source: Metals X (2017)

During 2016, Metals X reviewed the April 2008 resource model for Wingellina in detail and according to JORC (2012) guidelines. It concluded that the model was somewhat “smoothed” with an observed underestimation of the higher-grade ore distribution within the deposit. As a result, a revised model was initiated.

The re-interpretation strategy was guided by the geological interpretation. A low-grade (>0.5% Ni) envelope, which was re-interpreted from the 2008 model was initially defined. A high-grade domain (>1.0% Ni) was subsequently interpreted as a result of implicit modelling of nickel at progressively higher cut-off grades and the observed continuity of the higher grades. This 1% Ni cut-off grade was considered appropriate for the high-grade domains as a result of ore-waste boundary analysis using log probability plots, which indicated a



break in the data population at this grade. Domain boundary analysis conducted in Isatis also lent support to the use of a 1.0% Ni boundary.

There was an Ore Reserve declared by Metals X as of 30 June 2016 (Table 6). Information in the 30 June 2016 Annual Mineral Resource Commentary indicated metal prices used were equal to the Phase 1, 2008 Feasibility Study, plant recovery of 91.2% for Ni and 86.5% for Co, mining costs of \$3.67/t mined and processing cost of \$83.30/t milled.

Table 6: Ore Reserve estimation for the Wingellina Project

Project	Ore Reserve category	Ore Mt	Nickel		Cobalt	
			Grade (% Ni)	Nickel (kt Ni)	Grade (% Co)	Cobalt (kt Co)
Wingellina	Proved	-	-	-	-	-
	Probable	168.4	0.93%	1,561	0.07%	122.6
	Total	168.4	0.93%	1,561	0.07%	122.6

Source: Metals X (2016)

CSA Global is of the opinion that the 2016 Metals X Mineral Resource estimation parameters, methodologies and conclusions are in accordance with industry practice and the JORC (2012) guidelines. A detailed peer review of the Resource Model is recommended to examine all relevant parameters in the updated Mineral Resource estimate. With expected changes to these parameters and other modifying factors, it is anticipated a new Ore Reserve estimate would need to be declared with an updated PFS.



6 Mineral Processing Studies

In May 2020, CSA Global conducted a process review of the assumptions made in the processing component of the Wingellina 2008 Phase 1 Feasibility Study and how they translate into proposed processing methods, productivity, and operating costs. The high-level review of the Feasibility Study was limited to the process design for a high-pressure acid leaching (HPAL) process for the Wingellina Project.

The process review for the Phase 1 Feasibility Study was completed by Aker Solutions (Aker). The primary objective of the study was to eliminate various processing options and to estimate operating and capital costs to an accuracy of $\pm 25\%$. These objectives, and cost accuracy ranges, are normally those associated with a PFS-level study, and the Aker study is therefore considered by CSA Global to be accurately considered a PFS rather than an FS.

It should be noted that the JORC and VALMIN reporting standards have lifted significantly since 2008, as have the regulatory requirements of the ASIC and ASX.

6.1 Aker Feasibility Study

Aker carried out the Phase 1 Feasibility Study to design and cost a processing plant to treat ore from the Wingellina deposit. Based on a review of the batch testwork that had been performed on Wingellina ore before 2007 which was aimed at identifying a suitable processing flowsheet, Aker concluded that the HPAL processing route was the favoured option for treating Wingellina ore and limited its study to this technology.

In May 2020, Malachite Consulting (on behalf of CSA Global) carried out a high-level review of the Aker Phase 1 Feasibility Study, including a brief review of preliminary metallurgical testwork, a review of the critical design aspects of the HPAL operation, and an assessment of Aker's estimate accuracy in terms of engineering, capital costs and operating costs. Included in the capital cost discussion was a benchmarking exercise against recently completed HPAL projects which provided a range of probable capital costs for a project of this type.

6.2 Metallurgical Testwork for 2008 Feasibility Study

The preliminary metallurgical testwork for the Phase 1 2008 Feasibility Study was undertaken by SGS Minerals Metallurgy (SGS) with supporting testwork undertaken by TUNRA (The University of Newcastle Research Associates).

In brief, the testwork programs covered the following aspects of the metallurgical process:

- TUNRA: Investigation and testwork on the material handling properties of Wingellina ore and calcrete.
- SGS: Batch testwork on a single composite ore sample, from ore preparation through to mixed hydroxide precipitation.

The various testwork reports were reviewed and the following observations were made:

TUNRA

TUNRA completed its report "Flow Properties of Nickel Ore" in July 2008. TUNRA is a reputable laboratory and undertakes a range of flow property tests ranging from conveyor transport to bulk flow through bins, including recommended materials of construction.

The testwork undertaken for Wingellina was on a single ore sample and a calcrete sample. While the Wingellina process flowsheet does not include ore beneficiation and has a relatively simple ore feed system to the mill, the testwork completed at TUNRA for the Stage 1 FS should be regarded as sighter testwork. Further testwork needs to be undertaken on a range of ore composites that would represent the various mineralisation domains.

. The 14 ore samples came from spear samples of composites from 890 two metre intercepts from 105 RC drillholes throughout the deposit that were drilled during the 2006 resource definition drill program.



The batch testwork included feed preparation, feed thickening, HPAL, primary neutralisation, counter-current decantation thickening, secondary neutralisation, mixed hydroxide precipitation, scavenger precipitation and manganese precipitation.

Additionally, a series of calcrete activity tests were conducted on four calcrete samples to investigate the potential of the calcrete to be used for neutralising the acidic pulps.

SGS is a reputable metallurgical laboratory having undertaken extensive testwork on nickel laterite ores for a significant range of projects. This high-level review has not identified any material issues with the sighter testwork results and the testwork results are appropriate for a PFS.

The following observations have been made on the sighter testwork results:

- The composite ore sample, used for the testwork, graded 0.963% Ni, 0.089% Co, 0.73% Mn, 10% Si and 1.15% Mg, thus mainly limonitic ore with low magnesium and high manganese content.
- The potential to upgrade the ore by crushing and screening was examined. The results showed the cobalt grades decreased with little effect on the nickel grade, thus no benefit in beneficiation.
- Feed thickening produced acceptable underflow solids densities of 48%.
- HPAL achieved 92–97% nickel and cobalt extraction, which is typical for nickel laterites.
- The optimal acid consumption at 296 kg/t was low but in line with low aluminium and magnesium content in the ore sample. In-house calculations have confirmed the SGS acid consumption.
- Commercial limestone was used for primary neutralisation as the calcrete sourced from Wingellina gave poor results.
- Tailings thickening for the counter-current decantation operation had acceptable underflow solids of 37–39% but with high overflow solids, up to 695 ppm. Wash efficiencies were not determined, and the thickener results could be materially worse had calcrete been used for neutralisation.
- Secondary neutralisation using commercial limestone at pH 4.3 and 5.5 achieved 100% iron removal plus most of the aluminium (94–99%) and chromium (95–98%); however, losses of nickel were between 1.1% and 2.4%. Further testwork is required to optimise the solution neutralisation, with SGS suggesting that pH 4.5 is the optimal point.
- Mixed hydroxide precipitation using magnesia was trialled for several stoichiometric addition rates, with nickel in product ranging from 28% to 34%, cobalt 4.3% to 5.1%, and manganese 4.1% to 5.7%.
- Nickel precipitation efficiency varied from 88% to 99%, depending on the dosage of magnesia. Two-stage mixed hydroxide precipitation was not tested.
- Scavenger precipitation using commercial lime (CaO) gave poor results with longer retention times showing probable redissolution of nickel and cobalt. For the shorter retention time of 60 minutes, nickel recovery ranged from 64% to 72%.
- SGS has provided a number of recommendations for further testwork, some of which are used commercially.
- Overall, the testwork program did not allow for process optimisation and the results produced need to be regarded as indicative and not suitable for engineering design.

Aker referred to SGS variability testwork which was undertaken on eight composite ore samples; however, this testwork only commenced in August 2008 and no testwork results were included in the data room.

The Aker Feasibility Study report could not take into account the variability testwork as this testwork commenced after the completion of the engineering study.

In addition, Aker refers to an SGS proposal for continuous pilot plant testwork. This testwork, together with the variability testwork, would be essential for a Bankable Feasibility Study.



6.3 Metallurgical Testwork Review (2009 to 2018)

Additional testwork was undertaken post the 2008 Aker Feasibility Study and the following observations were made.

CSIRO (2008)

CSIRO completed its report on “Preliminary tests for Mn removal from Metals X Wingellina Laterite leach residue slurry by oxidative precipitation with SO₂/air mixtures” in August 2008 but was not included in the Stage 1 Feasibility Study. The purpose of this testwork was to remove the high levels of manganese from the HPAL leach solution before mixed hydroxide precipitation. Manganese, if not removed from the solution, would result in high impurity levels in the mixed hydroxide product, resulting in penalties. The manganese in the HPAL leach solution was approximately three times the cobalt concentration.

The CSIRO testwork produced mixed results, with testwork at lower pH being ineffective for manganese removal and at pH >4, resulting in high co-precipitation of nickel and cobalt. Further testwork is required to achieve the optimal conditions for manganese removal without incurring unacceptable losses of nickel and cobalt.

AMMTEC (2009)

During 2009, testwork undertaken by AMMTEC involved scrubbing and material characterisation testwork on two ore samples (limonite and saprolite) and a calcrete sample. This work included sample preparation, head sizings, scrubbing tests, solubility tests, viscosity tests, settling tests, comminution tests and reactivity tests. However, the results of this testwork have not been made available.

Ammonia Leach Testwork (2010)

In 2010, the Burnie Research Laboratory undertook a program of preliminary atmospheric ammonia/ammonium carbonate leach testing of the Wingellina ores. These leach tests indicated negligible nickel dissolution under these conditions and no further work was recommended.

Also during 2010, the Burnie Research Laboratory undertook a program of preliminary oxide flotation test work on Wingellina ores. The completed testwork returned a best recovery of 20.7% and no further work was recommended.

Ion Exchange Testwork (2011)

In 2011, Fenix Hydromet was commissioned to undertake laboratory-scale scouting studies to investigate the applicability of ion exchange applied as resin-in-pulp (RIP) for the recovery of metals from high-pressure autoclave leach liquors. In these simple tests, overall recovery was 85% for nickel and 63% for cobalt. Fenix Hydromet concluded that nickel recoveries would likely be increased through using a higher percentage of resin in the RIP contact or adding additional RIP stages; the resin is close to its maximum loading under the conditions used which could have limited a higher nickel recovery being achieved.

Scandium Testwork (2012)

During 2012, SGS Lakefield undertook test work to investigate scandium recovery from the HPAL solutions using solvent extraction and precipitation. The consultant metallurgist concluded that the testwork was very successful.

Pilot Plant Feed Characterisation Testwork (2013)

During 2012, MLX used a Bauer Drill Rig to collect 88 tonnes of Wingellina ore and 5 tonnes of calcrete representing the potential acid neutralisation material.

The completed testwork on the Wingellina ore included head assay, ore characterisation (UCS, impact work index, abrasion index, bond rod mill index, and bond ball mill index), HPAL and rheology while the work on the calcrete included head assay, specific gravity, ore characterisation, and acid reactivity.



In addition, subsamples were submitted for TUNRA testwork at the University of Newcastle which included moisture determinations, consolidation and shear tests, compression tests, wall friction tests and bulk density tests. Additional tests included angle of repose and belt surcharge angles.

Sulphide Precipitation using Hydrogen Sulphide Gas Testwork (2013)

Sulphide precipitation testwork on Wingellina ores was completed in two phases. The Phase 1 programs consisted of investigating the precipitation characteristics of nickel and cobalt using sodium hydrosulphide (NaHS).

In 2013, SGS Lakefield completed Phase 2 of the testwork program which investigated the precipitation characteristics of nickel and cobalt using hydrogen sulphide gas (H₂S) as the precipitating reagent.

This testwork confirmed that sulphide precipitation can be used effectively to recover nickel and cobalt from neutralised leach solutions expected from the HPAL treatment of Wingellina ores. Nickel precipitation ranged from 95.6 to 99.2% while cobalt precipitation ranged from 94.8 to 99.8%.

Bulk Sampling and POSCO Nickel Extraction Process (PosNEP) Testwork (2014)

During 2014, a 120t bulk sample of Wingellina ore at the “average reserve grade with respect to nickel and cobalt” was collected from a series of trenches.

The collected samples were sent to POSCO in South Korea for pilot testing using its propriety “POSCO Nickel Extraction Process” (“PosNEP”) technology.

The PosNEP trials were successful with the additional benefits of using minimal water compared to other processes and the ability to recycle the main reagents.

Sulphate Crystallisation Testwork (2017 to 2018)

In late 2017, SGS Minerals Metallurgy were engaged to undertake sulphate crystallisation testwork on Wingellina ores. The testwork program comprised several steps: sample preparation, pressure acid leach, leach PLS treatment via pre-reduction, and primary neutralisation, recovery of nickel and cobalt by ion exchange, secondary neutralisation, zinc removal, followed by manganese removal, before cobalt recovery in a second solvent extraction stage.

The results of this work were positive and highlighted potential processing refinements warranting further investigation. Importantly, high-quality nickel and cobalt sulphates as potential battery feedstock were produced.

6.4 Processing Technology Options

Following a review of post-2008 testwork commissioned by Metals X mostly involving downstream processing, Malachite Consulting reviewed a wide range of processing technologies that were not considered as part of the Aker Phase 1 Feasibility Study. Some 17 technologies were evaluated in the fields of commercial and alternative pyrometallurgy, pyro/hydrometallurgy and hydrometallurgy processes.

A comparison table and ranking chart was developed to help quantify the respective options in terms of proven technology, process suitability for Wingellina, nickel recovery, product market, plus capital and operating costs. Based on the high-level assessment, six processing options were selected, which cover a wide range of processing technologies, and were recommended to be carried forward for further investigation in a Scoping Study.

A comparison of the laterite processing options is shown in Table (below).

Table 7: Technology comparison chart

Option	Advantages	Disadvantages
Commercial Pyromet Processes		
Ferronickel	<ul style="list-style-type: none"> Simple flowsheet 	<ul style="list-style-type: none"> High capital and operating costs



Option	Advantages	Disadvantages
	<ul style="list-style-type: none"> Well proven technology Ferronickel product ideal for stainless steel Can sell at premium to LME High nickel recovery 	<ul style="list-style-type: none"> Requires low cost energy source Only suitable for high grade saprolite ore Slag chemistry critical, limits on MgO and SiO₂ No recovery of cobalt Significant environmental issues
NPI	<ul style="list-style-type: none"> Simple flowsheet Well proven technology Rapid production ramp-up High nickel recovery Lower capital costs than RKEF 	<ul style="list-style-type: none"> High operating costs Only suitable for high-grade ore (>2.2% nickel) Low-grade product (5–15% nickel) NPI only suitable for stainless steel smelters No recovery of cobalt Significant environmental issues
Alternative Pyromet Processes		
Vanyukov	<ul style="list-style-type: none"> Simple flowsheet Well proven technology in former USSR Ferronickel product ideal for stainless steel Suitable for low grade laterite ores with high Fe:Ni ratios High nickel recovery 	<ul style="list-style-type: none"> High capital and operating costs Can produce 20% nickel in ferronickel (Not commercially proven) No recovery of cobalt Significant environmental issues
Submerged arc furnace	<ul style="list-style-type: none"> Simple flowsheet Suitable for low grade laterite ores with high Fe:Ni ratios High nickel recovery 	<ul style="list-style-type: none"> High capital and operating costs Low-grade product (10–15% nickel) NPI only suitable for stainless steel smelters Not commercially proven No recovery of cobalt Significant environmental issues
Krupp Renn	<ul style="list-style-type: none"> Simple flowsheet Suitable for low grade laterite ores with high Fe:Ni ratios 	<ul style="list-style-type: none"> High capital and operating costs Low grade product Issues with accretion build-up on calciners Not commercially proven
Direct reduction/magnetic separation	<ul style="list-style-type: none"> Simple flowsheet Lower capital costs than RKEF Suitable for low-grade laterite ores with high Fe:Ni ratios Extensive research undertaken 	<ul style="list-style-type: none"> High operating costs Low-grade product dependent on efficiency of magnetic separation Magnetic separation of fines is challenging Nickel recovery expected to be lower than RKEF Not commercially proven
Envirosteel	<ul style="list-style-type: none"> Simple flowsheet Lower power costs than RKEF Suitable for low-grade laterite ores with high Fe:Ni ratios High nickel recovery 	<ul style="list-style-type: none"> High operating costs Low-grade product (15% nickel) Not commercially proven Significant environmental issues
ISA Smelt	<ul style="list-style-type: none"> Simple flowsheet Lower capital costs than RKEF Suitable for low-grade laterite ores with high Fe:Ni ratios High nickel recovery 	<ul style="list-style-type: none"> High operating costs Low-grade product expected Not commercially proven Significant environmental issues
Pyromet/Hydromet Processes		
Caron process	<ul style="list-style-type: none"> Selective leaching of nickel Minimal corrosion issues High reagent recycle and recovery Commercially proven 	<ul style="list-style-type: none"> High capital costs Very high energy costs Low overall plant recovery, especially cobalt. Suitable only for limonitic ores Outdated technology Significant environmental issues
PosNEP process	<ul style="list-style-type: none"> Improved front end to Caron process (hydrogen reductant) High-grade NPI (18–20% nickel) 	<ul style="list-style-type: none"> High operating costs Low cobalt recoveries Complex hydromet flowsheet



Option	Advantages	Disadvantages
	<ul style="list-style-type: none"> High reagent recycle and recovery Low capital costs (<US\$10/lb nickel) Commercially proven 	<ul style="list-style-type: none"> Dependent on high HCl and H2 recoveries
Hydromet Processes		
HPAL	<ul style="list-style-type: none"> Low acid consumption Acid plant energy credits High cobalt credits High recovery of nickel and cobalt. 	<ul style="list-style-type: none"> High capital costs (US\$20 to 40/lb nickel) High operating and maintenance costs Suitable only for limonitic ores Long project ramp-up HPAL plants are complex and difficult to operate High technical and capital risk
Atmospheric leach (H ₂ SO ₄)	<ul style="list-style-type: none"> Conventional equipment technology Able to handle feed variability 	<ul style="list-style-type: none"> High capital and operating costs, similar to HPAL Very high acid consumption Handling of iron slurry and residues difficult Lower nickel/cobalt recoveries than HPAL Process not commercially proven
Atmospheric chloride leach (HCl)	<ul style="list-style-type: none"> Atmospheric leaching reduces capex Can treat limonites and saprolites High extraction of nickel and cobalt 	<ul style="list-style-type: none"> High operating and capital costs Exotic materials of construction Expensive reagents (i.e. HCl) Relies on regeneration of acid using pyrohydrolysis High net acid consumption Process not commercially proven
Direct Nickel (HNO ₃)	<ul style="list-style-type: none"> Atmospheric leaching reduces capex Non-exotic materials of construction Can treat limonites and saprolites High extraction of nickel and cobalt 	<ul style="list-style-type: none"> High capital costs (US\$24/lb nickel) High operating costs dependent on efficiency of nitric acid regeneration Expensive reagents (i.e. HNO₃) Regeneration of nitric acid is energy intensive High net acid consumption Process not commercially proven
SAL	<ul style="list-style-type: none"> Atmospheric leaching reduces capex Lower capex than RKEF or HPAL Non-exotic materials of construction Can treat limonites and saprolites 	<ul style="list-style-type: none"> High operating costs Leach recovery dependent on efficiency of sulphation process High acid consumption Process not commercially proven
Heap leach	<ul style="list-style-type: none"> Simple flowsheet Lower capital costs Short project construction and ramp-up Small plants are economically viable Low capital exposure and risk 	<ul style="list-style-type: none"> High operating costs dependent on acid consumption Heap permeability critical Impacted by ore variability and mineralogy High iron extractions Lower nickel/cobalt recoveries than HPAL Not ideally suited to limonite ores
In-situ leaching (ISL)	<ul style="list-style-type: none"> Lower capital investment Front-end processing costs reduced No mining involved No tailings disposal of waste rock and leach tailings 	<ul style="list-style-type: none"> Poor metals accounting and recoveries Dilute metals in abstracted leach solution Bed rock permeability critical Low water table adds complexity Extensive testwork required Potential environmental permitting issues

A ranking of the laterite processing options as applied for the Wingellina Project is shown in Table (below).

For personal use only



Table 8: Technology ranking

Process option	Proven technology	Process suitability	Nickel recovery	Product market	Operating costs	Capital costs	Environmental impact	Overall ranking
Ferronickel	5	1	5	4	1	3	3	22
NPI	5	3	4	3	3	5	2	25
Vanyukov	1	1	4	4	2	3	3	18
Submerged arc	1	1	4	4	2	3	3	18
Krupp Renn	3	1	2	2	2	3	2	15
Direct reduction/ magnetic separation	3	4	3	3	3	5	3	24
Envirosteel	1	3	4	4	2	3	3	20
IsaSmelt	1	1	4	4	2	3	3	18
Caron	5	3	4	3	1	4	3	23
PosNEP	5	4	4	4	2	5	3	27
HPAL	1	4	5	5	3	1	4	23
Atmospheric leaching (H2SO4)	3	3	4	5	2	1	3	21
Atmospheric chloride acid leaching (HCl)	1	2	4	5	2	2	3	19
Direct Nickel	3	4	4	5	2	2	4	24
SAL	1	2	3	5	2	3	3	19
Heap leach	3	2	3	5	3	5	4	25
In-situ Leach (ISL)	1	3	3	5	3	5	4	24

The purpose of the Scoping Study would be to shortlist two or three process options that have the potential of being technically and commercially viable. The shortlisted process options would be further developed and engineered in a PFS, to select one process option for advancing to a Bankable Feasibility Study.

6.5 Product Options

As presented in this Report, several processing technologies can be employed for nickel laterites, and these can produce a wide range of product options.

The selection of the final product needs to take into account future markets, both the projected pricing and the capacity of the market to absorb the new production.

In the case of ferronickel, this can be sold at a discount or premium to London Metal Exchange (LME) prices, depending on current market conditions. In some cases, credits can be obtained for the iron units, if sold into the stainless steel industry.

In the case of intermediate products, these are typically sold to refineries at a discount to LME prices. These discounts are influenced by the demand for nickel, impurity levels and the ability of the refinery to handle the intermediate feed. Most nickel refineries can process mixed sulphides, due to their low impurity levels; however, the refineries which can treat mixed hydroxides and mixed carbonates are limited. Available refinery capacity also needs to be considered.

High-grade nickel and cobalt sulphates may attract a premium to LME depending on market conditions, however, limited market data is available, and it would be dependent on the product quality.

Battery-grade nickel and cobalt sulphates should attract a premium to LME; however, as more production comes onto the market, this premium would likely reduce.



The final consideration is the complexity and capital cost for producing the various products, especially for a remote site operation that has a fly-in/fly-out workforce.

A summary of various nickel products which are currently traded (nickel metals, nickel salts and intermediate products) is provided in this review.

6.6 Recommendations

6.6.1 Resource Estimate

To optimise the process design, the nickel laterite resources need to be defined in terms of their geological and metallurgical properties, i.e. limonite, saprolite, smectite, nontronite etc. (better known as ore domains). Classification of the different geological and metallurgical domains is a key prerequisite for geometallurgical modelling and subsequent pit optimisation.

6.6.2 Mine Plan

Mine planning needs to smooth the ore composition being fed to the process plant, as far as possible. If HPAL is the adopted process, the aluminium and magnesium concentrations will need to be smoothed out, given that these are the major acid consumers, with HPAL being indifferent to iron content. If the heap leaching process is adopted, then the iron and magnesium concentrations will need to be smoothed.

Pit optimisation studies need to also take into account the various ore domains and the optimal sequencing of ore into the process plant, which will vary depending on the process route selected.

6.6.3 Aker Phase 1 Feasibility Study

While the Aker Phase 1 Feasibility Study (PFS or Class II Study) was completed to an acceptable standard, the study was based on flawed assumptions for the ore feed to the HPAL operation, which is fundamental to the entire engineering design.

The major concern with the Aker engineering study was the low acid consumption assumed based on SGS testwork on a non-representative ore composite (i.e. 296 kg/t vs about 400 kg/t) estimated based on the average life-of-mine plan.

In addition, the engineering study does not take into account the significant variability in the average annual ore composition as detailed in the life-of-mine plan. The day-to-day operational variability in ore composition is expected to be significantly greater than the life-of-mine year-on-year variability.

The low acid consumption assumed and the ore variability, would impact significantly on the capacity of the HPAL operation, given that the acid plant has been based on the maximum commercially available size. As a result, it is estimated that the plant capacity could be downrated from 38,500 tpa nickel to 30,500 tpa nickel.

The Aker engineering study needs to be updated, taking into account the following:

- Updated life-of-mine plan with smoothed ore composition.
- Orebody variability and impact on process design.
- Process Design Criteria need to specify an operating range instead of a single value (e.g. ore feed composition, acid consumption, ore throughput, etc.).
- Benchmark the Aker study against data from previously constructed HPAL plants, for
 - ramp-up schedule;
 - plant operating availability;
 - autoclave productivity;
 - autoclave vent velocity;
 - metallurgical recoveries;
 - maintenance requirements and costs;
 - updated transport and reagent costs; and



- capital and operating costs.

The update to the Aker study should not require a complete reworking of the engineering design calculations but would require an adjustment to the key operating and engineering design parameters.

The current outlook for commodity pricing (e.g. sulphur) plus transport, energy, labour and construction costs would need to be factored into the updated report. The operating and capital costs would then be factored from the Aker study estimates to provide an updated report.

6.6.4 Processing Technologies

Most nickel laterite projects are challenging, and few have achieved technical and commercial success. The Wingellina nickel laterite deposit is particularly challenging, being a low-grade nickel deposit with minor cobalt by-product credits. The project is located well inland in a remote part of Australia and is not supported by any significant infrastructure.

The proposed strategy for selecting a viable processing technology is to initially undertake a detailed Scoping Study review of up to six potential processes. The Scoping Study would need to include mine optimisation, mass and energy balances, operating and capital expenditure estimates plus environmental and risk assessments. No testwork is envisaged for the Scoping Study and the focus would be on commercially proven processes and emerging process technologies that have been well-researched.

The purpose of the Scoping Study would be to shortlist two or three process options that have the potential of being technically and commercially viable. The shortlisted process options would be further developed and engineered in a PFS, which would enable these options to be compared with an updated Aker HPAAL study.

The purpose of the PFS would be to select one process option for advancing to a Bankable Feasibility Study.

The strategy of considering a wide range of technologies initially should avoid the sequential assessment of possible processing options which is time-consuming. In addition, a sequential approach does not allow for an objective assessment to be made on the same independent basis.

Based on a high-level review and ranking of a wide range of processing technologies, it is proposed to consider six process technologies that ranked most highly.

Based on a high-level review and ranking of a wide range of processing technologies the CSA Global report of May 2020 proposed six processing options for the Scoping Study as follows:

1. Nickel pig iron
2. PosNEP
3. Direct reduction/magnetic separation
4. Direct nickel
5. Heap leach
6. *In situ* recovery

This selection of processing options provides a wide range of technologies including pyrometallurgical, combined pyrometallurgical/hydrometallurgical, hydrometallurgical and emerging technologies which are not yet commercially proven.

In Situ Recovery

Of all the above options CSA Global considers the ISR option to warrant further consideration given its potential to offer a substantially lower capital pathway to emissions-free “green” nickel and cobalt.

ISR, also commonly referred to as ‘*in situ* leaching’ (ISL) or *in situ* extraction (ISE), is one of the most effective methods to address the costs of mining. The critical feature of ISR is transferring a significant proportion of hydrometallurgical processing to mineralised bodies in the subsurface to directly obtain solutions of metals of interest.



Evaluation of the suitability of deposits for ISR requires different and modified approaches compared to traditional mining/extraction techniques. Furthermore, some deposits that are currently uneconomic to extract using traditional mining methods may be potentially profitable as ISR operations. An important reason for the slow uptake of ISR technology is the lack of experience and expertise in ISR, and the need for a somewhat more complex approach to Mineral Resource estimation. Each deposit, or even a part of the deposit, requires a specific approach.

ISR uses solutions that are pumped through the mineralised body "*in situ*" (underground) to recover metals by leaching. *In situ* mining is the "*removal of the valuable components of a mineral deposit without physical extraction of the rock*".

Typical ISR mines comprise well field(s) and an extraction process plant. Leaching solutions are pumped into the mineralised zone(s) through a network of injection bores and extracted by production bores. In the process, the leaching solution dissolves the metals of interest, which are brought to the surface in a pregnant solution. The pregnant solutions are treated at an extraction plant to produce a chemical concentrate of the target metal(s). As a result, there is little surface disturbance and no tailings or waste rock generated.

However, for ISR to be effective, the mineralised body needs to be permeable (either naturally or artificially) to the solutions used and located such that the solutions do not contaminate groundwater away from the mineralised body. Target minerals need to be readily soluble by the leaching solutions in a reasonable period, and there should be a reasonable consumption of leaching reagents.

The Wingellina Project is potentially amenable to the application of the ISR method for the extraction of Ni and Co.

In the case of Wingellina, the leach solution would be pumped into the *in situ* ore body and would then need to percolate down to the water table, to allow for the abstraction of the leachate. This configuration is required where the water table lies below the mineralised zone.

The economic advantages of ISR include:

- Lower mine development costs, including processing plant and infrastructure, in comparison with conventional open pit and underground mines.
- The ability to commence production with lower capital costs and subsequently increase production.
- The flexibility of production capacity. Production can be reduced during periods of lower prices and increased when prices are higher.
- Low grades are not necessarily a critical factor for ISR. The size of the deposit is also much less important for ISR operations. 'Grade-thickness' of mineralised bodies is more important than grades for successful economic extraction.

The economics of ISR mines primarily depends on the following parameters:

- Flow rate capacity of the wellfields (input capacity of injection wells and extraction capacity of production wells).
- Concentration of extracted component(s) in pregnant solutions.
- The overall level of extraction of mined component(s).
- The ratio of Liquid to Solid (L:S) required to achieve the desired extraction of the mined component(s). This ratio is calculated based on the volume of solutions passed through the operational block over the whole period of operation and on the tonnage of the operational block. The L:S ratio is a key parameter for ISR and is dependent on the dynamics of leaching. The lower the ratio, the more favourable the economics of the project.

ISR allows the extraction of mineralisation with minimal disturbance to the existing natural conditions. In contrast to underground and open pit mining, there are no:



- Large open pits
- Rock dumps or tailings storage
- Dewatering of aquifers

The impact of ISR projects on the environment is therefore much less than for conventional mining methods, as long as projects are adequately planned, operated, and closed, using industry best practice.

6.6.5 Product Options

The decision on which product to produce is ultimately dependent on market terms achieved plus capital investment and operating costs.

Pyromet Processing

Producing ferronickel is preferred over NPI; however, the decision is dependent on capital investment, operating costs and market prices achieved. It is expected that a high-grade nickel pig iron (18–20% Ni) could be readily marketable and would achieve competitive market pricing.

Hydromet Processing

Producing a mixed sulphide as an intermediate product is the preferred product option, given its high metal content and attractive market pricing.

Producing LME deliverable metals on a remote site adds unnecessary complexity to the processing circuit. Given that nickel and cobalt refining capacity is available worldwide, attractive terms should be available for a mixed sulphide intermediate product.

Similarly, the production of “battery-grade” nickel and cobalt sulphate was not recommended at this stage for a remote site, given the lack of a proven process flowsheet and the significant operational complexity.

Should a market review indicate a substantial premium to LME is achievable on a long-term basis, then a separate refining facility located close to Adelaide or Perth, or a joint venture with another company looking to produce “battery-grade” products, could be considered.

6.6.6 Market Study

As there is a significant range of market prices for the various intermediate products, smelter feeds, battery-grade salts and final LME metal, it is recommended that a market study be undertaken. The market study should ascertain the likely range of market prices for each of the product options, as this will influence the choice of the process flowsheet.



7 Mining Studies

7.1 Introduction

In June 2020, CSA Global conducted a gap analysis of the assumptions made in the mining component of the Wingellina 2008 Phase 1 Feasibility Study and how they translate into proposed mining methods, productivity, and operating costs.

The mining study for the Phase 1 Feasibility Study was completed by Coffey Mining (Perth). The primary objective of the study was to eliminate various mining and ore handling options and to estimate operating and capital costs to an accuracy of $\pm 25\%$. The objective and cost accuracy range are those normally associated with a PFS and the Coffey Mining study is therefore considered on the whole as a PFS, albeit with some shortcomings, as detailed in this Report.

CSA Global considers the mining methodology to be fairly straightforward with the process material proposed to be extracted using conventional open pit mining methods, utilising load and haul equipment to freely excavate material, and deliver ore and blend as it is fed into the primary crusher using front-end loaders. An allowance for 10% of total volume requiring blasting has been made, which adequately accounts for small occurrences of harder rock. Waste-to-ore strip ratios are very low, feeding to a run-of-mine pad at a rate of 4.3 Mtpa. It was planned that ore would be stockpiled low and the average waste-to-ore stripping ratio in the first 20 years was estimated to be approximately 0.5:1. The life-of-mine stripping ratio was approximately 1.1:1.

7.2 Mining Study Gaps

The following items are recognised as gaps from analysis of the Coffey Mining report in the 2008 Phase 1 Feasibility Study, which will need to undergo further investigation to bring the studies up to a PFS level.

7.2.1 *Hydrogeological Model*

The hydrogeological review of Wingellina in 2008 was based on limited data and should be considered as preliminary. A more detailed hydrogeological model was subsequently developed as part of the EPA approvals process.

7.2.2 *Geotechnical Model*

Only limited geotechnical drilling sampling and analysis had been undertaken for Wingellina according to the 2008 Phase 1 Feasibility Study. Geotechnical recommendations for open-cut wall slope angles are important to reduce waste mining while ensuring overall project economic forecasts are achieved. The slope considerations for the pit designs have been based on a conservative view of a typical lateritic nickel mine and thus additional geotechnical drilling should be planned.

7.2.3 *Resource Model*

The Mineral Resource estimate for the 2008 Stage 1 Feasibility Study was under the old JORC Code (2004). The Mineral Resource estimate was subsequently updated to JORC (2012) as of 30 June 2016 (Table 7, taken from the Metals X website), although little supporting information was given. While tonnes were very similar in the 2012 Mineral Resource estimate, nickel grade dropped from 0.98% to 0.92%. A peer review of the Resource Model is recommended to examine all relevant parameters in the updated Mineral Resource estimate. Section 5 of this Report provides more detail.



Table 7: CMP Mineral Resource estimate

Project	Mineral Resource category ¹	Mt ²	Nickel		Cobalt	
			Grade (% Ni)	Nickel (kt Ni ²)	Grade (% Co)	Cobalt (kt Co ²)
Wingellina (cut-off 0.50% Ni)	Measured	37.6	0.98%	368	0.07%	28.0
	Indicated	130.9	0.91%	1,193	0.07%	94.6
	Inferred	14.1	0.87%	122	0.06%	9.1
	Total	182.6	0.92%	1,684	0.07%	131.7
Claude Hills (cut-off 0.50% Ni)	Measured	-	-	-	-	-
	Indicated	-	-	-	-	-
	Inferred	33.3	0.81%	270	0.07%	22.7
	Total	33.3	0.81%	270	0.07%	22.7
Total Central Musgrave Project	Measured	37.6	0.98%	368	0.07%	28.0
	Indicated	130.9	0.91%	1,193	0.07%	94.6
	Inferred	47.4	0.83%	392	0.07%	31.8
	TOTAL	215.8	0.91%	1,953	0.07%	154.4

Notes:

1. Mineral Resources are reported inclusive of Mineral Resources modified to produce the Ore Reserve.
2. Tonnes are reported as million tonnes (Mt) and rounded to nearest 100,000; nickel tonnes are reported as thousand tonnes (kt) and rounded to the nearest 1,000 tonnes; cobalt tonnes are reported as thousand tonnes (kt) and rounded to the nearest 100 tonnes; rounding may result in some slight apparent discrepancies in totals.
3. The Metals X Wingellina MRE was reported in accordance with the current 2012 edition of the JORC Code
4. The Claude Hills MRE was reported in accordance with the 2004 edition of the JORC Code

7.2.4 Ore Reserves

There were no Ore Reserves declared in the 2008 Stage 1 Feasibility Study by Coffey Mining. However, there was an Ore Reserve declared by Metals X as of 30 June 2016 and reported on its website (Table 8). Information in the 30 June 2016 Annual Mineral Resource Commentary indicated metal prices used were equal to the Stage 1 2008 Feasibility Study, plant recovery of 91.2% for nickel and 86.5% for cobalt, mining costs of \$3.67/t mined, and processing cost of \$83.30/t milled. With expected changes to these parameters and other modifying factors, it is anticipated a new Ore Reserve estimate would need to be declared with an updated PFS.

There is always room to improve the economics and to continue to enhance the confidence of Reserves. The 2019 gap and flaw analysis was undertaken to determine the areas which could improve the confidence of the project overall and to move the project towards a definitive DFS and BFS. It is not to say that Phase 1 PFS was not properly undertaken or inadequate. There has also been a significant amount of work undertaken since 2008 which has added to confidence of the project.

CSA has reviewed the validity of the Reserves which were compiled in 2016 and is of the view that the Reserves are valid and have been reported in accordance with the JORC Code. CSA is also of the view that the additional proposed work being undertaken by Nico leading to an updated PFS in the first two years will warrant an update of the Reserves given the expected higher degree of confidence and economics.



Table 8: Wingellina nickel-cobalt project Ore Reserve estimate

Project	Ore Reserve category ¹	Ore Mt	Nickel		Cobalt	
			Grade (% Ni)	Nickel (kt Ni ²)	Grade (% Co)	Cobalt (kt Co ²)
Wingellina	Proved	-	-	-	-	-
	Probable	168.4	0.93%	1,561	0.07%	122.6
	Total	168.4	0.93%	1,561	0.07%	122.6

Notes:

1. The Ore Reserve is based on the Wingellina Mineral Resource estimate as of 30 June 2016 with applied modifying factors, at a cut-off grade of 0.5% Ni.
2. Tonnes are reported as million tonnes (Mt) and rounded to nearest 100,000; nickel tonnes are reported as thousand tonnes (kt) and rounded to the nearest 1,000 tonnes; cobalt tonnes are reported as thousand tonnes (kt) and rounded to the nearest 100 tonnes; rounding may result in some slight apparent discrepancies in totals.

In July 2020, CSA Global conducted a gap analysis of the assumptions made in the mining component of the Wingellina 2008 Phase 1 Feasibility Study and how they translate into proposed mining methods, productivity, and operating costs.

Under the JORC Code, Reserves can only be stated if a minimum of a Pre-feasibility-level study has been undertaken. The Modifying Factors have been extracted from the JORC Code (the Australasian Code for the Reporting of Exploration Results, Mineral Resources and Ore Reserves, 2012 Edition). The bulk of the information reviewed was contained in the 2008 Phase 1 Feasibility Study but where applicable, more up-to-date information was obtained from the “Central Musgrave (Wingellina) Nickel-Cobalt Project Draft Information Memorandum (February 2019) (Inf Mem)”.

CSA has reviewed the validity of the Reserves which were compiled in 2016 and is of the view that the Reserves are valid and have been reported in accordance with the JORC Code.

Table 9 below identifies the key elements of the PFS broken down into the recommended JORC categories. The following are explanations of how the table is set up:

- Criteria – recommended guidance from the JORC Code
- Reviewed – “yes” if the criteria have been identified in the documents
- Gap – “yes” if there is a gap that needs to be updated or reviewed in a future PFS
- Comments – commentary surrounding the gap to be addressed.

The findings are that most of the key elements require some work to achieve a PFS-level of confidence for Ore Reserve estimation.

Table 9: Wingellina nickel-cobalt deposit – gap analysis

Criteria	Reviewed	Gap	Comments
Mineral Resource estimates			
Resource model	Yes	Yes	Model updated by Metex Nickel in 2016, based on the 2008 model prepared by DataGeo Geological Consultants.
Measured Resources			37.6 Mt @ 0.98% Ni and 0.07% Co at cut-off grade of 0.50% Ni.
Indicated Resources			130.9 Mt @ 0.91% Ni and 0.07% Co at cut-off grade of 0.50% Ni.
Inferred Resources			47.4 Mt @ 0.83% Ni and 0.07% Co at cut-off grade of 0.50% Ni.
Mining factors			
Cut-off grades	Yes	Yes	Variable cut-off grade applied in optimisation. CSA Global recommends the application of equivalent metal grade to encompass nickel and cobalt grades, plant recoveries and variable acid consumption.
Mine geotechnical	Yes	Yes	Most geotechnical data was obtained through logging. Limited quantitative geotechnical information was used in this study. Not up to PFS standard suitable for Ore Reserves. An overall slope of 40° was applied inclusive of ramps. Needs closer review due to high clay content within final walls.



Criteria	Reviewed	Gap	Comments
Hydrogeological studies	Yes	Yes	Based on limited data supplied by Metex. Groundwater yields are expected to be low due to high clay content. A more detailed hydrogeological model needs to be developed.
Site visit	Yes	No	Site visits were conducted by Coffey and Metex Competent Persons.
Optimisation	Yes	No	Whittle 4X used. It is understood only Measured and Indicated resources were used (no Inferred material) but unclear. Several scenarios were run.
Mine Design	Yes	No	There were several pit designs based on the "20-year mine life pit shell". Conformance was excellent from shell to design (83.2–85.0 Mt), nickel (1.10–1.08%). Designs based on Caterpillar 777 trucks and 24 m haul roads and 40° overall slope angles. No waste dump designs were done, only volumes. 20 pit designs were completed.
Mining method	Yes	Yes	Conventional open-cut drill and blast with 100-tonne excavators and 55-tonne trucks. The pit designs were based around 90-tonne trucks. Need to resolve mining fleet. Recommended bench height of 4 m and flitch height of 2 m.
Grade control	No	Yes	No mention of grade control within the documents.
Mining model	No	Yes	A mining model was not provided.
Mining dilution	Yes	Yes	"Limited" mining dilution allowed for.
Mining recovery	Yes	No	97% mining recovery allowed for. Considered satisfactory for equipment size.
Minimum mining widths	No	Yes	No mention of minimum mining widths.
Mining schedule	Yes	No	Schedule based around Process of 4 Mtpa and mining rate of 6 Mtpa. Staged pit designs are effectively used to get the highest-grade nickel (1.32% for two years) upfront for optimising cash flow. Mining schedule of 20 years.
Mine infrastructure	Yes	No	It is understood the mine is to be set up as an owner operator model. Infrastructure allowed for includes mining equipment, workshop, offices, computers, software, vehicles, and haul road works.
Inclusion of Inferred Resources	Yes	No	Pit optimisation work and pit designs based on Measured and Indicated resources only.
Sensitivity of project to Inferred Resources	Yes	No	Impact of Inferred adds an extra 10% plant tonnes. However, the impact on cash flow is negligible based on discounted cash flow results.
Metallurgical factors			
Metallurgical process			Metallurgical testwork is referred to in the Process options part of the report.
Metallurgical testwork			Refer to the Process options section of the report.
Bulk samples/pilot plant studies			Refer to the Process options section of the report.
Deleterious elements			Refer to the Process options section of the report.
Appropriate mineralogy to meet product specifications			Refer to the Process options section of the report.
Environmental			
Environmental studies – status	Yes	No	The Project was referred to the Environmental Protection Authority ("EPA") in September 2013. The EPA concluded that the Wingellina proposal may be implemented to meet the EPA's objectives subject to certain conditions. The imposed conditions were accepted by MLX and in September 2016 MLX received a signed Ministerial Statement (No. 1034) that the Wingellina nickel project proposal may be implemented.
Waste rock characterisation	Yes	No	During 2014, Outback Ecology was engaged to undertake a program of waste characterisation. All waste samples assessed were classed as non-acid-forming.
Waste storage sites and design options	Yes	Yes	Waste dump and tailings locations were identified but not designed. Significant sites have been identified and allowed for within the mining plan.

For personal use only



Criteria	Reviewed	Gap	Comments
Status of approvals for residue storage and waste dumps	Yes	Yes	Currently, an exploration licence (E69/535) – needs to be converted to a mining licence. Waste dump areas as per EPA submission and approval.
Infrastructure			
Infrastructure, haul roads, offices	Yes	Yes	Site locations have been chosen for tailings, offices, haul roads but have not been finalised.
Availability of land for plant development	Yes	Yes	A plant location was chosen within E69/535 but no mining licence has been applied for.
Power	Yes	Yes	A co-generation plant using steam from sulphur-burning acid plant and natural gas to have connected power of 53.5 MW with a consumption rate of 37.3 MW. Mereenie gas field is located 400 km to the northeast. The final configuration will be based on chosen process option.
Water	Yes	No	Requirement of 1,200 m ³ per hour of raw water per annum. Studies carried out in 2010–2012 in two main areas within 100 km of the project site indicate sufficient water is available. Testing and modelling completed (Information Memorandum).
Transportation (particularly for bulk commodities)	Yes	No	Favoured transportation routes are to Impadna or Indulkana Sidings on the Adelaide-Darwin rail, both about 500 km from the project area. Substantial road upgrading would be required.
Labour	Yes	Yes	Location requires a fly-in/fly-out workforce on a site-based contract. The program needs to be designed.
Accommodation	Yes	Yes	Accommodation facility required at the site with dry camp arrangements, separate to the local community.
Costs and revenue factors			
Capital costs – mine	Yes	Yes	2008 estimate of A\$23.7 million of mining capital including A\$17.6 million for Owner fleet and A\$3.8 million for working capital. Not based on quotes. Has not been updated.
Derivation of and assumptions made re CAPEX	Yes	Yes	Based on project engineering requirements and replacement capital equipment during mine life. Estimates in A\$ (June 2008) and based on estimations to an accuracy of ±25%. Contingencies allowed for.
Operating costs – mine	Yes	Yes	Based on Coffey Mining's in-house database; \$4.12/t. Mining operating costs estimated in Information Memorandum as A\$6.22/t. Needs updating.
Operating costs – other	Yes	Yes	Total site operating costs of A\$117/t of ore including mining and estimated HPAL OPEX (2008 estimate).
Methodology used to estimate OPEX	Yes	No	OPEX is considered to be to an accuracy of ±25%. Estimates all generated in A\$ and no escalation has been allowed for. Based on first principles.
Metal price and penalties	Yes	Yes	Nickel price US\$20,000/t and \$0.85 forex. Cobalt price US\$45,000/t (2008 estimates). Will depend on product options (still to be decided).
Assumptions and sources re metal pricing	Yes	Yes	Fair market view back in 2008.
Allowances for deleterious elements	Yes	No	The only deleterious element at this point is chromium VI. Provision made for a reduction in the recycle leach.
Derivation of transport charges	Yes	Yes	Detailed offsite infrastructure and logistics study carried out. Evaluated rail, roads, and transport options. Needs updating.
Exchange rates and their source	Yes	Yes	Used US\$/A\$ 0.85 for the project (2008 estimate). Needs review.
Sell costs, including royalties	Yes	Yes	Royalties of 2.5%. Refining costs of A\$1.40/lb used in mining study. Needs updating.
Source, or basis, of treatment and refining charges and penalties	Yes	Yes	Limited information on the refining charges. Need more background.
Market assessment			
Demand, supply and stock situation	Yes	Yes	Study of product options to be undertaken; will likely be different to the 2008 Feasibility Study due to emerging trends and new usages.



Criteria	Reviewed	Gap	Comments
Consumption trends	Yes	Yes	Same as above.
Factors likely to affect demand and supply	Yes	Yes	Same as above.
Customer and competitor analysis	Yes	Yes	Same as above.
Likely market windows	Yes	Yes	Same as above.
Price and volume forecasts, including basis of forecasts	Yes	Yes	Same as above.
Customer specifications, testing and acceptance requirements for industrial minerals	No	No	Not applicable.
Economic analysis			
Inputs to economic analysis	Yes	Yes	Inputs all need to be reviewed and updated. Especially reagent costs, fuel and gas pricing, nickel pricing, forex, and refining charges.
Source and confidence in the economic inputs	Yes	Yes	Same as above.
Net present value ranges	Yes	Yes	Same as above.
Sensitivities to changes in significant assumptions and inputs	Yes	Yes	Same as above. The project is most sensitive to the exchange rate, nickel price and the price of certain reagents (such as sulphur if HPAL is chosen). Needs outlook for 2020 and beyond.
Social			
Status of agreements with key stakeholders	Yes	Yes	Site is currently an Exploration licence – needs to be converted to a mining licence. An updated Environmental and Impact Assessment may be required, to review the approval granted in 01/09/2016 as there is a 5 year time limit on substantial commencement. An Indigenous Land Use Agreement was executed in 2010 with the local community.
Matters affecting social licence to operate	Yes	Yes	Several complex matters including Aboriginal communities, land usage, water usage, fauna and flora, tailings discharge, road construction, which are currently subject to an existing Agreement, but may require review and possibly renegotiation, as project development progresses.
Other			
Natural risk	Yes	Yes	Very early stages. Needs update.
Legal factors and agreements	Yes	Yes	Very early stages. Needs update.
Governmental factors	Yes	Yes	Wingellina sits close to three state/territory borders.
Status of titles and project approvals	Yes	Yes	Very early stages. Needs update.
Risk assessment	Yes	Yes	Risk Management chapter covered in PFS. Needs update.
Classification			
Basis of Ore Reserve classification	Yes	Yes	No Ore Reserve was declared as part of the 2008 Feasibility Study. An Ore Reserve was reported in 2016, estimated by Metex and based largely on 2008 Feasibility Study parameters.

7.2.5 Mine Optimisation and Pit Designs

Coffey Mining produced the report for the mine planning “Mining Study – Phase 1 Feasibility Study” dated July 2008. The pit optimisation for Wingellina was undertaken using a nickel price of US\$20,000/t as compared with the current market price of US\$19,400/t, a cobalt price of US\$45,000/t as compared with the current price of US\$52,500/t and an exchange rate of US\$:A\$ 0.85 as compared to the current price of US\$:A\$ 0.74.

A significant change in metals pricing assumptions used for the pit optimisation would make a material impact on the pit design.



As metal prices, capital costs, operating costs and several modifying factors have changed along with potential changes to mineral resource models, the optimisation of the open-cut deposit will need to be renewed.

For proper costing analysis, waste dumps and backfilling options need to be designed into the mine plan. No waste dump designs have been done previously.

7.2.6 Mine Scheduling

Modern mine scheduling software such as Minemax™ enables superior financial “whole of site” outcomes based on all operating expenditure and capital expenditure within the mine and plant life-of-mine schedule. Previous scheduling is considered simplistic to obtain this information, however, indicated that the deposit is amenable to a diminishing grade mining strategy. The mining schedule indicated that average grades to be achieved over the life of the mine are:

- Years 1–2: 1.33% Ni and 0.12% Co
- Years 3–5: 1.17% Ni and 0.09% Co
- Years 6–10: 1.09% Ni and 0.09% Co
- Years 11–20: 1.05% Ni and 0.08% Co
- Years 21–39: 0.87% Ni and 0.07% Co.

7.2.7 Capital Costs

The mining capital costs used in the 2008 Stage 1 Feasibility Study was \$23.7 million and requires updating.

CSA Global notes that mining capital costs are only a minor component of the overall costs (~1%) as used in the 2008 Feasibility Study.

7.2.8 Operating Costs

Mine operating costs need to be reworked based on the recommended mining fleet and expected fuel costs. The 2008 Coffey Mining study is considered to be on the low side of current expectations at \$6.22/ore tonne. The Ore Reserve estimate declared in June 2016 used \$3.67/t mined in its Whittle optimisation.

CSA Global notes that mining operating costs are only a minor component of the overall costs (~5.3%) as used in the 2008 Feasibility Study.

7.2.9 Waste Rock Characterisation

Waste rock characterisation is required to determine if acid-forming or potentially acid-forming materials are likely to be found in ore, low-grade ore and waste stockpiles. During 2014, Outback Ecology was engaged to undertake a program of waste characterisation for the Wingellina Project to fulfil regulatory obligations for the Public Environmental Review. The assessment aimed to characterise the physical, chemical and geochemical properties of mine waste materials associated with mining activities for the project, to facilitate the development of a preliminary mine waste inventory, to identify preliminary rehabilitation and landform design requirements, and associated recommendations for rehabilitation and mine closure activities.

The physical, chemical and geochemical characteristics of mine waste materials were assessed from 17 representative drill samples from eight drillhole locations. Waste lithology information indicated that the mine waste materials are from 10 dominant lithologies, and could be grouped into five waste categories, namely “gabbro”, “saprock”, “silcrete”, “ultramafic” and “undifferentiated (undiff.) clay”. The undifferentiated clay, which represents approximately 57% of the waste expected to be generated, is sodic, saline, dispersive and also has a generally “low” hydraulic conductivity. These factors indicate that these clayey waste materials are likely to have high potential erodibility.

All waste samples assessed were classed as non-acid-forming. The gabbro and saprock waste materials are physically, chemically and geochemically benign, and are likely to be a valuable source of competent surface armour material for use in the rehabilitation of waste landforms.



7.2.10 Infrastructure Requirements

Site locations have been nominated for the tailings storage facility, offices, haul roads, plant site, pit outlines, workshops, and fuel farms. The PFS is the appropriate time to test these proposed locations and to come up with alternative capital cost-saving solutions.

On a project scale, it is well known the site is challenged by its isolation from existing infrastructure in respect of roads and rail. While there is no way to avoid this dilemma, creative thinking and engineering can potentially find solutions where isolation is less of an impediment to a successful operation.

The indicative site layout as proposed in the 2008 Feasibility Study is shown in Figure 10.

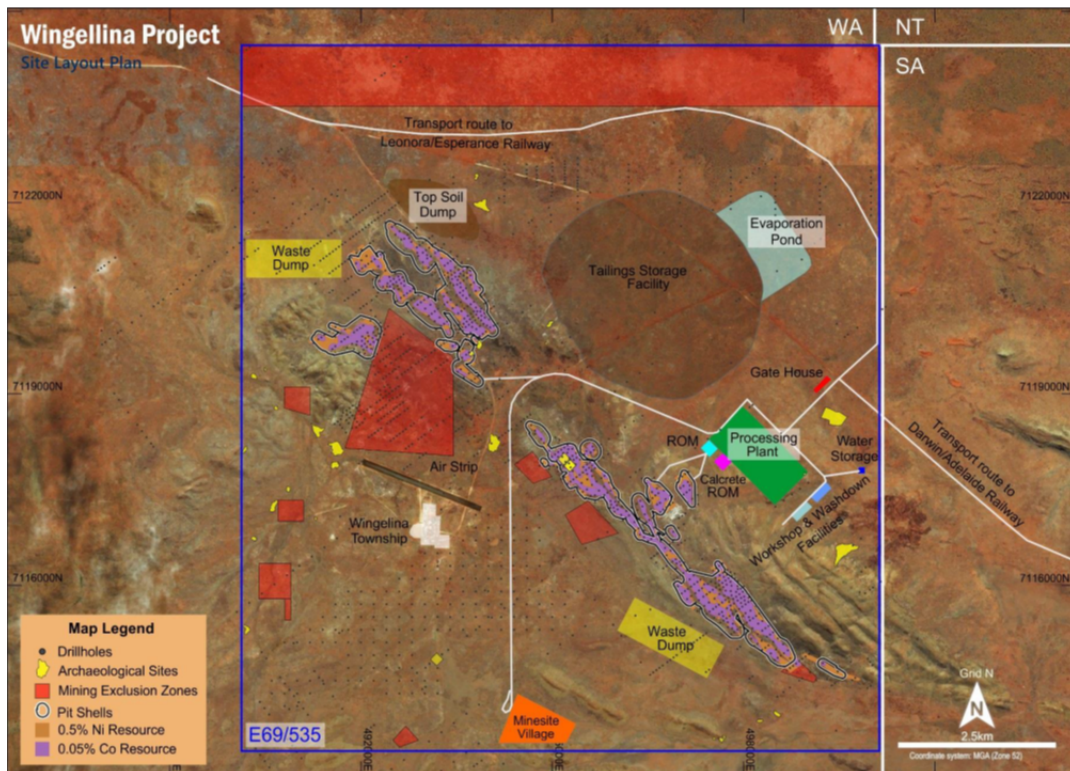

Figure 10: Wingellina 2008 Phase 1 Feasibility Study – indicative site layout

7.2.11 Other Mining-Related Matters

Matters that need to be addressed in the Coffey Mining study include:

- Grade control – no mention of grade control methodology or costing was made in 2008.
- The use of “metal equivalent” grade would be an improvement to using nickel grade alone to define mineralisation.
- A mining dilution factor was not applied in the 2008 Stage 1 Feasibility Study and should be incorporated in future mining studies.
- Fly-in/fly-out roster – based on two weeks on/one week off back in 2008. Needs to be aligned with current industry practice. This will impact mining and administration costs.
- Forex – needs updating.

For personal use only



- A single dry bulk density value of 1.28 t/m³ was used for the Resource Model. Documentation of density determinations indicates separate densities were defined for limonite (1.23 t/m³; 156 samples) and saprolite (1.4 t/m³; 58 samples). Density should be assigned to model blocks according to their lithology.
- Owner Operator vs Contractor Strategy needs to be considered. The 2008 Stage 1 Feasibility Study went with an owner operator strategy for mining fleet and personnel. This is the traditional approach for a long-life mining operation. However, the need for mining flexibility, the location of the deposit and the need to conserve capital costs upfront lead to the potential for a mining contractor fleet.
- Bench height and equipment selection in the 2008 Stage 1 Feasibility Study has been based around two 100-tonne excavators and nine 55-tonne dump trucks. Bench height and equipment selection will be dictated by plant capacity and the stripping ratio that is derived from the optimised mining scheduling studies.

For personal use only



8 Exploration Potential and Proposed Work

Exploration potential in the Project is in three broad categories of confidence level:

- Delineation of cohesive domains of higher-grade material within the existing resource envelopes at Wingellina and Claude Hills for metals of interest such as nickel, cobalt and scandium. The presence of such cohesive domains of higher-grade material could potentially allow a favourable start-up scenario for extraction.
- Continuation of the laterite mineralisation systems beyond the current resource envelopes at Wingellina and Claude Hills.
- Regional exploration for other mineralised systems within the current exploration leases.

Other work is also required to delineate the calcrete resource at Lewis for potential use in the laterite extractive process system flowchart. Current drilling has only covered approximately 20% of the outlined calcrete system mapped at surface.

8.1 Internal High-Grade Resource Domain Delineation

With the increasing cobalt price throughout 2017, Metals X undertook a review of the cobalt inventory of the Wingellina Deposit to investigate higher-grade cobalt domains that could be targeted as a high-grade start-up option. This work resulted in the definition of high-grade cobalt domains within the resource envelope (Figure 11).

Past drilling and mining studies at Wingellina were focused predominantly on optimisation for nickel production. However, within the Wingellina Mineral Resource, which extends over almost 10 km, Metals X has delineated 15 possible high-grade cobalt-nickel domains. Although the 15 domains identified capture a significant quantity of nickel and cobalt, collectively they contain less than 20% of the total contained nickel and cobalt in the CMP.

MLX completed some infill drill testing of the identified high-grade domains with an initial program in December 2017 and a second program in December 2019. Results from the two drilling programs were highly encouraging with mineralisation being intercepted in all the holes drilled. In addition to the high nickel and cobalt grades as expected, several holes intercepted scandium above 120 ppm.

To date, eight of the 15 high-grade cobalt-nickel domains have been infilled with drilling while the remainder require further infill drilling to demonstrate the continuity of higher-grade material. Preliminary optimisation of the high-grade cobalt-nickel domains incorporating the latest drill results is yet to be undertaken. This work would aim to identify a potential higher nickel-cobalt grade, lower capital start-up option for Wingellina.

Following the success of delineating internal higher-grade cobalt domains with elevated scandium at Wingellina, further work is planned to similarly test the concept within the Claude Hills resource envelope.

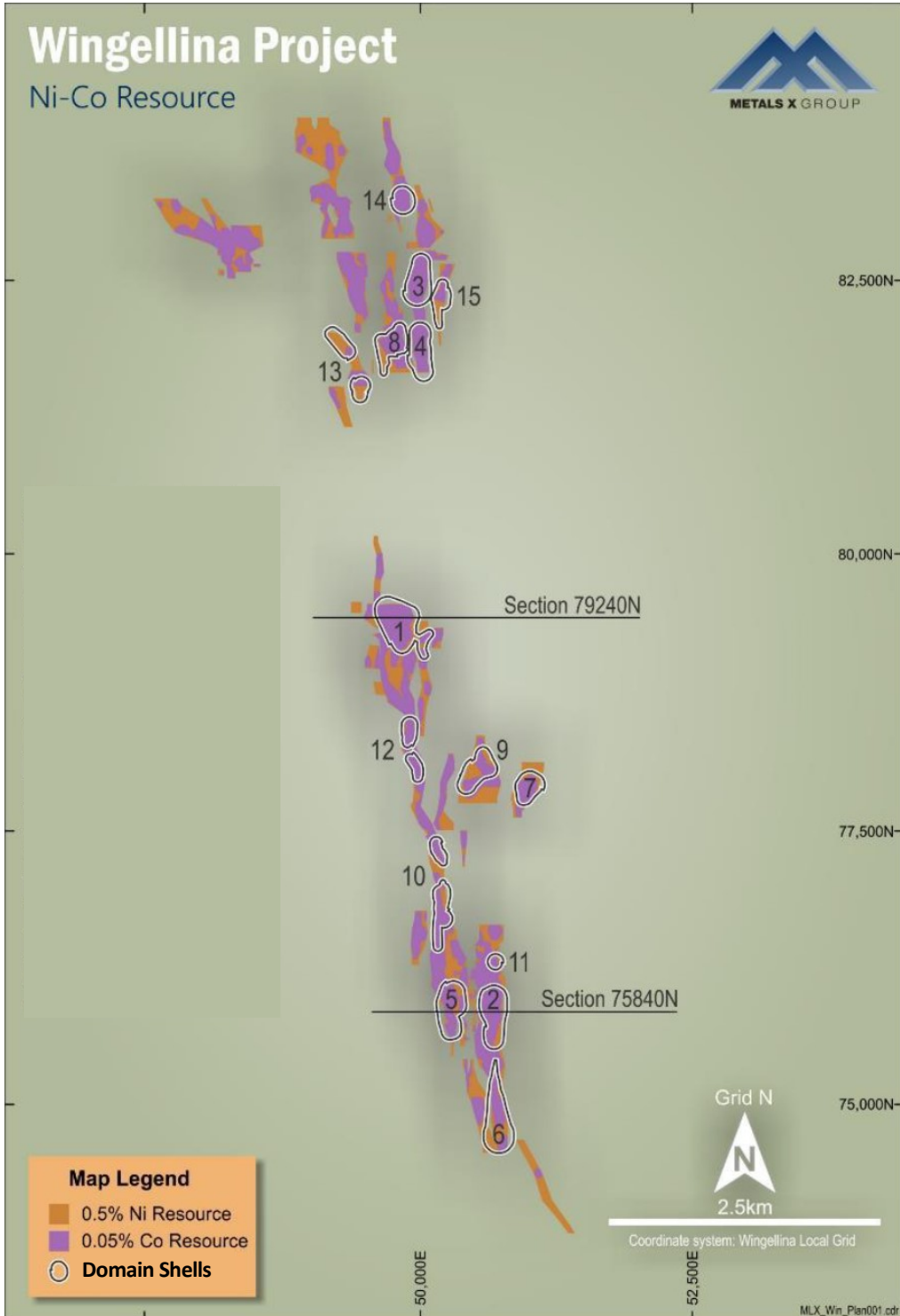

Figure 11: Wingellina Resource outline with high-grade cobalt domains
Source: Metals X (2020)

For personal use only



NICO plans several programs of drilling on the Project to better delineate higher-grade domains within the resource envelopes at Wingellina and Claude Hills, as well as to conduct infill drilling to upgrade Mineral Resource estimate classifications. In summary, NICO will drill:

- Wingellina: 500 m of RC drilling in Year 1 and 500 m of RC in Year 2. Infill drilling and targeting of high-grade cobalt within previously identified domains that require further drilling.
- Claude Hills: 2,500 m of RC drilling in Year 1 and 8,000 m of RC in Year 2. Infill drilling and targeting of high-grade cobalt/scandium domains within the Claude Hills resource envelope. This will give approximately 80% coverage of the Claude Hills deposit at 200 m line spacings with 25 m drill centres along the drill lines and is expected to enable the Inferred status of the Inferred Resource to be reclassified.
- Lewis calcrete deposit: 1,200 m RC drilling of 170 of the remaining 330 holes over the course of Years 1 and 2. This will give approximately 80% coverage of the deposit on 100 m x 100 m centres to the base of the calcrete (expected to be at an approximate depth of 6 m).

8.2 Extension of Existing Mineralisation

Drilling on the Wingellina deposit was ceased based on the knowledge that a substantial resource was already identified within the approximately 10 km of strike of the Mineral Resource estimate envelope. It was deemed that further drilling to increase the strike extent of the mineralisation was not the critical issue for determining the potential economic viability of the deposit. Instead, the focus was turned to tightening drill spacing within the known deposit to increase confidence in Mineral Resource estimate classification and to delineate the higher-grade domains within the known resource.

As such, the deposit is still open in several directions and has not been closed out.

While previous regional exploration has broadly defined the geology and mineralisation of the deposit in three zones along an approximate 15 km strike extent, in CSA Global's opinion, substantial potential exists to increase the size of the Mineral Resource estimate envelope on its margins in several directions.

8.3 Regional Exploration

The targeted ultramafic package of rocks that is the source of the laterite mineralisation in the weathering profile above them is known to wrap around the Birksgate basement gneiss and has been explored extensively for lateritic nickel mineralisation since the 1950s (Figure 5). The Wingellina, Claude Hills and Scarface prospects are the key areas of mineralisation defined to date. SML's testing of the Scarface prospect failed to return any significant limonite mineralisation except in a single angled diamond hole, "A1", within a mixed limonitic-magnesite profile. MLX attempted to get access to the eastern end of the prospect area in 2014 but could not get Heritage clearance at that time. Drilling to the west in 2014 was unsuccessful.

The Musgraves area is known to host several nickel-copper-PGE sulphide nickel deposits associated with mafic-ultramafic rocks of the Giles Complex, such as the Nebo-Babel and Succoth deposits owned by OZ Minerals Limited. Only limited exploration for such sulphide deposits has occurred within NICO's tenements. At this stage, NICO has no plans to conduct regional exploration for this deposit style.

8.4 Lewis Calcrete Deposit

The planned RC drilling program on the Lewis calcrete deposit to 6 m depth is depicted in Figure 12. It is expected that 160 of the holes will be completed in the first two years of the program, giving approximately 80% coverage of the deposit, with the remainder 170 drillholes to be completed in subsequent years.

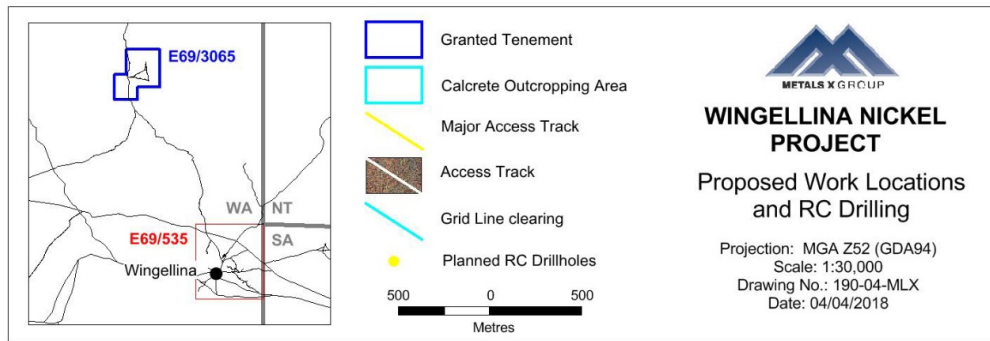
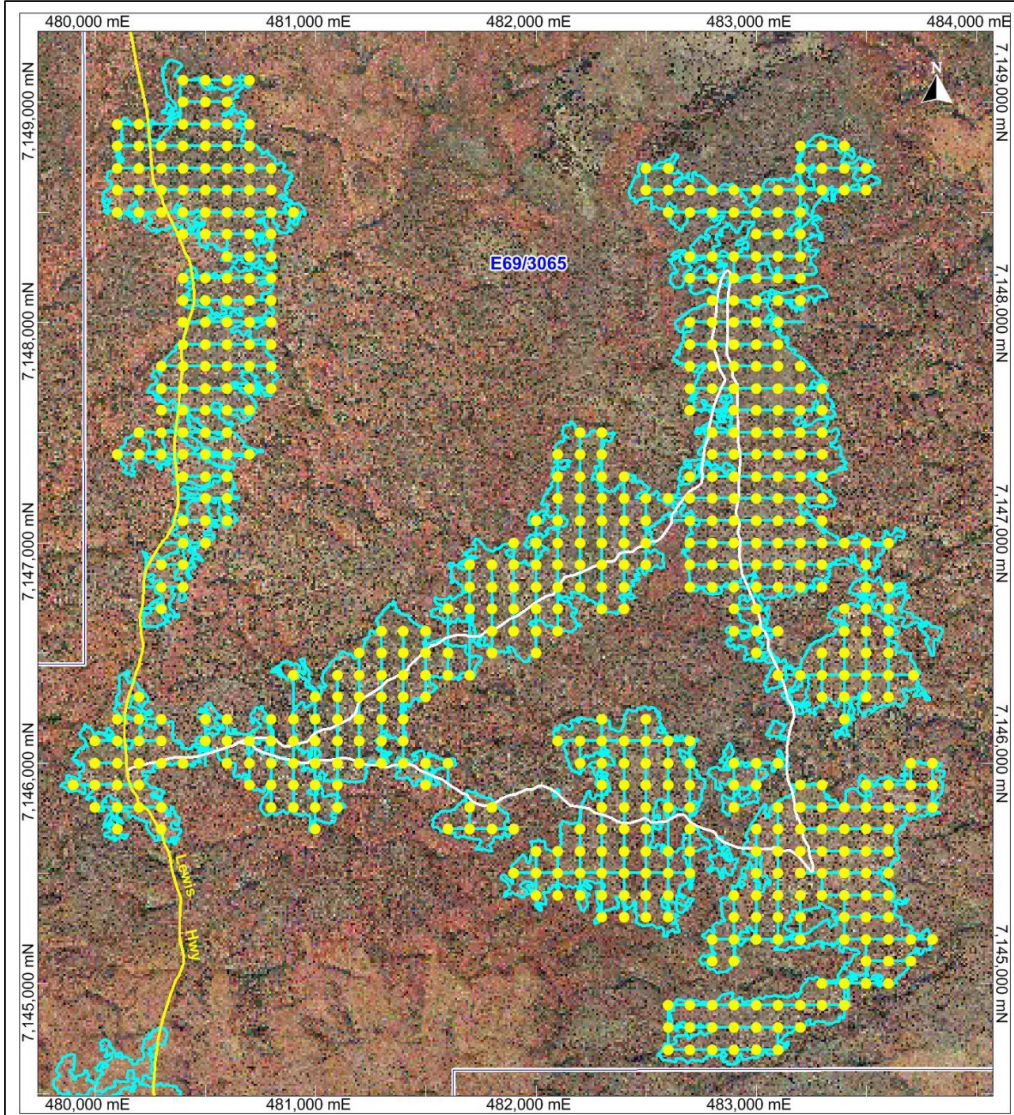

Figure 12: Drill plan for the Lewis calcrete deposit
Source: Metals X (2020)

For personal use only



9 Risks and Opportunities

9.1 Risks

The ability of any project to achieve forward-looking production and economic targets is dependent on numerous factors that are beyond CSA Global's control and that CSA Global cannot anticipate. These factors include, but are not limited to, site-specific mining and geological conditions, management and personnel capabilities, availability of funding to properly operate and capitalize the operation, variations in cost elements and market conditions, developing and efficiently operating the mine, unforeseen changes in legislation and new industry developments. Any of these factors may substantially alter the performance of any mining operation.

The interpretations and conclusions reached in this Report are based on current geological understanding and the best evidence available to the authors at the time of writing. It is the nature of all scientific conclusions that they are founded on an assessment of probabilities and, however high these probabilities might be, they cannot provide absolute certainty.

CSA Global cannot guarantee certainty regarding the future economic viability of the Project. NICO plans to conduct the economic and engineering studies required to determine the economic viability of the CMP.

The CMP comprises a range of stages of advancement from early exploration through to advanced exploration. Risk is reduced at each stage. Exploration is an intrinsically risky process, particularly at an early-stage.

The Closure Management Plan falls within Aboriginal land both within Western Australia and South Australia. CSA Global understands there is a mining agreement in place, and the Company conducts regular consultation meetings with the community involved. NICO will need to maintain good working relationships with the local communities to maintain access for work, and may require additional formal agreements for any future development works. There will be a need to consider the potential impact of an operating mine site on the nearby Wingellina community. The impact of mining and processing operations, which potentially include impacted by dust, noise and other emissions were considered as part of the EPA approval which was received in 2016, and will need to be monitored on an on-going basis, and any impacts mitigated. CSA Global notes that the EPA approval was granted 01/09/2016 and there is a 5 year time limit on substantial commencement, and a possibility exist that the EPA approval may be reassessed.

The processing testwork conducted to date is considered to be at a PFS level. The composite samples used in the testwork will need to be further analysed, and more samples collected to ensure that they are adequately representative of the variability of the whole deposit. Variability within the process feed material has the potential to have a significant impact on production rates and costs. CSA Global notes that Metals X has commenced this body of work.

Geometallurgical studies will allow different domains with the Mineral Resources to be identified and modelled and estimated separately to support more accurate feed blending and reduce plant feed variability.

Only a few nickel laterite projects have achieved technical and commercial success. The Wingellina nickel laterite deposit is particularly challenging, being a low-grade nickel deposit with minor cobalt by-product credits. The project is located well inland in a remote part of Australia and is not supported by any significant infrastructure.

Conventional nickel laterite plants require large capital investments. Project delays and cost overruns have the potential to negatively impact the project value. Detailed feasibility studies at the appropriate stages of project maturity will be completed to manage and contain

A skilled workforce is required to firstly build then operate and maintain the plant. Operating costs are sensitive to the labour requirements and consumable usage (power, water, sulphur, acid, chemicals, etc.).



The processing plant flowsheet is complex and could present significant occupational health and safety risks. However, these risks can be mitigated by adequate process and procedural controls. Environmental impacts will need to be assessed for the management and monitoring of effluents, emissions, and waste management.

Further investigation of a firm market for the nickel and cobalt products is needed. The end product can be varied to suit the market, and an embryonic market for mixed hydroxide precipitate (MHP³) nickel is becoming a focal point as a raw material input to the nickel chemical industry and is set to see further uptake as supply from new projects enters the market, and demand increases for a supply chain that is becoming more geared towards lithium-ion batteries and electric vehicles (Benchmark Minerals, 2020).

To date, only preliminary hydrogeology and geotechnical studies have been conducted, and more detailed studies are anticipated as the project is developed over time.

The interpreted Mineral Resources will need to be domained, to allow a better representation of the different bulk densities that apply to different lithologies, which will result in more accurate tonnage estimates.

Long-term metal prices should be reviewed and the pit optimisation updated, as a significant change in metals pricing assumptions would make a material impact on the pit and waste designs. More detailed mine scheduling of the process feed material will improve the optimised output by maximising grade and reducing variability.

The site is isolated and will require a skilled fly-in/fly-out workforce. The availability of this skilled workforce may be challenged by extended COVID-19 related restrictions. However, it is difficult to anticipate the situation in the future and NICO proposes to monitor developments closely as project feasibility studies are conducted.

There will be a need to consider the potential impact of an operating mine site on the nearby Wingellina community. The impact of mining and processing operations, which potentially include impact by dust, noise and other emissions, will need to be monitored and any impacts mitigated. Early consultation with the community involved is underway.

Archaeological sites and heritage exclusion zones may sometimes represent a restriction to mining operations. However, in this instance, Metals X has completed significant archaeological studies which have delineated the sensitive sites and heritage exclusion zones. Metals X is in the process of consultation and negotiations and considers that it has made substantial progress towards developing a mining agreement with the local Aboriginal landholder group.

9.2 Opportunities

The Wingellina Project can be considered one of the more significant large nickeliferous “pure oxide” limonite accumulations in world rankings. The high iron grades and low magnesium mineralogy of the ore is a strength of the project making it suited to HPAL.

The characteristics of the Wingellina Project also provide the opportunity for the ISR approach to exploiting the deposit. This is a much lower capital path than HPAL, with lower OPEX, and the potential for zero emissions production of Ni/Co products. Moreover, the environmental footprint of an ISR operation is very much smaller than a conventional mine.

The deposit has a considerable lateral extent, is close to the surface, and has a low strip ratio, favouring lower mining costs. Based on the Ore Reserve (100% Probable Ore Reserve) containing 1.56Mt nickel and 123,600 tonnes of cobalt, the Project could support an annual production of 40,000 tpa of nickel and 3,000 tpa of cobalt for a life of approximately 40 years.

³ Mixed hydroxide precipitate (MHP) is an intermediate product of nickel metallurgy derived from laterite ores, which contains both nickel (typically 34–55% Ni content) and a small amount of cobalt (typically 1–4.5% Co content). The intermediate is produced primarily at operations that utilise high pressure acid leach (HPAL) to extract nickel and cobalt from low-grade laterite ores.



The additional resource at Claude Hills demonstrates the potential to add a significant amount of additional reserves and mine life to the Wingellina Project, with potentially significant exploration upside.

Metals X has a mining and access agreement already in place covering 18,000 km² for the development of the Project, signed in July 2010 and this agreement remains current.

The multiple final product options include nickel and cobalt sulphates for battery feedstock, with demand expected to grow due to increasing sales of electric vehicles in Europe, China, the United States, and around the world. The improved outlook for nickel and cobalt is driven by sustained interest in battery minerals, and a growing focus on environmental, social and governance.

9.3 Climate Change-Related Risks and Opportunities with Increased Global Focus on Environment, Social and Governance Factors

The effects of climate change are being felt in every continent and in the oceans. However, they are not spread uniformly across the globe (Figure 13), and different parts of the world experience impacts differently. An average warming of 1.5°C across the whole globe raises the risk of heatwaves and heavy rainfall events, amongst many other potential impacts. Limiting warming to 1.5°C rather than 2°C can help reduce these risks, but the impacts the world experiences will depend on the specific greenhouse gas emissions “pathway” taken.

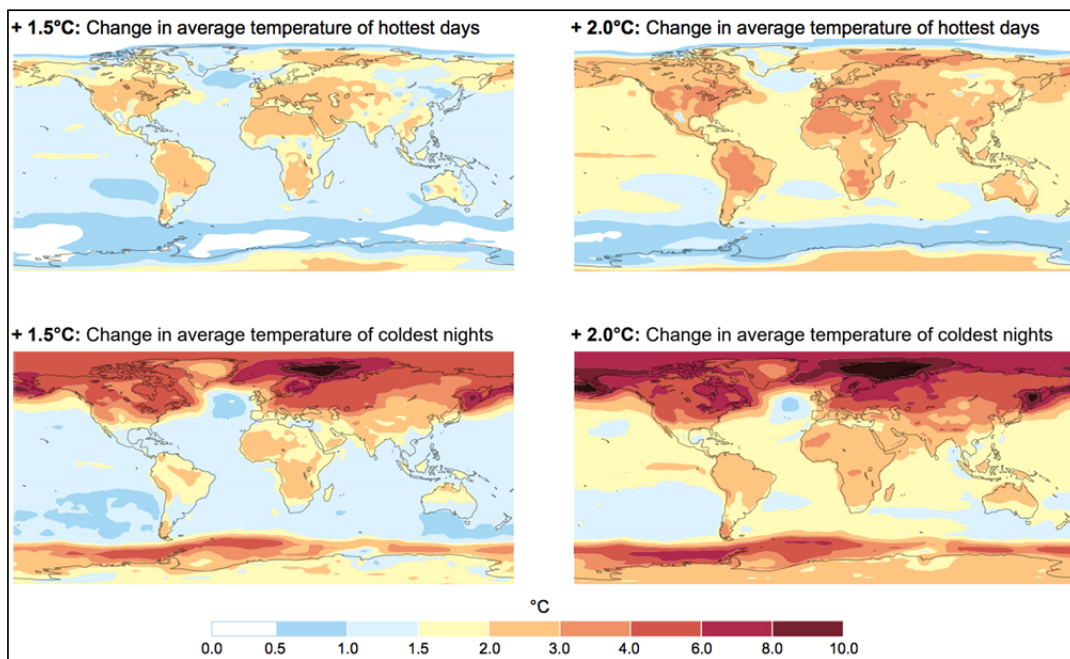

Figure 13: Impact of 1.5°C and 2.0°C global warming
 Notes: Temperature change is not uniform across the globe. Projected changes are shown for the average temperature of the annual hottest day (top) and the annual coldest night (bottom) with 1.5°C of global warming (left) and 2°C of global warming (right) compared to pre-industrial levels.
 Source: IPCC, 2018

Increasingly regulators are encouraging consideration by companies for any future potential for financial risks associated with climate change issues. The Task Force on Climate-related Financial Disclosures (TCFD) has a goal is to improve and increase reporting of climate-related financial information (TCFD, 2017). Risks associated with climate change can take the form of physical risks and transitional risks as the world economy adjusts to a low-carbon economy.

For personal use only



Physical climate change-related risks that may have an impact on exploration and mining activities include, for example:

- Extreme weather events (area dependent)
- Hot temperature extremes
- Heavy precipitation leading to flooding
- Increase in intensity or frequency of droughts
- Lower availability of water
- Increase in bushfires.

Currently, institutional investors are being pushed by their stakeholders to prioritise investment in companies that can demonstrate that they have considered and made allowances for environmental, social and governance matters that can also impact a minerals project.

A company that can demonstrate that it has attempted to address these risks, may gain an advantage in terms of more favourable rates for finance, and an increased interest from institutional investors as scrutiny in this area increases.

Additionally, being based in Australia, a jurisdiction with a good record for environmental performance, a strong regulatory framework, and a reputation for good governance, NICO is well-placed to establish itself as a preferred choice for investment.



10 Use of Funds

10.1 Use of Funds Summary

NICO provided CSA Global with a copy of its planned expenditure for the CMP for an initial two-year period following listing on the ASX (Table 10). CSA Global understands the budget in Table 10 will be scaled proportionally based on any oversubscription funds raised. All costs included are in Australian dollars (A\$).

Table 10: Proposed exploration expenditure summary by activity

Use of funds	Year 1	Year 2
Drilling and assays	\$450,700	\$854,400
Contractors, consultants and staff	\$556,100	\$532,000
Land access and compensation	\$200,400	\$192,000
Travel to site	\$200,000	\$200,000
Permits, rents and rates	\$77,100	\$76,200
Supplies and other	\$100,300	\$140,000
Feasibility studies	\$259,200	\$259,000
Directors' fees and remuneration	\$400,000	\$400,000
General administration & working capital	\$786,200	\$586,200
Capital	\$12,000	\$12,000
Future Acquisitions	\$850,000	\$500,000
Estimated Expenditure of Offer	\$928,100	0
Transfer duty	\$260,000	0
Total funds allocated	\$5,080,100	\$3,751,800

The proposed budget is considered consistent with the exploration potential of NICO's Project and plans for further development studies and is considered adequate to cover the costs of the proposed program. The budgeted expenditure is also considered sufficient to meet the minimum statutory expenditure on the tenements.

The CMP is at the "advanced exploration" stage. CSA Global considers that the Project has sound technical merit and to be sufficiently prospective, subject to varying degrees of exploration and development risk, to warrant further exploration and assessment of its economic potential, consistent with the proposed programs.

The use of funds for exploration purposes is focused primarily on:

- Infill drilling for higher confidence in mineral resource estimation and resolution of higher-grade cobalt mineralisation on the Wingellina deposit
- Infill drilling for higher confidence in Mineral Resource estimation and resolution of higher-grade cobalt-scandium mineralisation on the Claude Hills deposit
- Further exploration and deposit definition drilling in preparation for a Mineral Resource estimate of the Lewis calcrete deposit.

At least half of the liquid assets held, or funds proposed to be raised by NICO, are understood to be committed to the exploration, development, and administration of the mineral properties, satisfying the requirements of ASX Listing Rules 1.3.2(b) and 1.3.3(b). CSA Global also understands that NICO has sufficient working capital to carry out its stated objectives, satisfying the requirements of ASX Listing Rule 1.3.3(a).

NICO has prepared staged exploration and evaluation programs, specific to the potential of the CMP, which are consistent with the budget allocations, and warranted by the exploration and development potential of the Project. CSA Global considers that the relevant areas have sufficient technical merit to justify the proposed programs and associated expenditure, satisfying the requirements of ASX Listing Rule 1.3.3(a).



11 References

- Godel, B., Seat, Z., Maier, W.D., and Barnes, S.-J. 2011. *The Nebo-Babel Ni-Cu-PGE Sulfide Deposit (West Musgrave Block, Australia): Pt. 2. Constraints on Parental Magma and Processes, with Implications for Mineral Exploration*. *Economic Geology*; 106 (4): 557–584. doi: <https://doi.org/10.2113/econgeo.106.4.557>
- Grguric, B.A., Seat, Z., Hronsky, J.M.A., and Miles, G.J. 2018. *The Succoth Cu-Ni-Pd deposit: A new taxite-hosted magmatic sulphide system in the West Musgrave Province, Western Australia*. *Ore Geology Reviews*, Volume 92, Pages 397-415.
- Joint Ore Reserves Committee, 2012. *Australasian Code for Reporting of Exploration Results, Mineral Resources and Ore Reserves. The JORC Code, 2012 Edition*. [online]. Available from <http://www.jorc.org> (The Joint Ore Reserves Committee of The Australasian Institute of Mining and Metallurgy, Australian Institute of Geoscientists, and Minerals Council of Australia).
- Joly, A., Aitken, A.R.A., Dentith, M.C., Porwal, A., Smithies, R.H., and Tyler, I.M. 2014. *Mineral systems analysis of the West Musgrave Province: regional structure and prospectivity modelling*. Geological Survey of Western Australia, Report 117, 99p.
- Marsh, E., Anderson, E., and Gray, F. 2013. Nickel-cobalt laterites—A deposit model, chap. H of *Mineral deposit models for resource assessment: U.S. Geological Survey Scientific Investigations Report 2010–5070–H*, 38p.
- Metals X Limited, 2016. Nickel Division. Annual Mineral Resource Commentary. June 2016. Internal Report. 92 pp.
- Metals X Limited, 2017. Nickel Division. Annual Mineral Resource Commentary. June 2017. Internal Report. 92 pp.
- Metals X Limited, 2018a. Austral Nickel Pty Ltd Annual Technical Report Exploration Conducted on Exploration Licence: 5860 "Claude Hills" for the Period Ending 19 June 2018
- Metals X Limited, 2018b. Hinckley Range Pty Ltd Annual Report for the Period 23 December 2017 to 22 December 2018 Annual Exploration Report. WAMEX Item A119371
- Metals X Limited, 2019. Information Memorandum Central Musgrave (Wingellina) Nickel-Cobalt Project. Internal Report. 57 pp.
- Metals X Limited, 2020. Annual Report for the Period 5 June 2019 to 4 May 2020 Annual Report E69/3065. WAMEX Item A124154
- Quentin de Gromard, R., Howard, H.M., Smithies, R.H., Wingate, M.T.D., and Lu, Y. 2017. *The deep seismic reflection profile 11GA-YO1 in the west Musgrave Province: an updated view*. Geological Survey of Western Australia, Record 2017/8, 20p.
- Seat, Z., Beresford, S.W., Grguric, B.A. et al. 2007. *Architecture and emplacement of the Nebo-Babel gabbronorite-hosted magmatic Ni-Cu-PGE sulphide deposit, West Musgrave, Western Australia*. *Miner Deposita* 42, 551.
- Seat, Z., Beresford, S.W., Grguric, B.A., Gee, M.A.M., and Grassineau N.V. 2009. *Reevaluation of the Role of External Sulfur Addition in the Genesis of Ni-Cu-PGE Deposits: Evidence from the Nebo-Babel Ni-Cu-PGE Deposit, West Musgrave, Western Australia*. *Economic Geology*; 104 (4): 521–538. doi:<https://doi.org/10.2113/gsecongeo.104.4.521>
- Seat, Z., Gee, M.A.M., Grguric, B.A., Beresford, S.W., and Grassineau, N.V. 2011. *The Nebo-Babel Ni-Cu-PGE Sulfide Deposit (West Musgrave, Australia): Pt. 1. U/Pb Zircon Ages, Whole-Rock and Mineral Chemistry, and O-Sr-Nd Isotope Compositions of the Intrusion, with Constraints on Petrogenesis*. *Economic Geology*; 106 (4): 527–556. doi: <https://doi.org/10.2113/econgeo.106.4.527>
- Seubert, R.E.B. 2017. *Petrogenesis of the mafic-ultramafic intrusions of the Mesoproterozoic Giles Event, Musgrave Province, central Australia*. Geological Survey of Western Australia, Report 172, 409p.
- VALMIN, 2015, *Australasian Code for Public Reporting of Technical Assessments and Valuations of Mineral Assets (The VALMIN Code)*, 2015 edition. [online]. Available from <http://www.valmin.org> (The VALMIN Committee of The Australasian Institute of Mining and Metallurgy, and The Australian Institute of Geoscientists).
- Walsh, A. 2017. *Thermo-mechanical evolution of orogeny in the Musgrave Province*. Geological Survey of Western Australia, Report 166, 188p.



12 Glossary

For further information or for terms that are not described here, please refer to internet sources such as Wikipedia (www.wikipedia.org).

amphibolite	A metamorphic crystalline rock consisting mainly of amphiboles and some plagioclase.
amphibolite facies	The set of metamorphic mineral assemblages (facies) which is typical of regional metamorphism between 450°C and 700°C.
Archaean	Widely used term for the earliest era of geological time spanning the interval from the formation of Earth to about 2,500 million years ago.
alluvium	Loose, unconsolidated (not cemented together into a solid rock) soil or sediment that has been eroded, reshaped by water in some form, and redeposited in a non-marine setting.
anticline	A fold that is convex upward – an arch-like shape with the oldest beds at the core.
batholith	A large, generally discordant plutonic mass that has more than 40 square miles (100 km ²) of surface exposure and no known floor.
Competent Person	A minerals industry professional who is a Member or Fellow of the Australasian Institute of Mining and Metallurgy or the Australian Institute of Geoscientists, or of a Recognised Professional Organisation, as included in a list available on the JORC and ASX websites. A Competent Person must have a minimum of five years relevant experience in the style of mineralisation or type of deposit under consideration, and in the activity which that person is undertaking.
Exploration Results	Includes data and information generated by mineral exploration programs that might be of use to investors, but which do not form part of a declaration of Mineral Resources or Ore Reserves.
felsic	Pale igneous rock composed predominantly of quartz and feldspars.
Ga	Is an abbreviation used for billions (thousand million) of years ago.
gneiss	A high temperature and high pressure metamorphic rock.
HPAL	High-pressure acid leaching; a process used to extract nickel and cobalt from laterite ore bodies. The HPAL process utilizes elevated temperatures (roughly 255 degrees Celsius), elevated pressures (roughly 50 bar or 725 psi), and sulfuric acid to separate nickel and cobalt from the laterite ore. HPAL has been used since 1961 when it was first put into commercial production at Moa Bay, Cuba. It has subsequently increased in use since that time.
ISL	In situ leaching; in situ mining is a general term that includes both leaching and borehole (or slurry) mining methods. In situ leaching does not include dump or heap leaching where the ore is blasted and/or dug and placed in areas specially prepared for leaching, but is reserved for the process where chemical solutions are circulated through the ore body.
Ma	Is an abbreviation used for millions of years ago.
mafic	Dark silicate or igneous rock rich in magnesium and iron.
mineral	Any naturally occurring material found in or on the Earth's crust that is either useful to or has a value placed on it by humankind, or both. This excludes hydrocarbons, which are classified as petroleum.
Mineral Asset	All property including (but not limited to) tangible property, intellectual property, mining and exploration tenure and other rights held or acquired in connection with the exploration, development of and production from those tenures.



mineral project	Any exploration, development or production activity, including a royalty or similar interest in these activities, in respect of minerals.
mineralisation	Any single mineral or combination of minerals occurring in a mass, or deposit, of economic interest. The term is intended to cover all forms in which mineralisation might occur, whether by class of deposit, mode of occurrence, genesis or composition.
mining	All activities related to extraction of minerals by any method (e.g. quarries, open cast, open cut, solution mining, dredging etc.).
mining industry	The business of exploring for, extracting, processing and marketing minerals.
nappe	A sheet of rock that has moved sideways over neighbouring strata as a result of an overthrust or folding.
nickel	Metal commonly used in steel and lithium-ion batteries.
Phanerozoic	The geological time period we are currently in, from 541 million years ago until now.
Practitioner	An Expert as defined in the Corporations Act, who prepares a Public Report on a Technical Assessment or Valuation Report for Mineral Assets. This collective term includes Specialists and Securities Experts.
Proterozoic	A geological time period spanning the time interval from 2500 to 541 million years ago.
Public Report	A report prepared for the purpose of informing investors or potential investors and their advisers when making investment decisions, or to satisfy regulatory requirements.
Specialist Report	A report detailing a Technical Assessment and/or Valuation of Mineral Assets, prepared by a Specialist for use in an Independent Expert Report.
Specialist	Persons whose profession, reputation or relevant industry experience in a technical discipline (such as geology, mine engineering or metallurgy) provides them with the authority to assess or value Mineral Assets.
syncline	A fold in a sequence of rock layers in which the younger rock layers are found in the centre (along the axis) of the fold.
Volcanic-hosted massive sulphide	Volcanic-hosted massive sulphide deposit, generally lead, zinc ± copper deposit formed by submarine exhalative vents in sedimentary or volcanic rocks.
Technical Assessment	An evaluation prepared by a Specialist of the technical aspects of a Mineral Asset. Depending on the development status of the Mineral Asset, a Technical Assessment may include the review of geology, mining methods, metallurgical processes and recoveries, provision of infrastructure and environmental aspects.
tenure	Any form of title, right, licence, permit or lease granted by the responsible government in accordance with its mining legislation that confers on the holder certain rights to explore for and/or extract agreed minerals that may be (or is known to be) contained. Tenure can include third-party ownership of the minerals (for example, a royalty stream). Tenure and title have the same connotation as tenement.
ultramafic	Igneous rocks with very low silica and very high magnesium and iron-rich minerals.



13 Abbreviations and Units of Measurement

°	degrees
°C	degrees Celsius
A\$	Australian dollar(s)
Acclaim	Acclaim Exploration Ltd
AIG	Australian Institute of Geoscientists
Aker	Aker Solutions
Al ₂ O ₃	aluminium oxide
APY	Anangu Pitjantjatjara Yankunytjatjara
ASIC	Australian Securities and Investments Commission
ASX	Australian Securities Exchange
AusIMM	Australasian Institute of Mining and Metallurgy
Austral	Austral Nickel Pty Ltd
CMP	Central Musgrave Project
Co	cobalt
CSA Global	CSA Global Pty Ltd
CSIRO	Commonwealth Scientific and Industrial Research Organisation
DTM	digital terrain model
EPA	Environmental Protection Authority
Fe ₂ O ₃	iron(III) oxide (or ferric oxide)
ft	feet or (foot)
g	gram(s)
GSWA	Geological Survey of Western Australia
ha	hectares
HPAL	high-pressure acid leaching
INCO	International Nickel Company
IPO	initial public offering
kg	kilogram(s)
kg/t	kilograms per tonne
km, km ²	kilometres, square kilometres
kt	thousand tonnes
ktpa	thousand tonnes per annum
LME	London Metals Exchange
m, m ² , m ³	metre(s), square metre(s), cubic metre(s)
Metals X	Metals X Limited
Mg	magnesium
MHP	mixed hydroxide precipitate

NICO RESOURCES LIMITED
TECHNICAL ASSESSMENT REPORT



mm	millimetre(s)
Mn	manganese
Mt	million tonnes
Mtpa	million tonnes per annum
MW	megawatt(s)
Ni	nickel
NICO	NICO Resources Limited
NMA	Nickel Mines of Australia NL
PFS	pre-feasibility study
PGE	platinum group element(s)
posNEP	POSCO Nickel Extraction Process
ppb	parts per billion
ppm	parts per million
RAB	rotary air blast
RC	reverse circulation
RIP	resin-in-pulp
RTE	Rio Tinto Exploration
SAGS	South Australian Geological Survey
SEM	scanning electron microscopy
SGS	SGS Minerals Metallurgy
Si	silicon
SiO ²	silica
SML	Southwestern Mining Ltd
t	tonne(s)
t/m ³	tonnes per cubic metre
TCFD	Task Force on Climate-related Disclosures
tpa	tonnes per annum
TUNRA	The University of Newcastle Research Associates
US\$	United States of America dollar(s)
XRF	x-ray fluorescence



Appendix A JORC Table 1

Section 1: Sampling Techniques and Data

(Criteria in this section apply to all succeeding sections)

Criteria	Commentary
Sampling techniques, drilling techniques, and drill sample recovery	<p>Diamond drilling A small portion of the data used in resource calculations at the Central Musgrave Project (CMP) has been gathered from diamond core. This core is geologically logged before sampling.</p> <p>Reverse circulation percussion (RC) drilling RC drilling has been utilised extensively at the CMP. Drill cuttings are extracted from the RC return via cyclone. The underflow from each interval is transferred via a bucket to a four-tiered riffle splitter, delivering approximately 3 kg of the recovered material into calico bags for analysis. The residual material is retained on the ground near the hole. Composite samples are obtained from the residue material for initial analysis, with the split samples remaining with the individual residual piles until required for re-split analysis or eventual disposal.</p> <p>Historical A variety of drilling methods were employed by INCO, including churn drilling (102 holes) DDH (19 holes) RAB drilling (2,643 holes), vacuum (77 holes), and Becker drilling (102 holes). Sample recovery from early drilling by INCO is not known. Sample recovery from RC drilling carried out from RC drilling after 2001 was generally very good, except where the drillhole encountered strong water flow from the hole. All geology input is logged and validated by the relevant area geologists, incorporated into this is an assessment of sample recovery. No defined relationship exists between sample recovery and grade. Nor has sample bias due to preferential loss or gain of fine or coarse material been noted.</p>
Logging	<p>Diamond core is logged geologically and geotechnically. RC hole chips are logged geologically. Logging is quantitative in nature. All holes are logged completely.</p>
Sub-sampling techniques and sample preparation	<p>A sample of each 5 ft of drilling from INCO drilling was quartered and forwarded for assay, either to AMDEL in Adelaide, or to INCO's in-house laboratory at Blackstone. Samples of RC drilling taken before 2006 were composited on a 3 m or 4 m basis, and the composite was assayed. A 1 m riffle split sample was also taken for each metre drilled and was submitted for analysis if the composite assayed >0.4% Ni. Sub-sampling for the 2006 and later RC drilling was riffle split for each 2 m sample drilled. Chips/core chips undergo total preparation. Quality assurance/quality control (QAQC) is currently ensured during the sub-sampling stages process via the use of the systems of an independent NATA/ISO accredited laboratory contractor. A portion of the historical informing data has been processed by in-house laboratories. The sample size is considered appropriate for the grain size of the material being sampled. The un-sampled half of the diamond core is retained for check sampling if required. For RC chips regular field duplicates are collected and analysed for significant variance to primary results.</p>
Quality of assay data and laboratory tests	<p>Samples of INCO's drilling were dried and assayed by atomic absorption spectrometry (AAS) either at AMDEL in Adelaide, or at INCO's in-house laboratory at Blackstone. The digest method was not specified. Samples were assayed for nickel, cobalt, and iron. Analytical quality control was maintained by the insertion of standard samples and re-analysis of duplicates at separate laboratories at a frequency of two check analyses for every 20 samples. Composite samples of RC drilling completed in 2001 were submitted to AMDEL, dried and pulverised, and assayed for Ni, Co, Ag, As, Bi, Cu, Cr, Fe, Mg, Mn, Pb, S, Sb, Ti, V, Zr, Ca and Al by HF-multi-acid digest/inductively coupled plasma-optical emission spectroscopy (ICP-OES). The 1 m riffle-splits for any composite sample assaying >0.4% Ni were retrieved, and re-assayed using the same method. Composite samples from 2002 to 2004 were assayed for Al, Ca, Cr, Fe, Mg, Mn, Ni, Si, Ti by borate fusion ICP-OES, and for Ag, As, Bi, Co, Cu, Ni, Pb, S, Sb, V, Zr by HF-multi-acid digest/ICP-OES.</p>

NICO RESOURCES LIMITED
TECHNICAL ASSESSMENT REPORT



Criteria	Commentary
	<p>During 2005, 2 m composite riffle split (or spear-sampled for wet samples) samples were sent to SGS Laboratories in Perth. Each 2 m composite sample was dried and pulverised to a nominal 90% passing 75 microns and analysed for: As, Bi, Co, Cu, Ni, Pb, S and Zn by ICP-OES. Samples returning >0.4% Ni were re-assayed for Ni, Co, Al₂O₃, CaO, K₂O, Fe₂O₃, MgO, MnO, Na₂O, SiO₂, V₂O₅, TiO₂, Cr, SO₃, Cu, Zn by fused disc XRF.</p> <p>After 2005, 2 m composite riffle split (or spear-sampled) samples were sent to SGS Laboratories in Perth. Each sample was pulverised to nominal 90% passing 75 µm for analysis for assay for Ni, Co, Al₂O₃, SiO₂, TiO₂, Fe₂O₃, MnO, CaO, K₂O, MgO, SO₃, Na₂O, V₂O₅, Cr, Cu and Zn by fused disc XRF.</p> <p>Duplicate samples were taken by spearing the sample pile on the ground approximately every 20 samples, and an in-house standard was inserted into the sample run every alternate 20 samples.</p> <p>No significant QAQC issues have arisen in recent drilling results.</p> <p>These assay methodologies are appropriate for the resource in question.</p>
Verification of sampling and assaying	<p>Anomalous intervals, as well as random intervals, are routinely checked assayed as part of the internal QAQC process.</p> <p>Virtual twinned holes have been drilled in several instances across all sites with no significant issues highlighted.</p> <p>Primary data is loaded into the drillhole database system and then archived for reference.</p> <p>All data used in the calculation of resources and reserves are compiled in databases that are overseen and validated by senior geologists.</p> <p>No primary assays data is modified in any way.</p>
Location of data points	<p>All hole collar locations for RC holes drilled after 2000 were surveyed using a Real-Time Kinematic global positioning system (GPS). This measured X, Y and Z to sub-centimetre accuracy in terms of the MGA 94, Zone 52 metric grid.</p> <p>Hole collars for almost all INCO drillholes were relocated and surveyed using the TREK GPS. Several INCO collars could not be located, and their MGA positions are estimated from their drilled location on the original INCO Imperial local grid.</p> <p>Topographic control is generated from a combination of remote sensing methods and ground-based surveys. This methodology is adequate for the resource in question.</p>
Data spacing and distribution	<p>Drillhole spacing at CMP is generally on a 120 m x 50 m spacing. This has been infilled to 60 m x 50 m and 30 m x 25 m spacing in some areas. The data spacing is sufficient for both the estimation procedure and resource classification applied.</p> <p>Compositing of drill assay data to 2 m was used in the estimate.</p>
Orientation of data in relation to geological structure	<p>Drilling intersections are nominally designed to be sub-normal to the orebody.</p> <p>It is not considered that drilling orientation has introduced an appreciable sampling bias.</p>
Sample security	<p>Samples are delivered to a third party transport service, who in turn relay them to the independent laboratory contractor. Samples are stored securely until they leave site.</p>
Audits or reviews	<p>Site generated resources and reserves and the parent geological data is routinely reviewed by the Metals X Limited (Metals X) Corporate technical team.</p>

Section 2: Reporting of Exploration Results

(Criteria listed in the preceding section also apply to this section)

Criteria	Commentary
Mineral tenement and land tenure status	<p>The CMP comprises five granted exploration leases and one granted miscellaneous lease.</p> <p>Native title interests are recorded against the CMP tenements.</p> <p>The CMP tenements are held by Austral Nickel Pty Ltd (South Australia) and Hinckley Range Pty Ltd (Western Australia). Metals X has 100% ownership of both companies.</p> <p>One third party royalty agreement applies to the tenements at CMP, over and above the state government royalty.</p> <p>Hinckley Range Pty Ltd and Austral Nickel Pty Ltd operate in accordance with all environmental conditions set down as conditions for grant of the leases.</p> <p>There are no known issues regarding the security of tenure.</p> <p>There are no known impediments to continued operation.</p>

CSA Global Report N° R308.2021



Criteria	Commentary
Exploration done by other parties	The CMP area has an exploration history that extends back to the 1960s, with significant contributors being INCO, Acclaim Exploration Ltd (Acclaim) and Metex Nickel (now Metals X). On balance, Metals X work has generally confirmed the veracity of historical exploration data.
Geology	The Musgrave Block is an east-west trending, structurally bounded mid-Proterozoic terrane some 130,000 km ² in area, straddling the common borders of Western Australia, South Australia, and the Northern Territory. Deep weathering of olivine-rich ultramafic units has resulted in the concentration of nickel mineralisation. The olivines in the ultramafic units have background values of about 0.15% Ni to 0.3% Ni. The almost complete removal of magnesium oxide and SiO ₂ to groundwaters during the weathering of olivines in the ultramafic units resulted in extreme volume reductions and consequent significant upgrading of other rock-forming oxides (Fe ₂ O ₃ , Al ₂ O ₃) and metal element concentrations in the weathered profile.
Drillhole Information	No drillhole information is being presented as Exploration Results.
Data aggregation methods	No drillhole information is being presented as Exploration Results, a Mineral Resource estimate has been completed.
Relationship between mineralisation widths and intercept lengths	No drillhole information is being presented as Exploration Results, a Mineral Resource estimate has been completed.
Diagrams	No drillhole information is being presented as Exploration Results.
Balanced reporting	No drillhole information is being presented as Exploration Results, a Mineral Resource estimate has been completed.
Other substantive exploration data	No drillhole information is being presented as Exploration Results.
Further work	No drillhole information is being presented as Exploration Results.

Section 3: Estimation and Reporting of Mineral Resources

(Criteria listed in section 1, and where relevant in section 2, also apply to this section)

Criteria	Commentary
Database integrity	Drillhole data is stored in a MaxGeo DataShed system based on the Sequel Server platform which is currently considered "industry standard". As new data is acquired it passes through a validation approval system designed to pick up any significant errors before the information is loaded into the master database. The information is uploaded by a series of Sequel routines and is performed as required. The database contains diamond drilling (including geotechnical and specific gravity data), and some associated metadata. By its nature, this database is large in size and therefore exports from the main database are undertaken (with or without the application of spatial and various other filters) to create a database of workable size, preserve a snapshot of the database at the time of orebody modelling and interpretation and preserve the integrity of the master database.
Site visits	The site is manned continually by Senior Geological personnel. The Competent Person has undertaken site visits in the recent past.
Geological interpretation	Confidence in the geological model used to constrain the Wingellina estimate is high, with the genetic model for lateritic nickel development well understood. Logged geology has been used to drive the mineralisation interpretation, with the base of laterite defined with drillholes, or its level on a given section interpreted from surrounding drill sections. Continuity of the interpretation across and along the Wingellina deposit is for the most part good, with intersections of hard rock in drillholes, and well-mapped outcropping basement the primary causes of breaks within the mineralised horizon. No alternative interpretations are currently considered viable. Geological interpretation of the deposit was carried out using a systematic approach to ensure that the resultant estimated Mineral Resource figure was both sufficiently constrained, and representative of the expected subsurface conditions. In all aspects of resource estimation, the factual and interpreted geology was used to guide the development of the interpretation.

For personal use only

NICO RESOURCES LIMITED
TECHNICAL ASSESSMENT REPORT



Criteria	Commentary
	The protolithology is the dominant control on grade continuity at the CMP. Structural controls which influence the depth of weathering are secondary controls on grade distribution.
Dimensions	Individual deposit scales vary across the CMP. The Wingellina deposits have a strike length of >9 km, a lateral extent of up to 2.5 km and a depth of up to 200 m.
Estimation and modelling techniques	All modelling and estimation work undertaken was carried out in three dimensions via Micromine or Surpac Vision. After validating the drillhole data to be used in the estimation, interpretation of the orebody is undertaken in sectional and/or plan view to create the outline strings which form the basis of the three-dimensional (3D) orebody wireframe. Wireframing is then carried out using a combination of automated stitching algorithms and manual triangulation to create an accurate 3D representation of the subsurface mineralised body. Drillhole intersections within the mineralised body are defined, these intersections are then used to flag the appropriate sections of the drillhole database tables for compositing purposes. Drillholes are subsequently composited to allow for grade estimation. In all aspects of resource estimation the factual and interpreted geology was used to guide the development of the interpretation. Once the sample data has been composited, a statistical analysis (using Snowden Supervisor v8.5) is undertaken to assist with determining estimation search parameters, top cuts, etc. Variographic analysis of individual domains is undertaken to assist with determining appropriate search parameters. Which are then incorporated with observed geological and geometrical features to determine the most appropriate search parameters. An empty block model is then created for the area of interest. This model contains attributes set at background values for the various elements of interest as well as density, and various estimation parameters that are subsequently used to assist in resource categorisation. The block sizes used in the model will vary depending on orebody geometry, minimum mining units, estimation parameters and levels of informing data available. Grade estimation is then undertaken, with the ordinary kriging estimation method considered as standard, although in some circumstances where sample populations are small, or domains are unable to be accurately defined, inverse distance weighting estimation techniques may be used. Both by-product and deleterious elements are estimated at the time of primary grade estimation if required. It is assumed that by-products correlate well with nickel. There are no assumptions made about the recovery of by-products. The resource is then depleted for mining voids and subsequently classified in line with JORC guidelines utilising a combination of various estimation derived parameters and geological/mining knowledge. This approach has proven to be applicable to Metals X's nickel assets. Estimation results are routinely validated against primary input data, previous estimates, and mining output.
Moisture	Tonnage estimates are dry tonnes.
Cut-off parameters	The resource reporting cut-off grade is 0.5% Ni. The reporting cut-off used was based on MLX's current interpretation of commodity markets, and to allow peer group comparison.
Mining factors or assumptions	Not considered for Mineral Resources. Applied during the Reserve generation process.
Metallurgical factors or assumptions	Not considered for Mineral Resources. Applied during the Reserve generation process.
Environmental factors or assumptions	MLX stated that they operated in accordance with all environmental conditions set down as conditions for grant of the respective leases.
Bulk density	Sampling of HQ diamond drill core was used to determine the dry density of laterite ore. The average measured dry density is 1.23 t/m ³ for limonite ore and 1.40 t/m ³ saprolite ore. A total of 281 triple-tube HQ core samples were collected immediately from the core barrel and measured for bulk density on site. The core length was measured for diameter and length (square-cut ends), dried for 24 hours in a gas oven at 120°C, and weighed. Density was calculated by dividing the weight (kg) of the dry sample by the volume of the core piece.

CSA Global Report N° R308.2021



Criteria	Commentary
Classification	Resources are classified in line with JORC guidelines utilising a combination of various estimation derived parameters, the input data and geological/mining knowledge. This approach considers all relevant factors and reflects the Competent Person's view of the deposit.
Audits or reviews	Resource estimates are peer-reviewed by the site technical team as well as Metals X's Corporate technical team.
Discussion of relative accuracy/ confidence	All currently reported resource estimates are considered robust, and representative on both a global and local scale.

Section 4: Estimation and Reporting of Ore Reserves

(Criteria listed in section 1, and where relevant in sections 2 and 3, also apply to this section)

Criteria	Commentary
Mineral Resource estimate for conversion to Ore Reserves	At all projects, all resources that have been converted to reserve are classified as either an Indicated or Measured Resource. Indicated Resources are only upgraded to Probable Reserves after adding appropriate modifying factors. Some Measured Resource may be classified as Proven Reserves and some may be classified as Probable Reserves based on whether it is capitally or fully developed.
Site visits	Irregular site visits have been undertaken. The reserve has remained consistent since the 2008 Feasibility Study was completed.
Study status	A Feasibility Study utilising a combination of internal and external expertise has been undertaken to allow the conversion of Mineral Resources to Ore Reserves.
Cut-off parameters	The cut-off grade used for inclusion in the CMP Reserve was determined through the Feasibility Study process. Cobalt co-product revenue is considered by the Feasibility Study.
Mining factors or assumptions	Whittle 4D was used to formulate optimal pit shell, with subsequent designs being undertaken in Surpac. Mining studies indicate most material will be free digging, but an allowance has been made to blast some material. The material outcrops and has an overall strip ratio of 1.1:1. Due to the shallow nature and expected ground conditions, slope angles are low. Geotechnical data has been obtained through logging. The Mineral Resource was used to formulate the Ore Reserves. Due to the bulk nature of the deposit, limited dilution factors have been used, combined with high recovery factors.
Metallurgical factors or assumptions	Based on this preliminary assessment, the Wingellina deposit may be processed by a pressure acid leach flowsheet. Pressure acid leach is a proven nickel extraction method both in Australia and globally. Extensive testwork including at pilot plant scale has been conducted on CMP material over the period 1965 to 2013. Alternate processing options are actively being tested.
Environmental	Waste dumps were considered during the Feasibility Study. A draft Public Environmental Notice has been completed and will be published.
Infrastructure	Limited infrastructure is currently present. All required infrastructure was considered in the Feasibility Study. Infrastructure is considered standard for a remote site setup.
Costs	The Feasibility Study was completed in 2008 using both independent and internal cost estimates. These costs were updated in 2012. Both government and private royalties are payable. All royalties were considered as part of the Feasibility Study.
Revenue factors	The Feasibility Study progressed utilising assumptions regarding foreign exchange rates and commodity prices presented below. These prices have been set by corporate management and are considered a realistic forecast of expected commodity prices and exchange rates over the initial period of projected operation at Wingellina. <ul style="list-style-type: none"> • Ni = US\$20,000/t • Co = US\$45,000/t

For personal use only

NICO RESOURCES LIMITED
TECHNICAL ASSESSMENT REPORT



Criteria	Commentary
	<ul style="list-style-type: none"> Exchange rate (A\$:US\$) US\$0.85. Head grades have been defined via Whittle optimisation and subsequent scheduling.
Market assessment	Detailed economic studies of the nickel market and future price estimates are considered by Metals X and applied in the estimation of revenue, cut-off grade analysis and future mine planning decisions. There remains strong demand and no apparent risk to the long-term demand for the nickel generated from the CMP.
Economic	For the CMP, which is yet to be funded, an 8% real discount rate is applied to net present value analysis. Sensitivity analysis of key financial and physical parameters is applied to future development project considerations and mine.
Social	The CMP is yet to start and will require environmental and other regulatory permitting.
Other	A Native Title agreement has been reached.
Classification	<p>The basis for classification of the resource into different categories is made on a subjective basis. Measured Resources have a high-level of confidence and are generally defined in three dimensions. Indicated resources have a slightly lower level of confidence but contain substantial drilling and are well defined from a mining perspective. Inferred Resources always contain significant geological evidence of existence and are drilled, but not to the same density. There is no classification of any resource that is not drilled or defined by substantial physical sampling works.</p> <p>Some Measured Resources have been classified as Proven and some are defined as Probable Reserves based on subjective internal judgements.</p> <p>The result appropriately reflects the Competent Person's view of the deposit.</p>
Audits or reviews	Site generated reserves and the parent data and economic evaluation data is routinely reviewed by the Metals X Corporate technical team. Resources and Reserves have in the past been subjected to external expert reviews, which have ratified them with no issues. There is no regular external consultant review process in place.
Discussion of relative accuracy/confidence	<p>All currently reported reserve calculations are considered representative on a global scale. Only material considered as part of the Feasibility Study has been included as part of the reserve statement.</p> <p>Limited modifying factors have been applied due to the massive nature of the deposit and the closeness to the surface.</p>

CSA Global Report N° R308.2021

For personal use only

For personal use only



csaglobal.com



For personal use only



NICO RESOURCES

📍 Level 11, 216 St Georges Terrace
Perth Western Australia 6000

☎ +61 8 9481 0389

✉ info@nicoresources.com.au

🌐 www.nicoresources.com.au